

Project Configuration Sheet – SPV2102-nn

Peripheral Arm with *DuraTilt™* Swingarm SP2, 200mm with lockring, Cable Clip & *DuraTilt™* Version 1.5

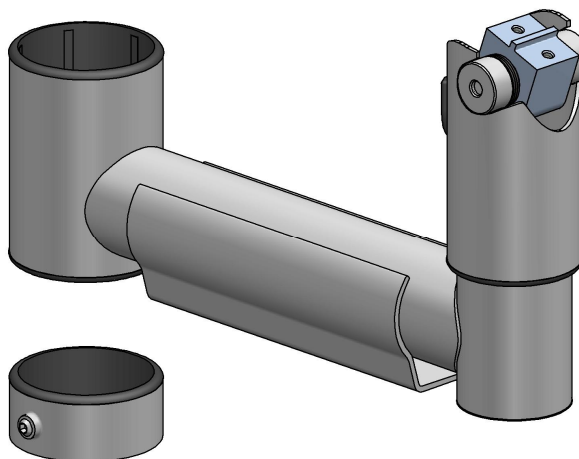

Parts List

Part No.	Description	Qty	Assemble	Box
SP2-C200084	Swingarm SP2, 200mm with 78mm Endpole and 210° Rot. slot	1	1	1
7501	<i>DuraTilt™</i> tilting joint with anti wobble sleeve (P22116), M6/6mm hex screw (M9936-0606), cable grommet (P22610) and SpacePole sticker (MK15-0007)	1	1	1
SP2-21210	Lockring SP2	1	1	1
SP2-P22700-0125	Cable Clip SP2, 125mm	1	1	1

Installation Guide MK15-0174

Box 18x packed in Master Box B007

Packaging Item Box = B007 (packed 18) Item Weight = 17kg Pallet Capacity = 90 items

Box Label MK15-0029 – SPV2102-nn – V 1.5 (place on each item)
MK15-0026 – 18x SPV2102-nn, Peripheral Arm with *DuraTilt™* – Swingarm SP2, 200mm with Lockring, Cable Clip & *DuraTilt™* - V 1.5

Colour	<nn>	01	Light Grey
		02	Black
		03	Silver
		04	Pearl
		05	Iron Grey