

# Command Reference

**MODEL :** CT-S280  
CT-S281  
CT-S300  
CT-S310  
CT-S310II  
CT-S2000  
CT-S4000  
CT-S601  
CT-S651  
CT-S801  
CT-S851  
BD2-2220  
PMU Series  
CT-P29x Series

Revision 0.15 2012/6/7

**CITIZEN SYSTEMS JAPAN CO.,LTD.**

## REVISION

Rev No.	Date	Comment
0.00	2006/09/26	Newly issued
0.01	2006/11/22	Add program sample for FS p and FS q
0.02	2007/02/26	Revised page 153,155,159,169,205-207
0.03	2007/05/21	Supported CT-S310
0.04	2007/08/29	Supported PMU2XXX
0.05	2008/10/23	Supported PMU2XXXII, CT-S281
0.06	2009/07/31	Supported CT-S281 Label, CT-S801
0.07	2009/08/04	Errors in writing are corrected
0.08	2009/10/08	Add ed MSW4 - MSW10 to CT-S280.
0.09	2009/10/31	Supported CT-S601
0.10	2010/01/07	Supported CT-S851 and CT-S651
0.11	2010/02/15	Supported CT-P29x series
0.12	2010/08/23	Supported PMU2300III PMU2xxx Type I, II and III are integrated as PMU series.
0.13	2011/02/23	Supported CT-S291 Model name description of CT-P29x series is changed accordingly.
0.14	2011/03/25	Supported CT-S310II GS1Databar is added.
0.15	2012/06/07	Changed CT-S281 GS FF command (added MSW5-6)

# TABLE OF CONTENTS

<b>TABLE OF CONTENTS.....</b>	<b>2</b>
<b>1. OUTLINE .....</b>	<b>8</b>
<b>1.1 OPERATION MODE .....</b>	<b>8</b>
<b>1.2 CHARACTER SET .....</b>	<b>8</b>
<b>1.3 CONTROL COMMANDS .....</b>	<b>8</b>
1.3.1 Control Command Details.....	8
1.3.2 How to Send Control Commands.....	8
<b>2. CONTROL COMMANDS.....</b>	<b>9</b>
<b>2.1 ESC/POS COMMAND LIST .....</b>	<b>9</b>
2.1.1 CT-S280 .....	9
2.1.2 CT-S281 .....	12
2.1.3 CT-S300 .....	15
2.1.4 CT-S310 .....	18
2.1.5 CT-S310II .....	21
2.1.6 CT-S2000 .....	25
2.1.7 CT-S4000 .....	29
2.1.8 CT-S601/651/801/851 .....	33
2.1.9 BD2-2220 .....	37
2.1.10 PMU2XXX .....	40
2.1.11 PMU2XXXII.....	43
2.1.12 PMU2300III.....	46
2.1.13 CT-P29x series.....	49
<b>2.2 COMMAND DETAILS.....</b>	<b>52</b>
2.2.1 Description of Items .....	52
2.2.2 Print Control Commands.....	53
LF .....	53
CR .....	54
FF (At selection of PAGE MODE).....	55
FF (valid only for Black mark/Label specification) .....	55
ESC FF .....	56
ESC J n.....	57
ESC d n.....	58
2.2.3 Print Character Commands .....	59
CAN.....	59
ESC SP n.....	60
ESC ! n .....	61
ESC % n.....	63
ESC & s n m [ a [ p ] s x a ] m-n+1 .....	64
ESC - n.....	66
ESC ? n .....	67

ESC E n.....	68
ESC G n .....	69
ESC M n.....	70
ESC R n.....	71
ESC V n.....	72
ESC t n.....	73
ESC { n.....	74
ESC ~ J n (Valid in CBM-270-Compatible Mode) .....	75
ESC ~ J n (Valid in CBM1000-Compatible Mode).....	76
DC3 n (Valid in CBM-270-Compatible Mode).....	77
DC3 n (Valid in CBM1000-Compatible Mode).....	79
GS ! n.....	80
GS B n.....	82
GS b n.....	83
<b>2.2.4 Print Position Commands .....</b>	<b>84</b>
HT .....	84
ESC \$ n1 n2.....	85
ESC D [n] k NULL.....	86
ESC T n.....	87
ESC W xL xH yL yH dxL dxH dyL dyH .....	88
ESC ¥ nL nH .....	90
ESC a n.....	91
GS \$ nL nH.....	92
GS L nL nH .....	93
GS W nL nH .....	94
GS ¥ nL nH .....	96
<b>2.2.5 Line Feed Span Commands .....</b>	<b>97</b>
ESC 2 .....	97
ESC 3 n.....	98
<b>2.2.6 Bit Image Commands.....</b>	<b>99</b>
ESC * m n1 n2 [d] k.....	99
GS * n1 n2 [d] n1xn2x8.....	100
GS / m.....	101
GS v 0 m xL xH yL yH d1 ... dk.....	102
<b>2.2.7 Status Commands.....</b>	<b>104</b>
DLE EOT n.....	104
ESC u n.....	124
ESC v .....	125
GS a n.....	126
GS r n.....	130
<b>2.2.8 Paper Detecting Commands .....</b>	<b>132</b>
ESC c 3 n .....	132
ESC c 4 n.....	133
<b>2.2.9 Panel Switch Commands.....</b>	<b>134</b>
ESC c 5 n .....	134
<b>2.2.10 Macro Commands.....</b>	<b>135</b>
GS : .....	135
GS ^ n1 n2 n3.....	136
<b>2.2.11 Cutter Commands.....</b>	<b>137</b>
ESC i.....	137
ESC m.....	138

<b>GSV m --- (1)</b> .....	<b>139</b>
<b>GSV m n --- (2)</b> .....	<b>139</b>
<b>2.2.12 Bar Code Commands</b> .....	<b>140</b>
<b>GS H n</b> .....	<b>140</b>
<b>GS f n</b> .....	<b>141</b>
<b>GS h n</b> .....	<b>142</b>
<b>(1)GS k m [d1...dk] NUL</b> .....	<b>143</b>
<b>(2)GS k m n [d1...dn]</b> .....	<b>143</b>
<b>GS w n</b> .....	<b>149</b>
<b>2.2.13 Commands for Non-volatile Memory</b> .....	<b>150</b>
<b>GS ( C pL pH m fn b [c1 c2] [d1...dk]</b> .....	<b>150</b>
fn=0, 48: Function 0 Erasing Specified Record.....	151
fn=1, 49: Function 1 Storing Data to Specified Record.....	151
fn=2, 50: Function 2 Sending Data Stored in Specified Record .....	152
fn=3, 51: Function 3 Sending Use Amount.....	153
fn=4, 52: Function 4 Sending Remaining Capacity.....	153
fn=5, 53: Function 5 Sending Key Code List of Stored Record .....	154
fn=6, 54: Function 6 Erasing All User NV Memory Area in a Lump .....	155
<b>GS ( L pL pH m fn [parameter]</b> .....	<b>156</b>
<b>GS 8 L p1 p2 p3 p4 m fn [parameter]</b> .....	<b>156</b>
fn=0, 48: Function 48 Sending NV Graphics Memory Capacity .....	157
fn=2, 50: Function 50 Printing Graphics Data Stored in Print Buffer .....	157
fn=3, 51: Function 51 Sending the Remaining Amount of NV Graphics Memory.....	158
fn=64: Function 64 Sending Key Code List of Defined NV Graphics.....	159
fn=65: Function 65 Erasing All Data of NV Graphics in a Lump .....	160
fn=66: Function 66 Erasing Specified NV Graphics Data .....	160
fn=67: Function 67 Defining Raster Type Graphics Data to NV Memory.....	161
fn=69: Function 69 Printing Specified Graphics.....	162
fn=112: Function 112 Storing Raster Type Graphics Data to Print Buffer .....	163
<b>GS g 0 m nL nH</b> .....	<b>164</b>
<b>GS g 2 m nL nH</b> .....	<b>165</b>
<b>FS p n m</b> .....	<b>166</b>
<b>FS q n [xL xH yL yH d1...dk] 1... [xL xH yL yH d1...dk] n</b> .....	<b>167</b>
<b>2.2.14 Kanji Control Commands</b> .....	<b>169</b>
<b>FS ! n</b> .....	<b>169</b>
<b>FS &amp;</b> .....	<b>170</b>
<b>FS - n</b> .....	<b>171</b>
<b>FS .</b> .....	<b>172</b>
<b>FS 2 a1 a2 [d] k</b> .....	<b>173</b>
<b>FS C n</b> .....	<b>175</b>
<b>FS S n1 n2</b> .....	<b>177</b>
<b>FS W n</b> .....	<b>178</b>
<b>FS ( A pL pH fn [...]</b> .....	<b>179</b>
fn=48: Function 48 Set Kanji fonts.....	179
<b>2.2.15 Black Mark Control Commands</b> .....	<b>180</b>
<b>GS FF</b> .....	<b>180</b>
<b>GS &lt;</b> .....	<b>181</b>
<b>GSA m n</b> .....	<b>182</b>
<b>GSC 0 m n</b> .....	<b>183</b>
<b>GSC 1 n1 n2 n3 n4 n5 n6</b> .....	<b>184</b>
<b>GSC 2 n1 n2</b> .....	<b>185</b>

<b>GS C ; n1 ; n2 ; n3 ; n4 ; n5 ;</b> .....	<b>186</b>
<b>GS c</b> .....	<b>187</b>
<b>GS l n1L n1H n2L n2H</b> .....	<b>188</b>
<b>GS p n</b> .....	<b>189</b>
<b>FS FF</b> .....	<b>190</b>
<b>2.2.16 Printer Function Setting Commands</b> .....	<b>191</b>
<b>GS ( D pL pH m [a1 b1] ... [ak bk]</b> .....	<b>191</b>
<b>GS ( E pL pH fn [...]</b> .....	<b>192</b>
fn=1: Function 1 Transferring to Printer Function Setting Mode .....	193
fn=2: Function 2 End of Printer Function Setting Mode.....	193
fn=3: Function 3 Setting Memory Switch Value.....	194
fn=4: Function 4 Sending the Set Memory Switch Value.....	219
fn=5: Function 5 Setting Customized Value .....	220
fn=6: Function 6 Sending the Set Customized Value .....	258
fn=8: Function 8 Defining Data by the Column Format to Character Code Page of Work Area .....	296
fn=9: Function 9 Defining Data in the Raster Format to the Character Code Page of Work Area .....	297
fn=10: Function 10 Erasing Data of Character Code Page Data in Work Area.....	298
fn=11: Function 11 Setting Communication Conditions .....	299
fn=12: Function 12 Sending the Set Communication Conditions .....	300
fn=255: Function 255 Setting All Contents Set by Printer Function Setting Mode to the State at Shipment.....	301
<b>GS ( K pL pH fn m</b> .....	<b>302</b>
fn=49: Function 49 Setting Printing Density .....	303
fn=50: Function 50 Setting Printing Speed .....	304
fn=97: Function 97 Setting Number of Divisions for Head Conducting .....	305
<b>GS ( M pL pH fn m</b> .....	<b>306</b>
fn=1, 49: Function 1 Copies the set value stored in work area to the storage area .....	307
fn=2, 50: Function 2 Copies the set value stored in storage area to the work area .....	307
fn=3, 51: Function 3 Specifies the auto loading function of the set value at initialization to be valid or invalid.....	308
<b>GS ( N pL pH fn m</b> .....	<b>309</b>
fn=48: Function 48 Selects character color.....	309
<b>2.2.17 2-dimensional code Commands</b> .....	<b>310</b>
<b>GS ( k pL pH cn fn [parameter]</b> .....	<b>310</b>
fn=65: Function 65 Setting the number of digits of PDF417 .....	312
fn=66: Function 66 Setting the number of steps of PDF417 .....	312
fn=67: Function 67 Setting module width of PDF417 .....	313
fn=68: Function 68 Setting the height of step of PDF417 .....	313
fn=69: Function 69 Setting error correction level of PDF417 .....	314
fn=70: Function 70 Setting Options for PDF417 .....	315
fn=80: Function 80 Storing received data to 2D code data storage area .....	315
fn=81: Function 81 Printing 2D code data in 2D code data storage area .....	316
fn=82: Function 82 Sending the size of 2D code data in 2D code data storage area .....	317
fn=65: Function 165 Specifying QRCode model .....	318
fn=67: Function 167 Sets the module width of QRCode.....	318
fn=69: Function 169 Setting QRCode error correction level.....	319
fn=80: Function 180 Storing received data to 2D code data storage area .....	319
fn=81: Function 181 Printing 2D code data in 2D code data storage area.....	320
fn=82: Function 182 Sending the size of 2D code data in 2D code data storage area.....	321
fn=67: Function 367 Setting module width of 2D GS1 DataBar .....	322
fn=71: Function 371 Setting maximum width of 2D GS1 DataBar Expanded Stacked .....	322
fn=80: Function 380 Storing 2D GS1 DataBar data to 2D code data storage area.....	323
fn=81: Function 381 Printing 2D GS1 Databar data in 2D code data storage area.....	323

fn=82: Function 382 Sending the size of 2D code data in 2D code data storage area .....	324
<b>2.2.18 Presenter/Bezel Control Commands (PMU2xxxIII only) .....</b>	<b>325</b>
GSR 0 .....	325
GSR 1 .....	325
GSR 2 n t1 t2 .....	326
GSS .....	327
<b>2.2.19 Other Commands .....</b>	<b>328</b>
DLE ENQ n .....	328
DLE DC4 fn m t (Specification of fn = 1) .....	329
DLE DC4 fn d1...d7 (Specification of fn = 8) .....	330
ESC = n .....	331
ESC @ .....	332
ESC L .....	333
ESC S .....	334
ESC p m n1 n2 .....	335
GS ( A p L p H n m .....	336
GS I n .....	337
GSP x y .....	348
ESC RS .....	349
<b>3. CHARACTER CODE TABLE .....</b>	<b>350</b>
<b>3.1 CODE PAGE .....</b>	<b>350</b>
3.1.1 Codepage 00H to 7FH & PC437 (USA, Europe Standard) .....	350
3.1.2 Codepage 00H to 7FH & Katakana .....	351
3.1.3 Codepage 00H to 7FH & PC850 (Multilingual) .....	352
3.1.4 Codepage 00H to 7FH & PC860 (Portuguese) .....	353
3.1.5 Codepage 00H to 7FH & PC863 (Canadian-French) .....	354
3.1.6 Codepage 00H to 7FH & PC865 (Nordic) .....	355
3.1.7 Codepage 00H to 7FH & PC852 (Eastern Europe) .....	356
3.1.8 Codepage 00H to 7FH & PC866 (Russian) .....	357
3.1.9 Codepage 00H to 7FH & PC857 (Turkish) .....	358
3.1.10 Codepage 00H to 7FH & PC864 (Arabic) .....	359
3.1.11 Codepage 00H to 7FH & Windows Codepage .....	360
3.1.12 Codepage 00H to 7FH & Thai code 18 .....	361
<b>3.2 INTERNATIONAL CHARACTER CODE TABLE .....</b>	<b>362</b>
<b>3.3 KANJI CODE TABLE .....</b>	<b>363</b>
3.3.1 JIS non-Kanji .....	363
3.3.2 JIS Kanji Level 1 .....	365
3.3.3 JIS Kanji Level 2 .....	371
<b>4. MEMORY SWITCH .....</b>	<b>378</b>
<b>4.1 MEMORY SWITCHES .....</b>	<b>378</b>
4.1.1 CT-S280 .....	378
4.1.2 CT-S281 .....	380
4.1.3 CT-S300 .....	382
4.1.4 CT-S310 .....	383
4.1.5 CT-S310II .....	385

4.1.6 CT-S2000 .....	387
4.1.7 CT-S4000 .....	389
4.1.8 CT-S801/851 .....	391
4.1.9 CT-S601/651 .....	393
4.1.10 BD2-2220 .....	395
4.1.11 PMU2XXX .....	396
4.1.12 PMU2XXXII .....	398
4.1.13 PMU2300III .....	400
4.1.14 CT-P29x series .....	403
<b>4.2 DETAILS OF MEMORY SWITCHES.....</b>	<b>405</b>
4.2.1 MSW1 .....	405
4.2.2 MSW2 .....	408
4.2.3 MSW3 .....	411
4.2.4 MSW4 .....	414
4.2.5 MSW5 .....	419
4.2.6 MSW6 .....	422
4.2.7 MSW7 .....	423
4.2.8 MSW8 .....	425
4.2.9 MSW9 .....	427
4.2.10 MSW10 .....	429
4.2.11 MSW11 .....	431
4.2.12 MSW12 .....	433
<b>5. APPENDIX.....</b>	<b>435</b>
5.1 EXPLANATION ON PAGE MODE .....	435
5.1.1 Overview .....	435
5.1.2 Values Set by Each Command in STANDARD MODE and PAGE MODE .....	435
5.1.3 Mapping of Print Data in the Print Area .....	436
5.1.4 Example of Using PAGE MODE .....	438
5.2 BIDIRECTIONAL PARALLEL INTERFACE.....	442
5.2.1 Parallel Interface Communication Mode .....	442
5.2.2 Interfacing Phases .....	443
5.2.3 Negotiation .....	444
5.3 IDENTIFICATION OF SEND STATUS .....	451
5.4 CAUTIONS ON BLACK MARK/LABEL PAPER.....	452



# 1. OUTLINE

## 1.1 Operation Mode

Our printer has ESC/POSTM as control commands.

## 1.2 Character Set

All print data sent from the host computer to the printer are automatically converted to one-byte alphanumeric or katakana characters (ANK) or two-byte Kanji corresponding to the characters and symbols.

**NOTE:** For the contents of character set, refer to Character Code Table of this document.

## 1.3 Control Commands

### 1.3.1 Control Command Details

Control Commands are used for controlling the operations of the printer such as starting/stopping of printing, line feeding, paper feeding, etc. They control all functions related to printing, such as type of characters, enlargement of characters or setting of format.

### 1.3.2 How to Send Control Commands

Some methods are available for sending Control Commands from the host computer to the printer. Here, a method of sending by BASIC programming is explained.

#### Example 1

Let's print a character string "CITIZEN" in enlarged (double-height, double-width) and in normal format.

#### Program coding

The Control Command shows that the command name for setting the size of a character is GS !. Let's make a program using this code. An example is shown below.

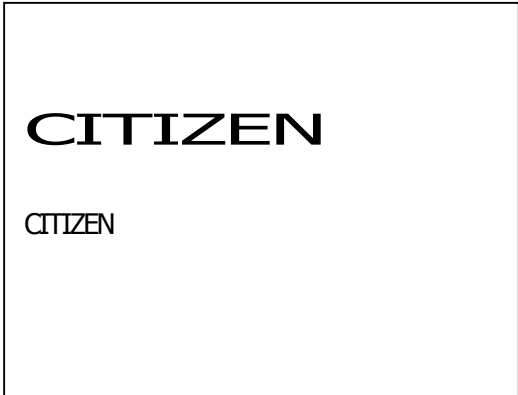
Program List	Print Result
	<pre>10 A\$="CITIZEN" 20 LPRINT CHR\$(&amp;H1D);"!"; CHR\$(&amp;H11); 30 LPRINT A\$; 40 LPRINT CHR\$(&amp;HA); CHR\$(&amp;HA); 50 LPRINT CHR\$(&amp;H1D);"!"; CHR\$(&amp;H00); 60 LPRINT A\$; 70 END</pre>

In lines 20 and 50, setting and canceling of enlarging a character is sent. As a result, lines 30 and 60 print the same character string but line 30 prints enlarged characters and line 60 cancels the enlargement and prints in normal format.

\* In this document, sample programs are in BASIC. For details of BASIC programming, refer to the manual for BASIC.

## 2. CONTROL COMMANDS

### 2.1 ESC/POS Command List

#### 2.1.1 CT-S280

##### Print Control Commands

Commands	Function	MODE	GS P	Page
<a href="#">LF</a>	Printing and paper feed	S·P		53
<a href="#">CR</a>	Back to printing	S·P		54
<a href="#">FF</a>	Printing in PAGE MODE and returning to STANDARD MODE (at the selection of PAGE MODE)	P		55
<a href="#">ESC FF</a>	Printing data in PAGE MODE	P		56
<a href="#">ESC J</a>	Printing and feeding paper in minimum pitch	S·P	○	57
<a href="#">ESC d</a>	Printing and feeding the paper by "n" lines	S·P		58

##### Print Character Commands

Command	Function	MODE	GS P	Page
<a href="#">CAN</a>	Canceling print data in PAGE MODE	P		59
<a href="#">ESC SP</a>	Setting the right spacing of the character	S·P	○	60
<a href="#">ESC !</a>	Collectively specifying the printing mode	S·P		61
<a href="#">ESC %</a>	Specifying/Canceling download character set	S·P		63
<a href="#">ESC &amp;</a>	Defining the download characters	S·P		64
<a href="#">ESC -</a>	Specifying/canceling underline	S·P		66
<a href="#">ESC ?</a>	Deleting download characters	S·P		67
<a href="#">ESC E</a>	Specifying/canceling emphasis printing	S·P		68
<a href="#">ESC G</a>	Specifying/canceling double strike printing	S·P		69
<a href="#">ESC M</a>	Selection of character fonts	S·P		70
<a href="#">ESC R</a>	Selecting the international character set	S·P		71
<a href="#">ESC V</a>	Specifying/canceling 90°-right-turned characters	S		72
<a href="#">ESC t</a>	Selecting the character code table	S·P		73
<a href="#">ESC {</a>	Specifying/canceling the inverted characters	S		74
<a href="#">ESC ~ J</a>	Specifies/cancels printing in red (black-based paper)	S·P		75
<a href="#">DC3</a>	Specifies/cancels printing in red (black-based paper)	S		77
<a href="#">GS !</a>	Specifying the character size	S·P		80
<a href="#">GS B</a>	Specifying/canceling the black/white inverted printing	S·P		82
<a href="#">GS b</a>	Specifying/canceling the smoothing	S·P		83

### Print Position Commands

Command	Function	MODE	GS P	Page
<a href="#">HT</a>	Horizontal tab	S·P		84
<a href="#">ESC \$</a>	Specifying the absolute positions	S·P	○	85
<a href="#">ESC D</a>	Setting horizontal tab position	S·P		86
<a href="#">ESC T</a>	Selecting the character printing direction in PAGE MODE	P		87
<a href="#">ESC W</a>	Defining the print area in PAGE MODE	P	○	88
<a href="#">ESC \</a>	Specifying the relative position	S·P	○	90
<a href="#">ESC a</a>	Aligning the characters	S		91
<a href="#">GS \$</a>	Specifying the absolute vertical position of characters in PAGE MODE	P	○	92
<a href="#">GS L</a>	Setting the left margin	S	○	93
<a href="#">GS W</a>	Setting the print area width	S·P	○	94
<a href="#">GS \</a>	Specifying the relative vertical position of a character in PAGE MODE	S·P	○	96

### Line Feed Span Commands

Command	Function	MODE	GS P	Page
<a href="#">ESC 2</a>	Specifying initial line feed rate	S·P		97
<a href="#">ESC 3</a>	Setting line feed rate of minimum pitch	S·P	○	98

### Bit Image Commands

Command	Function	MODE	GS P	Page
<a href="#">ESC *</a>	Specifying the bit image mode	S·P		99
<a href="#">GS *</a>	Defining the download bit image	S·P		100
<a href="#">GS /</a>	Printing the downloaded bit image	S·P		101
<a href="#">GS v 0</a>	Printing of raster bit image	S		102

### Status Commands

Command	Function	MODE	GS P	Page
<a href="#">DLE EOT</a>	Sending status in real-time	S·P		104
<a href="#">ESC v</a>	Sending Printer status	S·P		125
<a href="#">GS a</a>	Enabling/disabling ASB (Automatic Status Back)	S·P		126
<a href="#">GS r</a>	Sending status	S·P		130

### Paper Detecting Commands

Command	Function	MODE	GS P	Page
<a href="#">ESC c 3</a>	Selecting the Paper Sensor valid for Paper-end signal output	S·P		132
<a href="#">ESC c 4</a>	Selecting the Paper Near-end Sensor valid for print stop	S·P		133

### Panel Switch Commands

Command	Function	MODE	GS P	Page
<a href="#">ESC c 5</a>	Enabling/disabling the panel switches	S·P		134

### Macro Commands

Command	Function	MODE	GS P	Page
<a href="#">GS :</a>	Starting/ending macro definition	S·P		135
<a href="#">GS ^</a>	Executing the macro	S·P		136

## Bar Code Commands

Command	Function	MODE	GS P	Page
<a href="#">GS H</a>	Selecting of printing position of HRI characters	S·P		140
<a href="#">GS f</a>	Selecting the font of HRI characters	S·P		141
<a href="#">GS h</a>	Specifying the height of the bar code	S·P		142
<a href="#">GS k</a>	Printing the bar code	S·P		143
<a href="#">GS w</a>	Specifying the horizontal size (magnification) of bar code	S·P		149

## Commands for Non-volatile Memory

Command	Function	MODE	GS P	Page
<a href="#">FS p</a>	Printing the download NV bit images	S		166
<a href="#">FS q</a>	Defining the download NV bit image	S		167

## Kanji Control Commands

Command	Function	MODE	GS P	Page
<a href="#">FS !</a>	Collectively setting Kanji print mode	S·P		169
<a href="#">FS &amp;</a>	Setting Kanji mode	S·P		170
<a href="#">FS -</a>	Setting/Canceling Kanji underline	S·P		171
<a href="#">FS .</a>	Canceling Kanji mode	S·P		172
<a href="#">FS 2</a>	Defining external character	S·P		173
<a href="#">FS C</a>	Selecting Kanji code system	S·P		175
<a href="#">FS S</a>	Setting Kanji space amount	S·P	○	177
<a href="#">FS W</a>	Setting/Canceling four times enlargement of Kanji	S·P		178
<a href="#">FS ( A</a>	Setting font attribute of Kanji	S·P		179

## Printer Function Setting Commands

Command	Function	MODE	GS P	Page
<a href="#">GS ( E</a>	Printer function setting command	S		191
<a href="#">GS ( K</a>	Selecting print control method	S		302
<a href="#">GS ( M</a>	Customizing the printer	S		306
<a href="#">GS ( N</a>	Designating font attribute	S		309

## Other Commands

Command	Function	MODE	GS P	Page
<a href="#">DLE ENQ</a>	Real-time request to printer	S·P		328
<a href="#">DLE DC4</a>	Buffer clear	S·P		330
<a href="#">ESC =</a>	Data input control	S·P		331
<a href="#">ESC @</a>	Initializing the printer	S·P		332
<a href="#">ESC L</a>	Selecting PAGE MODE	S		333
<a href="#">ESC S</a>	Selecting STANDARD MODE	P		334
<a href="#">GS ( A</a>	Execution of test printing	S		336
<a href="#">GS I</a>	Sending the printer ID	S·P		337
<a href="#">GS P</a>	Specifying the basic calculation pitch	S·P		348

In the Mode column: S = STANDARD MODE, P = PAGE MODE  
 O = shows the command affected by GS P.

## 2.1.2 CT-S281

### Print Control Commands

Commands	Function	MODE	GSP	Page
<a href="#">LF</a>	Printing and paper feed	S·P		53
<a href="#">CR</a>	Back to printing	S·P		54
<a href="#">FF</a>	(1)Printing in PAGE MODE and returning to STANDARD MODE (at the selection of PAGE MODE) (2)Printing of Black mark and paper feeding to the top of the print position (with Black mark/Label paper selected)	P		55
<a href="#">ESC FF</a>	Printing data in PAGE MODE	P		56
<a href="#">ESC J</a>	Printing and feeding paper in minimum pitch	S·P	○	57
<a href="#">ESC d</a>	Printing and feeding the paper by "n" lines	S·P		58

### Print Character Commands

Command	Function	MODE	GSP	Page
<a href="#">CAN</a>	Canceling print data in PAGE MODE	P		59
<a href="#">ESC SP</a>	Setting the right spacing of the character	S·P	○	60
<a href="#">ESC !</a>	Collectively specifying the printing mode	S·P		61
<a href="#">ESC %</a>	Specifying/Canceling download character set	S·P		63
<a href="#">ESC &amp;</a>	Defining the download characters	S·P		64
<a href="#">ESC -</a>	Specifying/canceling underline	S·P		66
<a href="#">ESC ?</a>	Deleting download characters	S·P		67
<a href="#">ESC E</a>	Specifying/canceling emphasis printing	S·P		68
<a href="#">ESC G</a>	Specifying/canceling double strike printing	S·P		69
<a href="#">ESC M</a>	Selection of character fonts	S·P		70
<a href="#">ESC R</a>	Selecting the international character set	S·P		71
<a href="#">ESC V</a>	Specifying/canceling 90°-right-turned characters	S		72
<a href="#">ESC t</a>	Selecting the character code table	S·P		73
<a href="#">ESC {</a>	Specifying/canceling the inverted characters	S		74
<a href="#">ESC ~ J</a>	Specifies/cancels printing in red (black-based paper)	S·P		75
<a href="#">DC3</a>	Specifies/cancels printing in red (black-based paper)	S		77
<a href="#">GS !</a>	Specifying the character size	S·P		80
<a href="#">GS B</a>	Specifying/canceling the black/white inverted printing	S·P		82
<a href="#">GS b</a>	Specifying/canceling the smoothing	S·P		83

### Print Position Commands

Command	Function	MODE	GSP	Page
<a href="#">HT</a>	Horizontal tab	S·P		84
<a href="#">ESC \$</a>	Specifying the absolute positions	S·P	○	85
<a href="#">ESC D</a>	Setting horizontal tab position	S·P		86
<a href="#">ESC T</a>	Selecting the character printing direction in PAGE MODE	P		87
<a href="#">ESC W</a>	Defining the print area in PAGE MODE	P	○	88
<a href="#">ESC \</a>	Specifying the relative position	S·P	○	90
<a href="#">ESC a</a>	Aligning the characters	S		91
<a href="#">GS \$</a>	Specifying the absolute vertical position of characters in PAGE MODE	P	○	92
<a href="#">GS L</a>	Setting the left margin	S	○	93
<a href="#">GS W</a>	Setting the print area width	S·P	○	94
<a href="#">GS \</a>	Specifying the relative vertical position of a character in PAGE MODE	S·P	○	96

## Line Feed Span Commands

Command	Function	MODE	GS P	Page
<a href="#">ESC 2</a>	Specifying initial line feed rate	S·P		97
<a href="#">ESC 3</a>	Setting line feed rate of minimum pitch	S·P	○	98

## Bit Image Commands

Command	Function	MODE	GS P	Page
<a href="#">ESC *</a>	Specifying the bit image mode	S·P		99
<a href="#">GS *</a>	Defining the download bit image	S·P		100
<a href="#">GS /</a>	Printing the downloaded bit image	S·P		101
<a href="#">GS v 0</a>	Printing of raster bit image	S		102

## Status Commands

Command	Function	MODE	GS P	Page
<a href="#">DLE EOT</a>	Sending status in real-time	S·P		104
<a href="#">ESC v</a>	Sending Printer status	S·P		125
<a href="#">GS a</a>	Enabling/disabling ASB (Automatic Status Back)	S·P		126
<a href="#">GS r</a>	Sending status	S·P		130

## Paper Detecting Commands

Command	Function	MODE	GS P	Page
<a href="#">ESC c 4</a>	Selecting the Paper Near-end Sensor valid for print stop	S·P		133

## Panel Switch Commands

Command	Function	MODE	GS P	Page
<a href="#">ESC c 5</a>	Enabling/disabling the panel switches	S·P		134

## Macro Commands

Command	Function	MODE	GS P	Page
<a href="#">GS :</a>	Starting/ending macro definition	S·P		135
<a href="#">GS ^</a>	Executing the macro	S·P		136

## Cutter Commands

Command	Function	MODE	GS P	Page
<a href="#">ESC i</a>	Full cut	S·P		137
<a href="#">ESC m</a>	Partial cut	S·P		138
<a href="#">GS V</a>	Cutting the paper	S·P	○	139

## Bar Code Commands

Command	Function	MODE	GS P	Page
<a href="#">GS H</a>	Selecting of printing position of HRI characters	S·P		140
<a href="#">GS f</a>	Selecting the font of HRI characters	S·P		141
<a href="#">GS h</a>	Specifying the height of the bar code	S·P		142
<a href="#">GS k</a>	Printing the bar code	S·P		143
<a href="#">GS w</a>	Specifying the horizontal size (magnification) of bar code	S·P		149

## Commands for Non-volatile Memory

Command	Function	MODE	GS P	Page
<a href="#">FS p</a>	Printing the download NV bit images	S		166
<a href="#">FS q</a>	Defining the download NV bit image	S		167

## Kanji Control Commands

Command	Function	MODE	GS P	Page
<a href="#">FS !</a>	Collectively setting Kanji print mode	S·P		169
<a href="#">FS &amp;</a>	Setting Kanji mode	S·P		170
<a href="#">FS -</a>	Setting/Canceling Kanji underline	S·P		171
<a href="#">FS _</a>	Canceling Kanji mode	S·P		172
<a href="#">FS 2</a>	Defining external character	S·P		173
<a href="#">FS C</a>	Selecting Kanji code system	S·P		175
<a href="#">FS S</a>	Setting Kanji space amount	S·P	○	177
<a href="#">FS W</a>	Setting/Canceling four times enlargement of Kanji	S·P		178
<a href="#">FS ( A</a>	Setting font attribute of Kanji	S·P		179

### Black Mark and Label Control Commands

Command	Function	MODE	GS P	Page
<a href="#">GS FF</a>	Printing and ejecting Black mark paper/Label Paper	S·P		180
<a href="#">GS &lt;</a>	Initializing the printer mechanism	S·P		181
<a href="#">GS A</a>	Correcting the leader position of Black mark paper	S·P		182
<a href="#">GS C 0</a>	Setting the numbering print mode	S·P		183
<a href="#">GS C 1</a>	Setting the numbering counter mode (A)	S·P		184
<a href="#">GS C 2</a>	Setting the numbering counter	S·P		185
<a href="#">GS C ;</a>	Setting the numbering counter mode (B)	S·P		186
<a href="#">GS c</a>	Print the counter	S·P		187
<a href="#">GS l</a>	Setting the Black mark length	S·P		188

### Printer Function Setting Commands

Command	Function	MODE	GS P	Page
<a href="#">GS ( D</a>	Enabling or disabling real-time command	S		191
<a href="#">GS ( E</a>	Printer function setting command	S		191
<a href="#">GS ( K</a>	Selecting print control method	S		302
<a href="#">GS ( M</a>	Customizing the printer	S		306
<a href="#">GS ( N</a>	Designating font attribute	S		309

### 2-dimensional Code Commands

Command	Function	MODE	GS P	Page
<a href="#">GS ( k</a>	Setting and printing 2-dimensional code	S·P		310

### Other Commands

Command	Function	MODE	GS P	Page
<a href="#">DLE ENQ</a>	Real-time request to printer	S·P		328
<a href="#">DLE DC4</a>	Buffer clear	S·P		330
<a href="#">ESC =</a>	Data input control	S·P		331
<a href="#">ESC @</a>	Initializing the printer	S·P		332
<a href="#">ESC L</a>	Selecting PAGE MODE	S		333
<a href="#">ESC S</a>	Selecting STANDARD MODE	P		334
<a href="#">GS ( A</a>	Execution of test printing	S		336
<a href="#">GS I</a>	Sending the printer ID	S·P		337
<a href="#">GS P</a>	Specifying the basic calculation pitch	S·P		348

In the Mode column: S = STANDARD MODE, P = PAGE MODE  
 O = shows the command affected by GS P.

## 2.1.3 CT-S300

### Print Control Commands

Command	Function	MODE	GS P	Page
<a href="#">LF</a>	Printing and paper feed	S-P		53
<a href="#">CR</a>	Back to printing	S-P		54
<a href="#">FF</a>	(1)Printing in PAGE MODE and returning to STANDARD MODE (at the selection of PAGE MODE) (2)Printing of Black mark/Label paper and feeding paper to the top of the print position (with Black mark/Label paper selected)	P		55
<a href="#">ESC FF</a>	Printing data in PAGE MODE	P		56
<a href="#">ESC J</a>	Printing and feeding paper in minimum pitch	S-P	○	57
<a href="#">ESC d</a>	Printing and feeding the paper by "n" lines	S-P		58

### Print Character Commands

Command	Function	MODE	GS P	Page
<a href="#">CAN</a>	Canceling print data in PAGE MODE	P		59
<a href="#">ESC SP</a>	Setting the right spacing of the character	S-P	○	60
<a href="#">ESC !</a>	Collectively specifying the printing mode	S-P		61
<a href="#">ESC %</a>	Specifying/Canceling download character set	S-P		63
<a href="#">ESC &amp;</a>	Defining the download characters	S-P		64
<a href="#">ESC -</a>	Specifying/canceling underline	S-P		66
<a href="#">ESC ?</a>	Deleting download characters	S-P		67
<a href="#">ESC E</a>	Specifying/canceling emphasis printing	S-P		68
<a href="#">ESC G</a>	Specifying/canceling double strike printing	S-P		69
<a href="#">ESC M</a>	Selection of character fonts	S-P		70
<a href="#">ESC R</a>	Selecting the international character set	S-P		71
<a href="#">ESC V</a>	Specifying/canceling 90°-right-turned characters	S		72
<a href="#">ESC t</a>	Selecting the character code table	S-P		73
<a href="#">ESC {</a>	Specifying/canceling the inverted characters	S		74
<a href="#">ESC ~ J</a>	Specifies/cancels printing in red (black-based paper)	S-P		76
<a href="#">DC3</a>	Specifies/cancels printing in red (black-based paper)	S		79
<a href="#">GS !</a>	Specifying the character size	S-P		80
<a href="#">GS B</a>	Specifying/canceling the black/white inverted printing	S-P		82
<a href="#">GS b</a>	Specifying/canceling the smoothing	S-P		83

### Print Position Commands

Command	Function	MODE	GS P	Page
<a href="#">HT</a>	Horizontal tab	S-P		84
<a href="#">ESC \$</a>	Specifying the absolute positions	S-P	○	85
<a href="#">ESC D</a>	Setting horizontal tab position	S-P		86
<a href="#">ESC T</a>	Selecting the character printing direction in PAGE MODE	P		87
<a href="#">ESC W</a>	Defining the print area in PAGE MODE	P	○	88
<a href="#">ESC \</a>	Specifying the relative position	S-P	○	90
<a href="#">ESC a</a>	Aligning the characters	S		91
<a href="#">GS \$</a>	Specifying the absolute vertical position of characters in PAGE MODE	P	○	92
<a href="#">GS L</a>	Setting the left margin	S	○	93
<a href="#">GS W</a>	Setting the print area width	S-P	○	94
<a href="#">GS \</a>	Specifying the relative vertical position of a character in PAGE MODE	S-P	○	96



## Line Feed Span Commands

Command	Function	MODE	GS P	Page
<a href="#">ESC 2</a>	Specifying initial line feed rate	S·P		97
<a href="#">ESC 3</a>	Setting line feed rate of minimum pitch	S·P	○	98

## Bit Image Commands

Command	Function	MODE	GS P	Page
<a href="#">ESC *</a>	Specifying the bit image mode	S·P		99
<a href="#">GS *</a>	Defining the download bit image	S·P		100
<a href="#">GS /</a>	Printing the downloaded bit image	S·P		101
<a href="#">GS v 0</a>	Printing of raster bit image	S		102

## Status Commands

Command	Function	MODE	GS P	Page
<a href="#">DLE EOT</a>	Sending status in real-time	S·P		104
<a href="#">ESC u</a>	Transmitting the status of peripheral equipment (Serial Mode Only)	S·P		124
<a href="#">ESC v</a>	Sending Printer status	S·P		125
<a href="#">GS a</a>	Enabling/disabling ASB (Automatic Status Back)	S·P		126
<a href="#">GS r</a>	Sending status	S·P		130

## Paper Detecting Commands

Command	Function	MODE	GS P	Page
<a href="#">ESC c 3</a>	Selecting the Paper Sensor valid for Paper-end signal output	S·P		132
<a href="#">ESC c 4</a>	Selecting the Paper Near-end Sensor valid for print stop	S·P		133

## Panel Switch Commands

Command	Function	MODE	GS P	Page
<a href="#">ESC c 5</a>	Enabling/disabling the panel switches	S·P		134

## Macro Commands

Command	Function	MODE	GS P	Page
<a href="#">GS :</a>	Starting/ending macro definition	S·P		135
<a href="#">GS ^</a>	Executing the macro	S·P		136

## Cutter Commands

Command	Function	MODE	GS P	Page
<a href="#">ESC i</a>	Full cut	S·P		137
<a href="#">ESC m</a>	Partial cut	S·P		138
<a href="#">GS V</a>	Cutting the paper	S·P	○	139

## Bar Code Commands

Command	Function	MODE	GS P	Page
<a href="#">GS H</a>	Selecting of printing position of HRI characters	S·P		140
<a href="#">GS f</a>	Selecting the font of HRI characters	S·P		141
<a href="#">GS h</a>	Specifying the height of the bar code	S·P		142
<a href="#">GS k</a>	Printing the bar code	S·P		143
<a href="#">GS w</a>	Specifying the horizontal size (magnification) of bar code	S·P		149

### Commands for Non-volatile Memory

Command	Function	MODE	GS P	Page
<a href="#">FS p</a>	Printing the download NV bit images	S		166
<a href="#">FS q</a>	Defining the download NV bit image	S		167

### Kanji Control Commands

Command	Function	MODE	GS P	Page
<a href="#">FS !</a>	Collectively setting Kanji print mode	S·P		169
<a href="#">FS &amp;</a>	Setting Kanji mode	S·P		170
<a href="#">FS -</a>	Setting/Canceling Kanji underline	S·P		171
<a href="#">FS .</a>	Canceling Kanji mode	S·P		172
<a href="#">FS 2</a>	Defining external character	S·P		173
<a href="#">FS C</a>	Selecting Kanji code system	S·P		175
<a href="#">FS S</a>	Setting Kanji space amount	S·P	○	177
<a href="#">FS W</a>	Setting/Canceling four times enlargement of Kanji	S·P		178
<a href="#">FS ( A</a>	Setting font attribute of Kanji	S·P		179

### Black Mark Control Commands

Command	Function	MODE	GS P	Page
<a href="#">GS FF</a>	Printing and ejecting Black mark/Label paper	S·P		180
<a href="#">GS &lt;</a>	Initializing the printer mechanism	S·P		181
<a href="#">GS A</a>	Correcting the leader position of Black mark paper	S·P		182
<a href="#">GS C 0</a>	Setting the numbering print mode	S·P		183
<a href="#">GS C 1</a>	Setting the numbering counter mode (A)	S·P		184
<a href="#">GS C 2</a>	Setting the numbering counter	S·P		185
<a href="#">GS C ;</a>	Setting the numbering counter mode (B)	S·P		186
<a href="#">GS c</a>	Print the counter	S·P		187

### Printer Function Setting Commands

Command	Function	MODE	GS P	Page
<a href="#">GS ( D</a>	Enabling or disabling real-time command	S		191
<a href="#">GS ( E</a>	Printer function setting command	S		191
<a href="#">GS ( K</a>	Selecting print control method	S		302
<a href="#">GS ( M</a>	Customizing the printer	S		306
<a href="#">GS ( N</a>	Designating font attribute	S		309

### Other Commands

Command	Function	MODE	GS P	Page
<a href="#">DLE ENQ</a>	Real-time request to printer	S·P		328
<a href="#">DLE DC4</a>	Outputting specified pulse in real-time/Buffer clear	S·P		329/330
<a href="#">ESC =</a>	Data input control	S·P		331
<a href="#">ESC @</a>	Initializing the printer	S·P		332
<a href="#">ESC L</a>	Selecting PAGE MODE	S		333
<a href="#">ESC S</a>	Selecting STANDARD MODE	P		334
<a href="#">ESC p</a>	Generating the specified pulses	S·P		335
<a href="#">GS ( A</a>	Execution of test printing	S		336
<a href="#">GS I</a>	Sending the printer ID	S·P		337
<a href="#">GS P</a>	Specifying the basic calculation pitch	S·P		348
<a href="#">ESC RS</a>	Sound buzzer	S·P		349

In the Mode column: S = STANDARD MODE, P = PAGE MODE  
 O = shows the command affected by GS P.

## 2.1.4 CT-S310

### Print Control Commands

Command	Function	MODE	GS P	Page
<a href="#">LF</a>	Printing and paper feed	S-P		53
<a href="#">CR</a>	Back to printing	S-P		54
<a href="#">FF</a>	(1)Printing in PAGE MODE and returning to STANDARD MODE (at the selection of PAGE MODE) (2)Printing of Black mark/Label paper and feeding paper to the top of the print position (with Black mark/Label paper selected)	P		55
<a href="#">ESC FF</a>	Printing data in PAGE MODE	P		56
<a href="#">ESC J</a>	Printing and feeding paper in minimum pitch	S-P	○	57
<a href="#">ESC d</a>	Printing and feeding the paper by "n" lines	S-P		58

### Print Character Commands

Command	Function	MODE	GS P	Page
<a href="#">CAN</a>	Canceling print data in PAGE MODE	P		59
<a href="#">ESC SP</a>	Setting the right spacing of the character	S-P	○	60
<a href="#">ESC !</a>	Collectively specifying the printing mode	S-P		61
<a href="#">ESC %</a>	Specifying/Canceling download character set	S-P		63
<a href="#">ESC &amp;</a>	Defining the download characters	S-P		64
<a href="#">ESC -</a>	Specifying/canceling underline	S-P		66
<a href="#">ESC ?</a>	Deleting download characters	S-P		67
<a href="#">ESC E</a>	Specifying/canceling emphasis printing	S-P		68
<a href="#">ESC G</a>	Specifying/canceling double strike printing	S-P		69
<a href="#">ESC M</a>	Selection of character fonts	S-P		70
<a href="#">ESC R</a>	Selecting the international character set	S-P		71
<a href="#">ESC V</a>	Specifying/canceling 90°-right-turned characters	S		72
<a href="#">ESC t</a>	Selecting the character code table	S-P		73
<a href="#">ESC {</a>	Specifying/canceling the inverted characters	S		74
<a href="#">ESC ~ J</a>	Specifies/cancels printing in red (black-based paper)	S-P		76
<a href="#">DC3</a>	Specifies/cancels printing in red (black-based paper)	S		79
<a href="#">GS !</a>	Specifying the character size	S-P		80
<a href="#">GS B</a>	Specifying/canceling the black/white inverted printing	S-P		82
<a href="#">GS b</a>	Specifying/canceling the smoothing	S-P		83

### Print Position Commands

Command	Function	MODE	GS P	Page
<a href="#">HT</a>	Horizontal tab	S-P		84
<a href="#">ESC \$</a>	Specifying the absolute positions	S-P	○	85
<a href="#">ESC D</a>	Setting horizontal tab position	S-P		86
<a href="#">ESC T</a>	Selecting the character printing direction in PAGE MODE	P		87
<a href="#">ESC W</a>	Defining the print area in PAGE MODE	P	○	88
<a href="#">ESC \</a>	Specifying the relative position	S-P	○	90
<a href="#">ESC a</a>	Aligning the characters	S		91
<a href="#">GS \$</a>	Specifying the absolute vertical position of characters in PAGE MODE	P	○	92
<a href="#">GS L</a>	Setting the left margin	S	○	93
<a href="#">GS W</a>	Setting the print area width	S-P	○	94
<a href="#">GS \</a>	Specifying the relative vertical position of a character in PAGE MODE	S-P	○	96

### Line Feed Span Commands

Command	Function	MODE	GS P	Page
<a href="#">ESC 2</a>	Specifying initial line feed rate	S·P		97
<a href="#">ESC 3</a>	Setting line feed rate of minimum pitch	S·P	○	98

### Bit Image Commands

Command	Function	MODE	GS P	Page
<a href="#">ESC *</a>	Specifying the bit image mode	S·P		99
<a href="#">GS *</a>	Defining the download bit image	S·P		100
<a href="#">GS /</a>	Printing the downloaded bit image	S·P		101
<a href="#">GS v 0</a>	Printing of raster bit image	S		102

### Status Commands

Command	Function	MODE	GS P	Page
<a href="#">DLE EOT</a>	Sending status in real-time	S·P		104
<a href="#">ESC u</a>	Transmitting the status of peripheral equipment (Serial Mode Only)	S·P		124
<a href="#">ESC v</a>	Sending Printer status	S·P		125
<a href="#">GS a</a>	Enabling/disabling ASB (Automatic Status Back)	S·P		126
<a href="#">GS r</a>	Sending status	S·P		130

### Paper Detecting Commands

Command	Function	MODE	GS P	Page
<a href="#">ESC c 3</a>	Selecting the Paper Sensor valid for Paper-end signal output	S·P		132
<a href="#">ESC c 4</a>	Selecting the Paper Near-end Sensor valid for print stop	S·P		133

### Panel Switch Commands

Command	Function	MODE	GS P	Page
<a href="#">ESC c 5</a>	Enabling/disabling the panel switches	S·P		134

### Macro Commands

Command	Function	MODE	GS P	Page
<a href="#">GS :</a>	Starting/ending macro definition	S·P		135
<a href="#">GS ^</a>	Executing the macro	S·P		136

### Cutter Commands

Command	Function	MODE	GS P	Page
<a href="#">ESC i</a>	Full cut	S·P		137
<a href="#">ESC m</a>	Partial cut	S·P		138
<a href="#">GS V</a>	Cutting the paper	S·P	○	139

### Bar Code Commands

Command	Function	MODE	GS P	Page
<a href="#">GS H</a>	Selecting of printing position of HRI characters	S·P		140
<a href="#">GS f</a>	Selecting the font of HRI characters	S·P		141
<a href="#">GS h</a>	Specifying the height of the bar code	S·P		142
<a href="#">GS k</a>	Printing the bar code	S·P		143
<a href="#">GS w</a>	Specifying the horizontal size (magnification) of bar code	S·P		149

### Commands for Non-volatile Memory

Command	Function	MODE	GS P	Page
<a href="#">FS p</a>	Printing the download NV bit images	S		166
<a href="#">FS q</a>	Defining the download NV bit image	S		167

### Kanji Control Commands

Command	Function	MODE	GS P	Page
<a href="#">FS !</a>	Collectively setting Kanji print mode	S·P		169
<a href="#">FS &amp;</a>	Setting Kanji mode	S·P		170
<a href="#">FS -</a>	Setting/Canceling Kanji underline	S·P		171
<a href="#">FS .</a>	Canceling Kanji mode	S·P		172
<a href="#">FS 2</a>	Defining external character	S·P		173
<a href="#">FS C</a>	Selecting Kanji code system	S·P		175
<a href="#">FS S</a>	Setting Kanji space amount	S·P	○	177
<a href="#">FS W</a>	Setting/Canceling four times enlargement of Kanji	S·P		178
<a href="#">FS ( A</a>	Setting font attribute of Kanji	S·P		179

### Black Mark Control Commands

Command	Function	MODE	GS P	Page
<a href="#">GS FF</a>	Printing and ejecting Black mark/Label paper	S·P		180
<a href="#">GS &lt;</a>	Initializing the printer mechanism	S·P		181

### Printer Function Setting Commands

Command	Function	MODE	GS P	Page
<a href="#">GS ( D</a>	Enabling or disabling real-time command	S		191
<a href="#">GS ( E</a>	Printer function setting command	S		191
<a href="#">GS ( K</a>	Selecting print control method	S		302
<a href="#">GS ( M</a>	Customizing the printer	S		306
<a href="#">GS ( N</a>	Designating font attribute	S		309

### 2-dimensional Code Commands

Command	Function	MODE	GS P	Page
<a href="#">GS ( k</a>	Setting and printing 2-dimensional code	S·P		310

### Other Commands

Command	Function	MODE	GS P	Page
<a href="#">DLE ENQ</a>	Real-time request to printer	S·P		328
<a href="#">DLE DC4</a>	Outputting specified pulse in real-time/Buffer clear	S·P		329/330
<a href="#">ESC =</a>	Data input control	S·P		331
<a href="#">ESC @</a>	Initializing the printer	S·P		332
<a href="#">ESC L</a>	Selecting PAGE MODE	S		333
<a href="#">ESC S</a>	Selecting STANDARD MODE	P		334
<a href="#">ESC p</a>	Generating the specified pulses	S·P		335
<a href="#">GS ( A</a>	Execution of test printing	S		336
<a href="#">GS I</a>	Sending the printer ID	S·P		337
<a href="#">GS P</a>	Specifying the basic calculation pitch	S·P		348
<a href="#">ESC RS</a>	Sound buzzer	S·P		349

In the Mode column: S = STANDARD MODE, P = PAGE MODE  
 O = shows the command affected by GS P.

## 2.1.5 CT-S310II

### Print Control Commands

Command	Function	MODE	GS P	Page
<a href="#">LF</a>	Printing and paper feed	S-P		53
<a href="#">CR</a>	Back to printing	S-P		54
<a href="#">FF</a>	(1)Printing in PAGE MODE and returning to STANDARD MODE (at the selection of PAGE MODE) (2)Printing of Black mark/Label paper and feeding paper to the top of the print position (with Black mark/Label paper selected)	P		55
<a href="#">ESC FF</a>	Printing data in PAGE MODE	P		56
<a href="#">ESC J</a>	Printing and feeding paper in minimum pitch	S-P	○	57
<a href="#">ESC d</a>	Printing and feeding the paper by "n" lines	S-P		58

### Print Character Commands

Command	Function	MODE	GS P	Page
<a href="#">CAN</a>	Canceling print data in PAGE MODE	P		59
<a href="#">ESC SP</a>	Setting the right spacing of the character	S-P	○	60
<a href="#">ESC !</a>	Collectively specifying the printing mode	S-P		61
<a href="#">ESC %</a>	Specifying/Canceling download character set	S-P		63
<a href="#">ESC &amp;</a>	Defining the download characters	S-P		64
<a href="#">ESC -</a>	Specifying/canceling underline	S-P		66
<a href="#">ESC ?</a>	Deleting download characters	S-P		67
<a href="#">ESC E</a>	Specifying/canceling emphasis printing	S-P		68
<a href="#">ESC G</a>	Specifying/canceling double strike printing	S-P		69
<a href="#">ESC M</a>	Selection of character fonts	S-P		70
<a href="#">ESC R</a>	Selecting the international character set	S-P		71
<a href="#">ESC V</a>	Specifying/canceling 90°-right-turned characters	S		72
<a href="#">ESC t</a>	Selecting the character code table	S-P		73
<a href="#">ESC {</a>	Specifying/canceling the inverted characters	S		74
<a href="#">GS !</a>	Specifying the character size	S-P		80
<a href="#">GS B</a>	Specifying/canceling the black/white inverted printing	S-P		82
<a href="#">GS b</a>	Specifying/canceling the smoothing	S-P		83

### Print Position Commands

Command	Function	MODE	GS P	Page
<a href="#">HT</a>	Horizontal tab	S-P		84
<a href="#">ESC \$</a>	Specifying the absolute positions	S-P	○	85
<a href="#">ESC D</a>	Setting horizontal tab position	S-P		86
<a href="#">ESC T</a>	Selecting the character printing direction in PAGE MODE	P		87
<a href="#">ESC W</a>	Defining the print area in PAGE MODE	P	○	88
<a href="#">ESC \</a>	Specifying the relative position	S-P	○	90
<a href="#">ESC a</a>	Aligning the characters	S		91
<a href="#">GS \$</a>	Specifying the absolute vertical position of characters in PAGE MODE	P	○	92
<a href="#">GS L</a>	Setting the left margin	S	○	93
<a href="#">GS W</a>	Setting the print area width	S-P	○	94
<a href="#">GS  </a>	Specifying the relative vertical position of a character in PAGE MODE	S-P	○	96

### Line Feed Span Commands

Command	Function	MODE	GS P	Page
<a href="#">ESC 2</a>	Specifying initial line feed rate	S·P		97
<a href="#">ESC 3</a>	Setting line feed rate of minimum pitch	S·P	○	98

### Bit Image Commands

Command	Function	MODE	GS P	Page
<a href="#">ESC *</a>	Specifying the bit image mode	S·P		99
<a href="#">GS *</a>	Defining the download bit image	S·P		100
<a href="#">GS /</a>	Printing the downloaded bit image	S·P		101
<a href="#">GS v 0</a>	Printing of raster bit image	S		102

### Status Commands

Command	Function	MODE	GS P	Page
<a href="#">DLE EOT</a>	Sending status in real-time	S·P		104
<a href="#">ESC u</a>	Transmitting the status of peripheral equipment (Serial Mode Only)	S·P		124
<a href="#">ESC v</a>	Sending Printer status	S·P		125
<a href="#">GS a</a>	Enabling/disabling ASB (Automatic Status Back)	S·P		126
<a href="#">GS r</a>	Sending status	S·P		130

### Paper Detecting Commands

Command	Function	MODE	GS P	Page
<a href="#">ESC c 3</a>	Selecting the Paper Sensor valid for Paper-end signal output	S·P		132

### Panel Switch Commands

Command	Function	MODE	GS P	Page
<a href="#">ESC c 5</a>	Enabling/disabling the panel switches	S·P		134

### Macro Commands

Command	Function	MODE	GS P	Page
<a href="#">GS :</a>	Starting/ending macro definition	S·P		135
<a href="#">GS ^</a>	Executing the macro	S·P		136

### Cutter Commands

Command	Function	MODE	GS P	Page
<a href="#">ESC i</a>	Full cut	S·P		137
<a href="#">ESC m</a>	Partial cut	S·P		138
<a href="#">GS V</a>	Cutting the paper	S·P	○	139

### Bar Code Commands

Command	Function	MODE	GS P	Page
<a href="#">GS H</a>	Selecting of printing position of HRI characters	S·P		140
<a href="#">GS f</a>	Selecting the font of HRI characters	S·P		141
<a href="#">GS h</a>	Specifying the height of the bar code	S·P		142
<a href="#">GS k</a>	Printing the bar code	S·P		143
<a href="#">GS w</a>	Specifying the horizontal size (magnification) of bar code	S·P		149

### Commands for Non-volatile Memory

Command	Function	MODE	GSP	Page
<a href="#">GS ( C</a>	Editing user NV memory	S		150
<a href="#">GS ( L</a> <a href="#">GS 8 L</a>	Specifying graphics data	S		156
<a href="#">GS g 0</a>	Initializing maintenance counter	S		164
<a href="#">GS g 2</a>	Sending maintenance counter	S		165
<a href="#">FS p</a>	Printing the download NV bit images	S		166
<a href="#">FS q</a>	Defining the download NV bit image	S		167

### Kanji Control Commands

Command	Function	MODE	GSP	Page
<a href="#">FS !</a>	Collectively setting Kanji print mode	S·P		169
<a href="#">FS &amp;</a>	Setting Kanji mode	S·P		170
<a href="#">FS -</a>	Setting/Canceling Kanji underline	S·P		171
<a href="#">FS .</a>	Canceling Kanji mode	S·P		172
<a href="#">FS 2</a>	Defining external character	S·P		173
<a href="#">FS C</a>	Selecting Kanji code system	S·P		175
<a href="#">FS S</a>	Setting Kanji space amount	S·P	○	177
<a href="#">FS W</a>	Setting/Canceling four times enlargement of Kanji	S·P		178
<a href="#">FS ( A</a>	Setting font attribute of Kanji	S·P		179

### Printer Function Setting Commands

Command	Function	MODE	GSP	Page
<a href="#">GS ( D</a>	Enabling or disabling real-time command	S		191
<a href="#">GS ( E</a>	Printer function setting command	S		191
<a href="#">GS ( K</a>	Selecting print control method	S		302
<a href="#">GS ( M</a>	Customizing the printer	S		306
<a href="#">GS ( N</a>	Designating font attribute	S		309

### 2-dimensional Code Commands

Command	Function	MODE	GSP	Page
<a href="#">GS ( k</a>	Setting and printing 2-dimensional code	S·P		310



## Other Commands

Command	Function	MODE	GS P	Page
<a href="#">DLE ENQ</a>	Real-time request to printer	S·P		328
<a href="#">DLE DC4</a>	Outputting specified pulse in real-time/Buffer clear	S·P		329/330
<a href="#">ESC =</a>	Data input control	S·P		331
<a href="#">ESC @</a>	Initializing the printer	S·P		332
<a href="#">ESC L</a>	Selecting PAGE MODE	S		333
<a href="#">ESC S</a>	Selecting STANDARD MODE	P		334
<a href="#">ESC p</a>	Generating the specified pulses	S·P		335
<a href="#">GS ( A</a>	Execution of test printing	S		336
<a href="#">GS I</a>	Sending the printer ID	S·P		337
<a href="#">GS P</a>	Specifying the basic calculation pitch	S·P		348
<a href="#">ESC RS</a>	Sound buzzer	S·P		349

In the Mode column: S = STANDARD MODE, P = PAGE MODE  
O = shows the command affected by GS P.

## 2.1.6 CT-S2000

### Print Control Commands

Command	Function	MODE	GS P	Page
<a href="#">LF</a>	Printing and paper feed	S-P		53
<a href="#">CR</a>	Back to printing	S-P		54
<a href="#">FF</a>	(1)Printing in PAGE MODE and returning to STANDARD MODE (at the selection of PAGE MODE) (2)Printing of Black mark/Label paper and feeding paper to the top of the print position (with Black mark/Label paper selected)	P		55
<a href="#">ESC FF</a>	Printing data in PAGE MODE	P		56
<a href="#">ESC J</a>	Printing and feeding paper in minimum pitch	S-P	○	57
<a href="#">ESC d</a>	Printing and feeding the paper by "n" lines	S-P		58

### Print Character Commands

Command	Function	MODE	GS P	Page
<a href="#">CAN</a>	Canceling print data in PAGE MODE	P		59
<a href="#">ESC SP</a>	Setting the right spacing of the character	S-P	○	60
<a href="#">ESC !</a>	Collectively specifying the printing mode	S-P		61
<a href="#">ESC %</a>	Specifying/Canceling download character set	S-P		63
<a href="#">ESC &amp;</a>	Defining the download characters	S-P		64
<a href="#">ESC -</a>	Specifying/canceling underline	S-P		66
<a href="#">ESC ?</a>	Deleting download characters	S-P		67
<a href="#">ESC E</a>	Specifying/canceling emphasis printing	S-P		68
<a href="#">ESC G</a>	Specifying/canceling double strike printing	S-P		69
<a href="#">ESC M</a>	Selection of character fonts	S-P		70
<a href="#">ESC R</a>	Selecting the international character set	S-P		71
<a href="#">ESC V</a>	Specifying/canceling 90°-right-turned characters	S		72
<a href="#">ESC t</a>	Selecting the character code table	S-P		73
<a href="#">ESC {</a>	Specifying/canceling the inverted characters	S		74
<a href="#">ESC ~ J</a>	Specifies/cancels printing in red (black-based paper)	S-P		76
<a href="#">DC3</a>	Specifies/cancels printing in red (black-based paper)	S		79
<a href="#">GS !</a>	Specifying the character size	S-P		80
<a href="#">GS B</a>	Specifying/canceling the black/white inverted printing	S-P		82
<a href="#">GS b</a>	Specifying/canceling the smoothing	S-P		83

### Print Position Commands

Command	Function	MODE	GS P	Page
<a href="#">HT</a>	Horizontal tab	S-P		84
<a href="#">ESC \$</a>	Specifying the absolute positions	S-P	○	85
<a href="#">ESC D</a>	Setting horizontal tab position	S-P		86
<a href="#">ESC T</a>	Selecting the character printing direction in PAGE MODE	P		87
<a href="#">ESC W</a>	Defining the print area in PAGE MODE	P	○	88
<a href="#">ESC \</a>	Specifying the relative position	S-P	○	90
<a href="#">ESC a</a>	Aligning the characters	S		91
<a href="#">GS \$</a>	Specifying the absolute vertical position of characters in PAGE MODE	P	○	92
<a href="#">GS L</a>	Setting the left margin	S	○	93
<a href="#">GS W</a>	Setting the print area width	S-P	○	94
<a href="#">GS \</a>	Specifying the relative vertical position of a character in PAGE MODE	S-P	○	96

### Line Feed Span Commands

Command	Function	MODE	GS P	Page
<a href="#">ESC 2</a>	Specifying initial line feed rate	S·P		97
<a href="#">ESC 3</a>	Setting line feed rate of minimum pitch	S·P	○	98

### Bit Image Commands

Command	Function	MODE	GS P	Page
<a href="#">ESC *</a>	Specifying the bit image mode	S·P		99
<a href="#">GS *</a>	Defining the download bit image	S·P		100
<a href="#">GS /</a>	Printing the downloaded bit image	S·P		101
<a href="#">GS v 0</a>	Printing of raster bit image	S		102

### Status Commands

Command	Function	MODE	GS P	Page
<a href="#">DLE EOT</a>	Sending status in real-time	S·P		104
<a href="#">ESC u</a>	Transmitting the status of peripheral equipment (Serial Mode Only)	S·P		124
<a href="#">ESC v</a>	Sending Printer status	S·P		125
<a href="#">GS a</a>	Enabling/disabling ASB (Automatic Status Back)	S·P		126
<a href="#">GS r</a>	Sending status	S·P		130

### Paper Detecting Commands

Command	Function	MODE	GS P	Page
<a href="#">ESC c 3</a>	Selecting the Paper Sensor valid for Paper-end signal output	S·P		132
<a href="#">ESC c 4</a>	Selecting the Paper Near-end Sensor valid for print stop	S·P		133

### Panel Switch Commands

Command	Function	MODE	GS P	Page
<a href="#">ESC c 5</a>	Enabling/disabling the panel switches	S·P		134

### Macro Commands

Command	Function	MODE	GS P	Page
<a href="#">GS :</a>	Starting/ending macro definition	S·P		135
<a href="#">GS ^</a>	Executing the macro	S·P		136

### Cutter Commands

Command	Function	MODE	GS P	Page
<a href="#">ESC i</a>	Full cut	S·P		137
<a href="#">ESC m</a>	Partial cut	S·P		138
<a href="#">GS V</a>	Cutting the paper	S·P	○	139

### Bar Code Commands

Command	Function	MODE	GS P	Page
<a href="#">GS H</a>	Selecting of printing position of HRI characters	S·P		140
<a href="#">GS f</a>	Selecting the font of HRI characters	S·P		141
<a href="#">GS h</a>	Specifying the height of the bar code	S·P		142
<a href="#">GS k</a>	Printing the bar code	S·P		143
<a href="#">GS w</a>	Specifying the horizontal size (magnification) of bar code	S·P		149

### Commands for Non-volatile Memory

Command	Function	MODE	GS P	Page
<a href="#">GS ( C</a>	Editing user NV memory	S		150
<a href="#">GS ( L</a> <a href="#">GS 8 L</a>	Specifying graphics data	S		156
<a href="#">GS g 0</a>	Initializing maintenance counter	S		164
<a href="#">GS g 2</a>	Sending maintenance counter	S		165
<a href="#">FS p</a>	Printing the download NV bit images	S		166
<a href="#">FS q</a>	Defining the download NV bit image	S		167

### Kanji Control Commands

Command	Function	MODE	GS P	Page
<a href="#">FS !</a>	Collectively setting Kanji print mode	S·P		169
<a href="#">FS &amp;</a>	Setting Kanji mode	S·P		170
<a href="#">FS -</a>	Setting/Canceling Kanji underline	S·P		171
<a href="#">FS .</a>	Canceling Kanji mode	S·P		172
<a href="#">FS 2</a>	Defining external character	S·P		173
<a href="#">FS C</a>	Selecting Kanji code system	S·P		175
<a href="#">FS S</a>	Setting Kanji space amount	S·P	○	177
<a href="#">FS W</a>	Setting/Canceling four times enlargement of Kanji	S·P		178
<a href="#">FS ( A</a>	Setting font attribute of Kanji	S·P		179

### Black Mark and Label Control Commands

Command	Function	MODE	GS P	Page
<a href="#">GS FF</a>	Printing and ejecting Black mark paper/Label Paper	S·P		180
<a href="#">GS &lt;</a>	Initializing the printer mechanism	S·P		181
<a href="#">GS A</a>	Correcting the leader position of Black mark/Label paper	S·P		182
<a href="#">GS C 0</a>	Setting the numbering print mode	S·P		183
<a href="#">GS C 1</a>	Setting the numbering counter mode (A)	S·P		184
<a href="#">GS C 2</a>	Setting the numbering counter	S·P		185
<a href="#">GS C ;</a>	Setting the numbering counter mode (B)	S·P		186
<a href="#">GS c</a>	Print the counter	S·P		187
<a href="#">GS l</a>	Setting the Black mark/Label length	S·P		188

### Printer Function Setting Commands

Command	Function	MODE	GS P	Page
<a href="#">GS ( D</a>	Enabling or disabling real-time command	S		191
<a href="#">GS ( E</a>	Printer function setting command	S		191
<a href="#">GS ( K</a>	Selecting print control method	S		302
<a href="#">GS ( M</a>	Customizing the printer	S		306
<a href="#">GS ( N</a>	Designating font attribute	S		309

### 2-dimensional Code Commands

Command	Function	MODE	GS P	Page
<a href="#">GS ( k</a>	Setting and printing 2-dimensional code	S·P		310

## Other Commands

Command	Function	MODE	GS P	Page
<a href="#">DLE ENQ</a>	Real-time request to printer	S·P		328
<a href="#">DLE DC4</a>	Outputting specified pulse in real-time/Buffer clear	S·P		329/330
<a href="#">ESC =</a>	Data input control	S·P		331
<a href="#">ESC @</a>	Initializing the printer	S·P		332
<a href="#">ESC L</a>	Selecting PAGE MODE	S		333
<a href="#">ESC S</a>	Selecting STANDARD MODE	P		334
<a href="#">ESC p</a>	Generating the specified pulses	S·P		335
<a href="#">GS ( A</a>	Execution of test printing	S		336
<a href="#">GS I</a>	Sending the printer ID	S·P		337
<a href="#">GS P</a>	Specifying the basic calculation pitch	S·P		348
<a href="#">ESC RS</a>	Sound buzzer	S·P		349

In the Mode column: S = STANDARD MODE, P = PAGE MODE  
O = shows the command affected by GS P.

## 2.1.7 CT-S4000

### Print Control Commands

Command	Function	MODE	GS P	Page
<a href="#">LF</a>	Printing and paper feed	S·P		53
<a href="#">CR</a>	Back to printing	S·P		54
<a href="#">FF</a>	(1)Printing in PAGE MODE and returning to STANDARD MODE (at the selection of PAGE MODE) (2)Printing of Black mark/Label paper and feeding paper to the top of the print position (with Black mark/Label paper selected)	P		55
<a href="#">ESC FF</a>	Printing data in PAGE MODE	P		56
<a href="#">ESC J</a>	Printing and feeding paper in minimum pitch	S·P	○	57
<a href="#">ESC d</a>	Printing and feeding the paper by "n" lines	S·P		58

### Print Character Commands

Command	Function	MODE	GS P	Page
<a href="#">CAN</a>	Canceling print data in PAGE MODE	P		59
<a href="#">ESC SP</a>	Setting the right spacing of the character	S·P	○	60
<a href="#">ESC !</a>	Collectively specifying the printing mode	S·P		61
<a href="#">ESC %</a>	Specifying/Canceling download character set	S·P		63
<a href="#">ESC &amp;</a>	Defining the download characters	S·P		64
<a href="#">ESC -</a>	Specifying/canceling underline	S·P		66
<a href="#">ESC ?</a>	Deleting download characters	S·P		67
<a href="#">ESC E</a>	Specifying/canceling emphasis printing	S·P		68
<a href="#">ESC G</a>	Specifying/canceling double strike printing	S·P		69
<a href="#">ESC M</a>	Selection of character fonts	S·P		70
<a href="#">ESC R</a>	Selecting the international character set	S·P		71
<a href="#">ESC V</a>	Specifying/canceling 90°-right-turned characters	S		72
<a href="#">ESC t</a>	Selecting the character code table	S·P		73
<a href="#">ESC {</a>	Specifying/canceling the inverted characters	S		74
<a href="#">ESC ~ J</a>	Specifies/cancels printing in red (black-based paper)	S·P		76
<a href="#">DC3</a>	Specifies/cancels printing in red (black-based paper)	S		79
<a href="#">GS !</a>	Specifying the character size	S·P		80
<a href="#">GS B</a>	Specifying/canceling the black/white inverted printing	S·P		82
<a href="#">GS b</a>	Specifying/canceling the smoothing	S·P		83

### Print Position Commands

Command	Function	MODE	GS P	Page
<a href="#">HT</a>	Horizontal tab	S·P		84
<a href="#">ESC \$</a>	Specifying the absolute positions	S·P	○	85
<a href="#">ESC D</a>	Setting horizontal tab position	S·P		86
<a href="#">ESC T</a>	Selecting the character printing direction in PAGE MODE	P		87
<a href="#">ESC W</a>	Defining the print area in PAGE MODE	P	○	88
<a href="#">ESC \</a>	Specifying the relative position	S·P	○	90
<a href="#">ESC a</a>	Aligning the characters	S		91
<a href="#">GS \$</a>	Specifying the absolute vertical position of characters in PAGE MODE	P	○	92
<a href="#">GS L</a>	Setting the left margin	S	○	93
<a href="#">GS W</a>	Setting the print area width	S·P	○	94
<a href="#">GS \</a>	Specifying the relative vertical position of a character in PAGE MODE	S·P	○	96

### Line Feed Span Commands

Command	Function	MODE	GS P	Page
<a href="#">ESC 2</a>	Specifying initial line feed rate	S·P		97
<a href="#">ESC 3</a>	Setting line feed rate of minimum pitch	S·P	○	98

### Bit Image Commands

Command	Function	MODE	GS P	Page
<a href="#">ESC *</a>	Specifying the bit image mode	S·P		99
<a href="#">GS *</a>	Defining the download bit image	S·P		100
<a href="#">GS /</a>	Printing the downloaded bit image	S·P		101
<a href="#">GS v 0</a>	Printing of raster bit image	S		102

### Status Commands

Command	Function	MODE	GS P	Page
<a href="#">DLE EOT</a>	Sending status in real-time	S·P		104
<a href="#">ESC u</a>	Transmitting the status of peripheral equipment (Serial Mode Only)	S·P		124
<a href="#">ESC v</a>	Sending Printer status	S·P		125
<a href="#">GS a</a>	Enabling/disabling ASB (Automatic Status Back)	S·P		126
<a href="#">GS r</a>	Sending status	S·P		130

### Paper Detecting Commands

Command	Function	MODE	GS P	Page
<a href="#">ESC c 3</a>	Selecting the Paper Sensor valid for Paper-end signal output	S·P		132
<a href="#">ESC c 4</a>	Selecting the Paper Near-end Sensor valid for print stop	S·P		133

### Panel Switch Commands

Command	Function	MODE	GS P	Page
<a href="#">ESC c 5</a>	Enabling/disabling the panel switches	S·P		134

### Macro Commands

Command	Function	MODE	GS P	Page
<a href="#">GS :</a>	Starting/ending macro definition	S·P		135
<a href="#">GS ^</a>	Executing the macro	S·P		136

### Cutter Commands

Command	Function	MODE	GS P	Page
<a href="#">ESC i</a>	Full cut	S·P		137
<a href="#">ESC m</a>	Partial cut	S·P		138
<a href="#">GS V</a>	Cutting the paper	S·P	○	139

### Bar Code Commands

Command	Function	MODE	GS P	Page
<a href="#">GS H</a>	Selecting of printing position of HRI characters	S·P		140
<a href="#">GS f</a>	Selecting the font of HRI characters	S·P		141
<a href="#">GS h</a>	Specifying the height of the bar code	S·P		142
<a href="#">GS k</a>	Printing the bar code	S·P		143
<a href="#">GS w</a>	Specifying the horizontal size (magnification) of bar code	S·P		149

## Commands for Non-volatile Memory

Command	Function	MODE	GS P	Page
<a href="#">GS ( C</a>	Editing user NV memory	S		150
<a href="#">GS ( L</a> <a href="#">GS 8 L</a>	Specifying graphics data	S		156
<a href="#">GS g 0</a>	Initializing maintenance counter	S		164
<a href="#">GS g 2</a>	Sending maintenance counter	S		165
<a href="#">FS p</a>	Printing the download NV bit images	S		166
<a href="#">FS q</a>	Defining the download NV bit image	S		167

## Kanji Control Commands

Command	Function	MODE	GS P	Page
<a href="#">FS !</a>	Collectively setting Kanji print mode	S·P		169
<a href="#">FS &amp;</a>	Setting Kanji mode	S·P		170
<a href="#">FS -</a>	Setting/Canceling Kanji underline	S·P		171
<a href="#">FS .</a>	Canceling Kanji mode	S·P		172
<a href="#">FS 2</a>	Defining external character	S·P		173
<a href="#">FS C</a>	Selecting Kanji code system	S·P		175
<a href="#">FS S</a>	Setting Kanji space amount	S·P	○	177
<a href="#">FS W</a>	Setting/Canceling four times enlargement of Kanji	S·P		178
<a href="#">FS ( A</a>	Setting font attribute of Kanji	S·P		179

## Black Mark and Label Control Commands

Command	Function	MODE	GS P	Page
<a href="#">GS FF</a>	Printing and ejecting Black mark paper/Label Paper	S·P		180
<a href="#">GS &lt;</a>	Initializing the printer mechanism	S·P		181
<a href="#">GS A</a>	Correcting the leader position of Black mark/Label paper	S·P		182
<a href="#">GS C 0</a>	Setting the numbering print mode	S·P		183
<a href="#">GS C 1</a>	Setting the numbering counter mode (A)	S·P		184
<a href="#">GS C 2</a>	Setting the numbering counter	S·P		185
<a href="#">GS C ;</a>	Setting the numbering counter mode (B)	S·P		186
<a href="#">GS c</a>	Print the counter	S·P		187
<a href="#">GS l</a>	Setting the Black mark/Label length	S·P		188
<a href="#">GS p</a>	Changing the paper type	S·P		189

## Printer Function Setting Commands

Command	Function	MODE	GS P	Page
<a href="#">GS ( D</a>	Enabling or disabling real-time command	S		191
<a href="#">GS ( E</a>	Printer function setting command	S		191
<a href="#">GS ( K</a>	Selecting print control method	S		302
<a href="#">GS ( M</a>	Customizing the printer	S		306
<a href="#">GS ( N</a>	Designating font attribute	S		309

## 2-dimensional Code Commands

Command	Function	MODE	GS P	Page
<a href="#">GS ( k</a>	Setting and printing 2-dimensional code	S·P		310



## Other Commands

Command	Function	MODE	GS P	Page
<a href="#">DLE ENQ</a>	Real-time request to printer	S·P		328
<a href="#">DLE DC4</a>	Outputting specified pulse in real-time/Buffer clear	S·P		329/330
<a href="#">ESC =</a>	Data input control	S·P		331
<a href="#">ESC @</a>	Initializing the printer	S·P		332
<a href="#">ESC L</a>	Selecting PAGE MODE	S		333
<a href="#">ESC S</a>	Selecting STANDARD MODE	P		334
<a href="#">ESC p</a>	Generating the specified pulses	S·P		335
<a href="#">GS ( A</a>	Execution of test printing	S		336
<a href="#">GS I</a>	Sending the printer ID	S·P		337
<a href="#">GS P</a>	Specifying the basic calculation pitch	S·P		348
<a href="#">ESC RS</a>	Sound buzzer	S·P		349

In the Mode column: S = STANDARD MODE, P = PAGE MODE  
 O = shows the command affected by GS P.

## 2.1.8 CT-S601/651/801/851

### Print Control Commands

Command	Function	MODE	GS P	Page
<a href="#">LF</a>	Printing and paper feed	S-P		53
<a href="#">CR</a>	Back to printing	S-P		54
<a href="#">FF</a>	(1)Printing in PAGE MODE and returning to STANDARD MODE (at the selection of PAGE MODE) (2)Printing of Black mark/Label paper and feeding paper to the top of the print position (with Black mark/Label paper selected)	P		55
<a href="#">ESC FF</a>	Printing data in PAGE MODE	P		56
<a href="#">ESC J</a>	Printing and feeding paper in minimum pitch	S-P	○	57
<a href="#">ESC d</a>	Printing and feeding the paper by "n" lines	S-P		58

### Print Character Commands

Command	Function	MODE	GS P	Page
<a href="#">CAN</a>	Canceling print data in PAGE MODE	P		59
<a href="#">ESC SP</a>	Setting the right spacing of the character	S-P	○	60
<a href="#">ESC !</a>	Collectively specifying the printing mode	S-P		61
<a href="#">ESC %</a>	Specifying/Canceling download character set	S-P		63
<a href="#">ESC &amp;</a>	Defining the download characters	S-P		64
<a href="#">ESC -</a>	Specifying/canceling underline	S-P		66
<a href="#">ESC ?</a>	Deleting download characters	S-P		67
<a href="#">ESC E</a>	Specifying/canceling emphasis printing	S-P		68
<a href="#">ESC G</a>	Specifying/canceling double strike printing	S-P		69
<a href="#">ESC M</a>	Selection of character fonts	S-P		70
<a href="#">ESC R</a>	Selecting the international character set	S-P		71
<a href="#">ESC V</a>	Specifying/canceling 90°-right-turned characters	S		72
<a href="#">ESC t</a>	Selecting the character code table	S-P		73
<a href="#">ESC {</a>	Specifying/canceling the inverted characters	S		74
<a href="#">ESC ~ J</a>	Specifies/cancels printing in red (black-based paper)	S-P		76
<a href="#">DC3</a>	Specifies/cancels printing in red (black-based paper)	S		79
<a href="#">GS !</a>	Specifying the character size	S-P		80
<a href="#">GS B</a>	Specifying/canceling the black/white inverted printing	S-P		82
<a href="#">GS b</a>	Specifying/canceling the smoothing	S-P		83

### Print Position Commands

Command	Function	MODE	GS P	Page
<a href="#">HT</a>	Horizontal tab	S-P		84
<a href="#">ESC \$</a>	Specifying the absolute positions	S-P	○	85
<a href="#">ESC D</a>	Setting horizontal tab position	S-P		86
<a href="#">ESC T</a>	Selecting the character printing direction in PAGE MODE	P		87
<a href="#">ESC W</a>	Defining the print area in PAGE MODE	P	○	88
<a href="#">ESC \</a>	Specifying the relative position	S-P	○	90
<a href="#">ESC a</a>	Aligning the characters	S		91
<a href="#">GS \$</a>	Specifying the absolute vertical position of characters in PAGE MODE	P	○	92
<a href="#">GS L</a>	Setting the left margin	S	○	93
<a href="#">GS W</a>	Setting the print area width	S-P	○	94
<a href="#">GS \</a>	Specifying the relative vertical position of a character in PAGE MODE	S-P	○	96

### Line Feed Span Commands

Command	Function	MODE	GS P	Page
<a href="#">ESC 2</a>	Specifying initial line feed rate	S·P		97
<a href="#">ESC 3</a>	Setting line feed rate of minimum pitch	S·P	○	98

### Bit Image Commands

Command	Function	MODE	GS P	Page
<a href="#">ESC *</a>	Specifying the bit image mode	S·P		99
<a href="#">GS *</a>	Defining the download bit image	S·P		100
<a href="#">GS /</a>	Printing the downloaded bit image	S·P		101
<a href="#">GS v 0</a>	Printing of raster bit image	S		102

### Status Commands

Command	Function	MODE	GS P	Page
<a href="#">DLE EOT</a>	Sending status in real-time	S·P		104
<a href="#">ESC u</a>	Transmitting the status of peripheral equipment (Serial Mode Only)	S·P		124
<a href="#">ESC v</a>	Sending Printer status	S·P		125
<a href="#">GS a</a>	Enabling/disabling ASB (Automatic Status Back)	S·P		126
<a href="#">GS r</a>	Sending status	S·P		130

### Paper Detecting Commands

Command	Function	MODE	GS P	Page
<a href="#">ESC c 3</a>	Selecting the Paper Sensor valid for Paper-end signal output	S·P		132
<a href="#">ESC c 4</a>	Selecting the Paper Near-end Sensor valid for print stop	S·P		133

### Panel Switch Commands

Command	Function	MODE	GS P	Page
<a href="#">ESC c 5</a>	Enabling/disabling the panel switches	S·P		134

### Macro Commands

Command	Function	MODE	GS P	Page
<a href="#">GS :</a>	Starting/ending macro definition	S·P		135
<a href="#">GS ^</a>	Executing the macro	S·P		136

### Cutter Commands

Command	Function	MODE	GS P	Page
<a href="#">ESC i</a>	Full cut	S·P		137
<a href="#">ESC m</a>	Partial cut	S·P		138
<a href="#">GS V</a>	Cutting the paper	S·P	○	139

### Bar Code Commands

Command	Function	MODE	GS P	Page
<a href="#">GS H</a>	Selecting of printing position of HRI characters	S·P		140
<a href="#">GS f</a>	Selecting the font of HRI characters	S·P		141
<a href="#">GS h</a>	Specifying the height of the bar code	S·P		142
<a href="#">GS k</a>	Printing the bar code	S·P		143
<a href="#">GS w</a>	Specifying the horizontal size (magnification) of bar code	S·P		149

## Commands for Non-volatile Memory

Command	Function	MODE	GS P	Page
<a href="#">GS ( C</a>	Editing user NV memory	S		150
<a href="#">GS ( L</a> <a href="#">GS 8 L</a>	Specifying graphics data	S		156
<a href="#">GS g 0</a>	Initializing maintenance counter	S		164
<a href="#">GS g 2</a>	Sending maintenance counter	S		165
<a href="#">FS p</a>	Printing the download NV bit images	S		166
<a href="#">FS q</a>	Defining the download NV bit image	S		167

## Kanji Control Commands

Command	Function	MODE	GS P	Page
<a href="#">FS !</a>	Collectively setting Kanji print mode	S-P		169
<a href="#">FS &amp;</a>	Setting Kanji mode	S-P		170
<a href="#">FS -</a>	Setting/Canceling Kanji underline	S-P		171
<a href="#">FS .</a>	Canceling Kanji mode	S-P		172
<a href="#">FS 2</a>	Defining external character	S-P		173
<a href="#">FS C</a>	Selecting Kanji code system	S-P		175
<a href="#">FS S</a>	Setting Kanji space amount	S-P	○	177
<a href="#">FS W</a>	Setting/Canceling four times enlargement of Kanji	S-P		178
<a href="#">FS ( A</a>	Setting font attribute of Kanji	S-P		179

## Black Mark and Label Control Commands

Command	Function	MODE	GS P	Page
<a href="#">GS FF</a>	Printing and ejecting Black mark/Label paper	S-P		180
<a href="#">GS &lt;</a>	Initializing the printer mechanism	S-P		181
<a href="#">GS A</a>	Correcting the leader position of Black mark/Label paper	S-P		182
<a href="#">GS C 0</a>	Setting the numbering print mode	S-P		183
<a href="#">GS C 1</a>	Setting the numbering counter mode (A)	S-P		184
<a href="#">GS C 2</a>	Setting the numbering counter	S-P		185
<a href="#">GS C ;</a>	Setting the numbering counter mode (B)	S-P		186
<a href="#">GS c</a>	Print the counter	S-P		187
<a href="#">GS l</a>	Setting the Black mark/Label length	S-P		188
<a href="#">GS p</a>	Changing the paper type	S-P		189
<a href="#">FS FF</a>	Printing and feeding paper to manual cut position	S-P		190

## Printer Function Setting Commands

Command	Function	MODE	GS P	Page
<a href="#">GS ( D</a>	Enabling or disabling real-time command	S		191
<a href="#">GS ( E</a>	Printer function setting command	S		191
<a href="#">GS ( K</a>	Selecting print control method	S		302
<a href="#">GS ( M</a>	Customizing the printer	S		306
<a href="#">GS ( N</a>	Designating font attribute	S		309

## 2-dimensional Code Commands

Command	Function	MODE	GS P	Page
<a href="#">GS ( k</a>	Setting and printing 2-dimensional code	S-P		310

## Other Commands

Command	Function	MODE	GS P	Page
<a href="#">DLE ENQ</a>	Real-time request to printer	S·P		328
<a href="#">DLE DC4</a>	Outputting specified pulse in real-time/Buffer clear	S·P		329/330
<a href="#">ESC =</a>	Data input control	S·P		331
<a href="#">ESC @</a>	Initializing the printer	S·P		332
<a href="#">ESC L</a>	Selecting PAGE MODE	S		333
<a href="#">ESC S</a>	Selecting STANDARD MODE	P		334
<a href="#">ESC p</a>	Generating the specified pulses	S·P		335
<a href="#">GS ( A</a>	Execution of test printing	S		336
<a href="#">GS I</a>	Sending the printer ID	S·P		337
<a href="#">GS P</a>	Specifying the basic calculation pitch	S·P		348
<a href="#">ESC RS</a>	Sound buzzer	S·P		349

In the Mode column: S = STANDARD MODE, P = PAGE MODE  
O = shows the command affected by GS P.

## 2.1.9 BD2-2220

### Print Control Commands

Command	Function	MODE	GS P	Page
<a href="#">LF</a>	Printing and paper feed	S-P		53
<a href="#">CR</a>	Back to printing	S-P		54
<a href="#">FF</a>	Printing in PAGE MODE and returning to STANDARD MODE (at the selection of PAGE MODE)	P		55
<a href="#">ESC FF</a>	Printing data in PAGE MODE	P		56
<a href="#">ESC J</a>	Printing and feeding paper in minimum pitch	S-P	○	57
<a href="#">ESC d</a>	Printing and feeding the paper by "n" lines	S-P		58

### Print Character Commands

Command	Function	MODE	GS P	Page
<a href="#">CAN</a>	Canceling print data in PAGE MODE	P		59
<a href="#">ESC SP</a>	Setting the right spacing of the character	S-P	○	60
<a href="#">ESC !</a>	Collectively specifying the printing mode	S-P		61
<a href="#">ESC %</a>	Specifying/Canceling download character set	S-P		63
<a href="#">ESC &amp;</a>	Defining the download characters	S-P		64
<a href="#">ESC -</a>	Specifying/canceling underline	S-P		66
<a href="#">ESC ?</a>	Deleting download characters	S-P		67
<a href="#">ESC E</a>	Specifying/canceling emphasis printing	S-P		68
<a href="#">ESC G</a>	Specifying/canceling double strike printing	S-P		69
<a href="#">ESC M</a>	Selection of character fonts	S-P		70
<a href="#">ESC R</a>	Selecting the international character set	S-P		71
<a href="#">ESC V</a>	Specifying/canceling 90°-right-turned characters	S		72
<a href="#">ESC t</a>	Selecting the character code table	S-P		73
<a href="#">ESC {</a>	Specifying/canceling the inverted characters	S		74
<a href="#">GS !</a>	Specifying the character size	S-P		80
<a href="#">GS B</a>	Specifying/canceling the black/white inverted printing	S-P		82
<a href="#">GS b</a>	Specifying/canceling the smoothing	S-P		83

### Print Position Commands

Command	Function	MODE	GS P	Page
<a href="#">HT</a>	Horizontal tab	S-P		84
<a href="#">ESC \$</a>	Specifying the absolute positions	S-P	○	85
<a href="#">ESC D</a>	Setting horizontal tab position	S-P		86
<a href="#">ESC T</a>	Selecting the character printing direction in PAGE MODE	P		87
<a href="#">ESC W</a>	Defining the print area in PAGE MODE	P	○	88
<a href="#">ESC \</a>	Specifying the relative position	S-P	○	90
<a href="#">ESC a</a>	Aligning the characters	S		91
<a href="#">GS \$</a>	Specifying the absolute vertical position of characters in PAGE MODE	P	○	92
<a href="#">GS L</a>	Setting the left margin	S	○	93
<a href="#">GS W</a>	Setting the print area width	S-P	○	94
<a href="#">GS \</a>	Specifying the relative vertical position of a character in PAGE MODE	S-P	○	96

### Line Feed Span Commands

Command	Function	MODE	GS P	Page
<a href="#">ESC 2</a>	Specifying initial line feed rate	S-P		97
<a href="#">ESC 3</a>	Setting line feed rate of minimum pitch	S-P	○	98

### Bit Image Commands

Command	Function	MODE	GS P	Page
<a href="#">ESC *</a>	Specifying the bit image mode	S·P		99
<a href="#">GS *</a>	Defining the download bit image	S·P		100
<a href="#">GS /</a>	Printing the downloaded bit image	S·P		101
<a href="#">GS v 0</a>	Printing of raster bit image	S		102

### Status Commands

Command	Function	MODE	GS P	Page
<a href="#">DLE EOT</a>	Sending status in real-time	S·P		104
<a href="#">ESC v</a>	Sending Printer status	S·P		125
<a href="#">GS a</a>	Enabling/disabling ASB (Automatic Status Back)	S·P		126
<a href="#">GS r</a>	Sending status	S·P		130

### Paper Detecting Commands

Command	Function	MODE	GS P	Page
<a href="#">ESC c 3</a>	Selecting the Paper Sensor valid for Paper-end signal output	S·P		132
<a href="#">ESC c 4</a>	Selecting the Paper Near-end Sensor valid for print stop	S·P		133

### Panel Switch Commands

Command	Function	MODE	GS P	Page
<a href="#">ESC c 5</a>	Enabling/disabling the panel switches	S·P		134

### Macro Commands

Command	Function	MODE	GS P	Page
<a href="#">GS :</a>	Starting/ending macro definition	S·P		135
<a href="#">GS ^</a>	Executing the macro	S·P		136

### Cutter Commands

Command	Function	MODE	GS P	Page
<a href="#">ESC i</a>	Full cut	S·P		137
<a href="#">ESC m</a>	Partial cut	S·P		138
<a href="#">GS V</a>	Cutting the paper	S·P	○	139

### Bar Code Commands

Command	Function	MODE	GS P	Page
<a href="#">GS H</a>	Selecting of printing position of HRI characters	S·P		140
<a href="#">GS f</a>	Selecting the font of HRI characters	S·P		141
<a href="#">GS h</a>	Specifying the height of the bar code	S·P		142
<a href="#">GS k</a>	Printing the bar code	S·P		143
<a href="#">GS w</a>	Specifying the horizontal size (magnification) of bar code	S·P		149

### Commands for Non-volatile Memory

Command	Function	MODE	GS P	Page
<a href="#">FS p</a>	Printing the download NV bit images	S		166
<a href="#">FS q</a>	Defining the download NV bit image	S		167

## Kanji Control Commands

Command	Function	MODE	GS P	Page
<a href="#">FS !</a>	Collectively setting Kanji print mode	S-P		169
<a href="#">FS &amp;</a>	Setting Kanji mode	S-P		170
<a href="#">FS -</a>	Setting/Canceling Kanji underline	S-P		171
<a href="#">FS .</a>	Canceling Kanji mode	S-P		172
<a href="#">FS 2</a>	Defining external character	S-P		173
<a href="#">FS C</a>	Selecting Kanji code system	S-P		175
<a href="#">FS S</a>	Setting Kanji space amount	S-P	○	177
<a href="#">FS W</a>	Setting/Canceling four times enlargement of Kanji	S-P		178
<a href="#">FS ( A</a>	Setting font attribute of Kanji	S-P		179

## Printer Function Setting Commands

Command	Function	MODE	GS P	Page
<a href="#">GS ( E</a>	Printer function setting command	S		191
<a href="#">GS ( K</a>	Selecting print control method	S		302
<a href="#">GS ( M</a>	Customizing the printer	S		306

## Other Commands

Command	Function	MODE	GS P	Page
<a href="#">DLE ENQ</a>	Real-time request to printer	S-P		328
<a href="#">DLE DC4</a>	Buffer clear	S-P		330
<a href="#">ESC =</a>	Data input control	S-P		331
<a href="#">ESC @</a>	Initializing the printer	S-P		332
<a href="#">ESC L</a>	Selecting PAGE MODE	S		333
<a href="#">ESC S</a>	Selecting STANDARD MODE	P		334
<a href="#">GS ( A</a>	Execution of test printing	S		336
<a href="#">GS I</a>	Sending the printer ID	S-P		337
<a href="#">GS P</a>	Specifying the basic calculation pitch	S-P		348

In the Mode column: S = STANDARD MODE, P = PAGE MODE  
 O = shows the command affected by GS P.



## 2.1.10 PMU2XXX

### Print Control Commands

Command	Function	MODE	GS P	Page
<a href="#">LF</a>	Printing and paper feed	S-P		53
<a href="#">CR</a>	Back to printing	S-P		54
<a href="#">FF</a>	(1)Printing in PAGE MODE and returning to STANDARD MODE (at the selection of PAGE MODE) (2)Printing of Black mark/Label paper and feeding paper to the top of the print position (with Black mark/Label paper selected)	P		55
<a href="#">ESC FF</a>	Printing data in PAGE MODE	P		56
<a href="#">ESC J</a>	Printing and feeding paper in minimum pitch	S-P	○	57
<a href="#">ESC d</a>	Printing and feeding the paper by "n" lines	S-P		58

### Print Character Commands

Command	Function	MODE	GS P	Page
<a href="#">CAN</a>	Canceling print data in PAGE MODE	P		59
<a href="#">ESC SP</a>	Setting the right spacing of the character	S-P	○	60
<a href="#">ESC !</a>	Collectively specifying the printing mode	S-P		61
<a href="#">ESC %</a>	Specifying/Canceling download character set	S-P		63
<a href="#">ESC &amp;</a>	Defining the download characters	S-P		64
<a href="#">ESC -</a>	Specifying/canceling underline	S-P		66
<a href="#">ESC ?</a>	Deleting download characters	S-P		67
<a href="#">ESC E</a>	Specifying/canceling emphasis printing	S-P		68
<a href="#">ESC G</a>	Specifying/canceling double strike printing	S-P		69
<a href="#">ESC M</a>	Selection of character fonts	S-P		70
<a href="#">ESC R</a>	Selecting the international character set	S-P		71
<a href="#">ESC V</a>	Specifying/canceling 90°-right-turned characters	S		72
<a href="#">ESC t</a>	Selecting the character code table	S-P		73
<a href="#">ESC {</a>	Specifying/canceling the inverted characters	S		74
<a href="#">GS !</a>	Specifying the character size	S-P		80
<a href="#">GS B</a>	Specifying/canceling the black/white inverted printing	S-P		82
<a href="#">GS b</a>	Specifying/canceling the smoothing	S-P		83

### Print Position Commands

Command	Function	MODE	GS P	Page
<a href="#">HT</a>	Horizontal tab	S-P		84
<a href="#">ESC \$</a>	Specifying the absolute positions	S-P	○	85
<a href="#">ESC D</a>	Setting horizontal tab position	S-P		86
<a href="#">ESC T</a>	Selecting the character printing direction in PAGE MODE	P		87
<a href="#">ESC W</a>	Defining the print area in PAGE MODE	P	○	88
<a href="#">ESC \</a>	Specifying the relative position	S-P	○	90
<a href="#">ESC a</a>	Aligning the characters	S		91
<a href="#">GS \$</a>	Specifying the absolute vertical position of characters in PAGE MODE	P	○	92
<a href="#">GS L</a>	Setting the left margin	S	○	93
<a href="#">GS W</a>	Setting the print area width	S-P	○	94
<a href="#">GS \</a>	Specifying the relative vertical position of a character in PAGE MODE	S-P	○	96

### Line Feed Span Commands

Command	Function	MODE	GS P	Page
<a href="#">ESC 2</a>	Specifying initial line feed rate	S·P		97
<a href="#">ESC 3</a>	Setting line feed rate of minimum pitch	S·P	○	98

### Bit Image Commands

Command	Function	MODE	GS P	Page
<a href="#">ESC *</a>	Specifying the bit image mode	S·P		99
<a href="#">GS *</a>	Defining the download bit image	S·P		100
<a href="#">GS /</a>	Printing the downloaded bit image	S·P		101
<a href="#">GS v 0</a>	Printing of raster bit image	S		102

### Status Commands

Command	Function	MODE	GS P	Page
<a href="#">DLE EOT</a>	Sending status in real-time	S·P		104
<a href="#">ESC v</a>	Sending Printer status	S·P		125
<a href="#">GS a</a>	Enabling/disabling ASB (Automatic Status Back)	S·P		126
<a href="#">GS r</a>	Sending status	S·P		130

### Paper Detecting Commands

Command	Function	MODE	GS P	Page
<a href="#">ESC c 3</a>	Selecting the Paper Sensor valid for Paper-end signal output	S·P		132
<a href="#">ESC c 4</a>	Selecting the Paper Near-end Sensor valid for print stop	S·P		133

### Panel Switch Commands

Command	Function	MODE	GS P	Page
<a href="#">ESC c 5</a>	Enabling/disabling the panel switches	S·P		134

### Macro Commands

Command	Function	MODE	GS P	Page
<a href="#">GS :</a>	Starting/ending macro definition	S·P		135
<a href="#">GS ^</a>	Executing the macro	S·P		136

### Cutter Commands

Command	Function	MODE	GS P	Page
<a href="#">ESC i</a>	Full cut	S·P		137
<a href="#">ESC m</a>	Partial cut	S·P		138
<a href="#">GS V</a>	Cutting the paper	S·P	○	139

### Bar Code Commands

Command	Function	MODE	GS P	Page
<a href="#">GS H</a>	Selecting of printing position of HRI characters	S·P		140
<a href="#">GS f</a>	Selecting the font of HRI characters	S·P		141
<a href="#">GS h</a>	Specifying the height of the bar code	S·P		142
<a href="#">GS k</a>	Printing the bar code	S·P		143
<a href="#">GS w</a>	Specifying the horizontal size (magnification) of bar code	S·P		149

### Commands for Non-volatile Memory

Command	Function	MODE	GS P	Page
<a href="#">FS p</a>	Printing the download NV bit images	S		166
<a href="#">FS q</a>	Defining the download NV bit image	S		167

## Kanji Control Commands

Command	Function	MODE	GSP	Page
<a href="#">FS !</a>	Collectively setting Kanji print mode	S-P		169
<a href="#">FS &amp;</a>	Setting Kanji mode	S-P		170
<a href="#">FS -</a>	Setting/Canceling Kanji underline	S-P		171
<a href="#">FS .</a>	Canceling Kanji mode	S-P		172
<a href="#">FS 2</a>	Defining external character	S-P		173
<a href="#">FS C</a>	Selecting Kanji code system	S-P		175
<a href="#">FS S</a>	Setting Kanji space amount	S-P	○	177
<a href="#">FS W</a>	Setting/Canceling four times enlargement of Kanji	S-P		178
<a href="#">FS ( A</a>	Setting font attribute of Kanji	S-P		179

## Black Mark Control Commands

Command	Function	MODE	GSP	Page
<a href="#">GS FF</a>	Printing and ejecting Black mark/Label paper	S-P		180

## Printer Function Setting Commands

Command	Function	MODE	GSP	Page
<a href="#">GS ( E</a>	Printer function setting command	S		191
<a href="#">GS ( K</a>	Selecting print control method	S		302
<a href="#">GS ( M</a>	Customizing the printer	S		306

## Other Commands

Command	Function	MODE	GSP	Page
<a href="#">DLE ENQ</a>	Real-time request to printer	S-P		328
<a href="#">DLE DC4</a>	Buffer clear	S-P		330
<a href="#">ESC =</a>	Data input control	S-P		331
<a href="#">ESC @</a>	Initializing the printer	S-P		332
<a href="#">ESC L</a>	Selecting PAGE MODE	S		333
<a href="#">ESC S</a>	Selecting STANDARD MODE	P		334
<a href="#">GS ( A</a>	Execution of test printing	S		336
<a href="#">GS I</a>	Sending the printer ID	S-P		337
<a href="#">GS P</a>	Specifying the basic calculation pitch	S-P		348

In the Mode column: S = STANDARD MODE, P = PAGE MODE  
 ○ = shows the command affected by GSP.

## 2.1.11 PMU2XXXII

### Print Control Commands

Command	Function	MODE	GS P	Page
<a href="#">LF</a>	Printing and paper feed	S-P		53
<a href="#">CR</a>	Back to printing	S-P		54
<a href="#">FF</a>	(1)Printing in PAGE MODE and returning to STANDARD MODE (at the selection of PAGE MODE) (2)Printing of Black mark/Label paper and feeding paper to the top of the print position (with Black mark/Label paper selected)	P		55
<a href="#">ESC FF</a>	Printing data in PAGE MODE	P		56
<a href="#">ESC J</a>	Printing and feeding paper in minimum pitch	S-P	○	57
<a href="#">ESC d</a>	Printing and feeding the paper by "n" lines	S-P		58

### Print Character Commands

Command	Function	MODE	GS P	Page
<a href="#">CAN</a>	Canceling print data in PAGE MODE	P		59
<a href="#">ESC SP</a>	Setting the right spacing of the character	S-P	○	60
<a href="#">ESC !</a>	Collectively specifying the printing mode	S-P		61
<a href="#">ESC %</a>	Specifying/Canceling download character set	S-P		63
<a href="#">ESC &amp;</a>	Defining the download characters	S-P		64
<a href="#">ESC -</a>	Specifying/canceling underline	S-P		66
<a href="#">ESC ?</a>	Deleting download characters	S-P		67
<a href="#">ESC E</a>	Specifying/canceling emphasis printing	S-P		68
<a href="#">ESC G</a>	Specifying/canceling double strike printing	S-P		69
<a href="#">ESC M</a>	Selection of character fonts	S-P		70
<a href="#">ESC R</a>	Selecting the international character set	S-P		71
<a href="#">ESC V</a>	Specifying/canceling 90°-right-turned characters	S		72
<a href="#">ESC t</a>	Selecting the character code table	S-P		73
<a href="#">ESC {</a>	Specifying/canceling the inverted characters	S		74
<a href="#">GS !</a>	Specifying the character size	S-P		80
<a href="#">GS B</a>	Specifying/canceling the black/white inverted printing	S-P		82
<a href="#">GS b</a>	Specifying/canceling the smoothing	S-P		83

### Print Position Commands

Command	Function	MODE	GS P	Page
<a href="#">HT</a>	Horizontal tab	S-P		84
<a href="#">ESC \$</a>	Specifying the absolute positions	S-P	○	85
<a href="#">ESC D</a>	Setting horizontal tab position	S-P		86
<a href="#">ESC T</a>	Selecting the character printing direction in PAGE MODE	P		87
<a href="#">ESC W</a>	Defining the print area in PAGE MODE	P	○	88
<a href="#">ESC \</a>	Specifying the relative position	S-P	○	90
<a href="#">ESC a</a>	Aligning the characters	S		91
<a href="#">GS \$</a>	Specifying the absolute vertical position of characters in PAGE MODE	P	○	92
<a href="#">GS L</a>	Setting the left margin	S	○	93
<a href="#">GS W</a>	Setting the print area width	S-P	○	94
<a href="#">GS \</a>	Specifying the relative vertical position of a character in PAGE MODE	S-P	○	96

### Line Feed Span Commands

Command	Function	MODE	GS P	Page
<a href="#">ESC 2</a>	Specifying initial line feed rate	S·P		97
<a href="#">ESC 3</a>	Setting line feed rate of minimum pitch	S·P	○	98

### Bit Image Commands

Command	Function	MODE	GS P	Page
<a href="#">ESC *</a>	Specifying the bit image mode	S·P		99
<a href="#">GS *</a>	Defining the download bit image	S·P		100
<a href="#">GS /</a>	Printing the downloaded bit image	S·P		101
<a href="#">GS v 0</a>	Printing of raster bit image	S		102

### Status Commands

Command	Function	MODE	GS P	Page
<a href="#">DLE EOT</a>	Sending status in real-time	S·P		104
<a href="#">ESC v</a>	Sending Printer status	S·P		125
<a href="#">GS a</a>	Enabling/disabling ASB (Automatic Status Back)	S·P		126
<a href="#">GS r</a>	Sending status	S·P		130

### Paper Detecting Commands

Command	Function	MODE	GS P	Page
<a href="#">ESC c 3</a>	Selecting the Paper Sensor valid for Paper-end signal output	S·P		132
<a href="#">ESC c 4</a>	Selecting the Paper Near-end Sensor valid for print stop	S·P		133

### Panel Switch Commands

Command	Function	MODE	GS P	Page
<a href="#">ESC c 5</a>	Enabling/disabling the panel switches	S·P		134

### Macro Commands

Command	Function	MODE	GS P	Page
<a href="#">GS :</a>	Starting/ending macro definition	S·P		135
<a href="#">GS ^</a>	Executing the macro	S·P		136

### Cutter Commands

Command	Function	MODE	GS P	Page
<a href="#">ESC i</a>	Full cut	S·P		137
<a href="#">ESC m</a>	Partial cut	S·P		138
<a href="#">GS V</a>	Cutting the paper	S·P	○	139

### Bar Code Commands

Command	Function	MODE	GS P	Page
<a href="#">GS H</a>	Selecting of printing position of HRI characters	S·P		140
<a href="#">GS f</a>	Selecting the font of HRI characters	S·P		141
<a href="#">GS h</a>	Specifying the height of the bar code	S·P		142
<a href="#">GS k</a>	Printing the bar code	S·P		143
<a href="#">GS w</a>	Specifying the horizontal size (magnification) of bar code	S·P		149

### Commands for Non-volatile Memory

Command	Function	MODE	GS P	Page
<a href="#">FS p</a>	Printing the download NV bit images	S		166
<a href="#">FS q</a>	Defining the download NV bit image	S		167

### Kanji Control Commands

Command	Function	MODE	GS P	Page
<a href="#">FS !</a>	Collectively setting Kanji print mode	S·P		169
<a href="#">FS &amp;</a>	Setting Kanji mode	S·P		170
<a href="#">FS -</a>	Setting/Canceling Kanji underline	S·P		171
<a href="#">FS .</a>	Canceling Kanji mode	S·P		172
<a href="#">FS 2</a>	Defining external character	S·P		173
<a href="#">FS C</a>	Selecting Kanji code system	S·P		175
<a href="#">FS S</a>	Setting Kanji space amount	S·P	○	177
<a href="#">FS W</a>	Setting/Canceling four times enlargement of Kanji	S·P		178
<a href="#">FS ( A</a>	Setting font attribute of Kanji	S·P		179

### Black Mark Control Commands

Command	Function	MODE	GS P	Page
<a href="#">GS FF</a>	Printing and ejecting Black mark/Label paper	S·P		180

### Printer Function Setting Commands

Command	Function	MODE	GS P	Page
<a href="#">GS ( D</a>	Enabling or disabling real-time command	S		191
<a href="#">GS ( E</a>	Printer function setting command	S		191
<a href="#">GS ( K</a>	Selecting print control method	S		302
<a href="#">GS ( M</a>	Customizing the printer	S		306
<a href="#">GS ( N</a>	Designating font attribute	S		309

### 2-dimensional Code Commands

Command	Function	MODE	GS P	Page
<a href="#">GS ( k</a>	Setting and printing 2-dimensional code	S·P		310

### Other Commands

Command	Function	MODE	GS P	Page
<a href="#">DLE ENQ</a>	Real-time request to printer	S·P		328
<a href="#">DLE DC4</a>	Buffer clear	S·P		330
<a href="#">ESC =</a>	Data input control	S·P		331
<a href="#">ESC @</a>	Initializing the printer	S·P		332
<a href="#">ESC L</a>	Selecting PAGE MODE	S		333
<a href="#">ESC S</a>	Selecting STANDARD MODE	P		334
<a href="#">GS ( A</a>	Execution of test printing	S		336
<a href="#">GS I</a>	Sending the printer ID	S·P		337
<a href="#">GS P</a>	Specifying the basic calculation pitch	S·P		348

In the Mode column: S = STANDARD MODE, P = PAGE MODE  
 O = shows the command affected by GS P.

## 2.1.12 PMU2300III

### Print Control Commands

Command	Function	MODE	GS P	Page
<a href="#">LF</a>	Printing and paper feed	S-P		53
<a href="#">CR</a>	Back to printing	S-P		54
<a href="#">FF</a>	(1)Printing in PAGE MODE and returning to STANDARD MODE (at the selection of PAGE MODE) (2)Printing of Black mark/Label paper and feeding paper to the top of the print position (with Black mark/Label paper selected)	P		55
<a href="#">ESC FF</a>	Printing data in PAGE MODE	P		56
<a href="#">ESC J</a>	Printing and feeding paper in minimum pitch	S-P	○	57
<a href="#">ESC d</a>	Printing and feeding the paper by "n" lines	S-P		58

### Print Character Commands

Command	Function	MODE	GS P	Page
<a href="#">CAN</a>	Canceling print data in PAGE MODE	P		59
<a href="#">ESC SP</a>	Setting the right spacing of the character	S-P	○	60
<a href="#">ESC !</a>	Collectively specifying the printing mode	S-P		61
<a href="#">ESC %</a>	Specifying/Canceling download character set	S-P		63
<a href="#">ESC &amp;</a>	Defining the download characters	S-P		64
<a href="#">ESC -</a>	Specifying/canceling underline	S-P		66
<a href="#">ESC ?</a>	Deleting download characters	S-P		67
<a href="#">ESC E</a>	Specifying/canceling emphasis printing	S-P		68
<a href="#">ESC G</a>	Specifying/canceling double strike printing	S-P		69
<a href="#">ESC M</a>	Selection of character fonts	S-P		70
<a href="#">ESC R</a>	Selecting the international character set	S-P		71
<a href="#">ESC V</a>	Specifying/canceling 90°-right-turned characters	S		72
<a href="#">ESC t</a>	Selecting the character code table	S-P		73
<a href="#">ESC {</a>	Specifying/canceling the inverted characters	S		74
<a href="#">GS !</a>	Specifying the character size	S-P		80
<a href="#">GS B</a>	Specifying/canceling the black/white inverted printing	S-P		82
<a href="#">GS b</a>	Specifying/canceling the smoothing	S-P		83

### Print Position Commands

Command	Function	MODE	GS P	Page
<a href="#">HT</a>	Horizontal tab	S-P		84
<a href="#">ESC \$</a>	Specifying the absolute positions	S-P	○	85
<a href="#">ESC D</a>	Setting horizontal tab position	S-P		86
<a href="#">ESC T</a>	Selecting the character printing direction in PAGE MODE	P		87
<a href="#">ESC W</a>	Defining the print area in PAGE MODE	P	○	88
<a href="#">ESC \</a>	Specifying the relative position	S-P	○	90
<a href="#">ESC a</a>	Aligning the characters	S		91
<a href="#">GS \$</a>	Specifying the absolute vertical position of characters in PAGE MODE	P	○	92
<a href="#">GS L</a>	Setting the left margin	S	○	93
<a href="#">GS W</a>	Setting the print area width	S-P	○	94
<a href="#">GS \</a>	Specifying the relative vertical position of a character in PAGE MODE	S-P	○	96

### Line Feed Span Commands

Command	Function	MODE	GS P	Page
<a href="#">ESC 2</a>	Specifying initial line feed rate	S·P		97
<a href="#">ESC 3</a>	Setting line feed rate of minimum pitch	S·P	○	98

### Bit Image Commands

Command	Function	MODE	GS P	Page
<a href="#">ESC *</a>	Specifying the bit image mode	S·P		99
<a href="#">GS *</a>	Defining the download bit image	S·P		100
<a href="#">GS /</a>	Printing the downloaded bit image	S·P		101
<a href="#">GS v 0</a>	Printing of raster bit image	S		102

### Status Commands

Command	Function	MODE	GS P	Page
<a href="#">DLE EOT</a>	Sending status in real-time	S·P		104
<a href="#">ESC v</a>	Sending Printer status	S·P		125
<a href="#">GS a</a>	Enabling/disabling ASB (Automatic Status Back)	S·P		126
<a href="#">GS r</a>	Sending status	S·P		130

### Paper Detecting Commands

Command	Function	MODE	GS P	Page
<a href="#">ESC c 3</a>	Selecting the Paper Sensor valid for Paper-end signal output	S·P		132
<a href="#">ESC c 4</a>	Selecting the Paper Near-end Sensor valid for print stop	S·P		133

### Panel Switch Commands

Command	Function	MODE	GS P	Page
<a href="#">ESC c 5</a>	Enabling/disabling the panel switches	S·P		134

### Macro Commands

Command	Function	MODE	GS P	Page
<a href="#">GS :</a>	Starting/ending macro definition	S·P		135
<a href="#">GS ^</a>	Executing the macro	S·P		136

### Cutter Commands

Command	Function	MODE	GS P	Page
<a href="#">ESC i</a>	Full cut	S·P		137
<a href="#">ESC m</a>	Partial cut	S·P		138
<a href="#">GS V</a>	Cutting the paper	S·P	○	139

### Bar Code Commands

Command	Function	MODE	GS P	Page
<a href="#">GS H</a>	Selecting of printing position of HRI characters	S·P		140
<a href="#">GS f</a>	Selecting the font of HRI characters	S·P		141
<a href="#">GS h</a>	Specifying the height of the bar code	S·P		142
<a href="#">GS k</a>	Printing the bar code	S·P		143
<a href="#">GS w</a>	Specifying the horizontal size (magnification) of bar code	S·P		149

### Commands for Non-volatile Memory

Command	Function	MODE	GS P	Page
<a href="#">FS p</a>	Printing the download NV bit images	S		166
<a href="#">FS q</a>	Defining the download NV bit image	S		167



## Kanji Control Commands

Command	Function	MODE	GS P	Page
<a href="#">FS !</a>	Collectively setting Kanji print mode	S·P		169
<a href="#">FS &amp;</a>	Setting Kanji mode	S·P		170
<a href="#">FS -</a>	Setting/Canceling Kanji underline	S·P		171
<a href="#">FS .</a>	Canceling Kanji mode	S·P		172
<a href="#">FS 2</a>	Defining external character	S·P		173
<a href="#">FS C</a>	Selecting Kanji code system	S·P		175
<a href="#">FS S</a>	Setting Kanji space amount	S·P	○	177
<a href="#">FS W</a>	Setting/Canceling four times enlargement of Kanji	S·P		178
<a href="#">FS ( A</a>	Setting font attribute of Kanji	S·P		179

## Black Mark Control Commands

Command	Function	MODE	GS P	Page
<a href="#">GS FF</a>	Printing and ejecting Black mark/Label paper	S·P		180

## Printer Function Setting Commands

Command	Function	MODE	GS P	Page
<a href="#">GS ( D</a>	Enabling or disabling real-time command	S		191
<a href="#">GS ( E</a>	Printer function setting command	S		191
<a href="#">GS ( K</a>	Selecting print control method	S		302
<a href="#">GS ( M</a>	Customizing the printer	S		306
<a href="#">GS ( N</a>	Designating font attribute	S		309

## 2-dimensional Code Commands

Command	Function	MODE	GS P	Page
<a href="#">GS ( k</a>	Setting and printing 2-dimensional code	S·P		310

## Presenter/Bezel control commands

Command	Function	MODE	GS P	Page
<a href="#">GS R 0</a>	Retracting receipt immediately	S		325
<a href="#">GS R 1</a>	Setting timer for auto receipt retraction	S		325
<a href="#">GS R 2</a>	Controlling bezel LED	S		326
<a href="#">GS S</a>	Detecting next black mark	S		327

## Other Commands

Command	Function	MODE	GS P	Page
<a href="#">DLE ENQ</a>	Real-time request to printer	S·P		328
<a href="#">DLE DC4</a>	Buffer clear	S·P		330
<a href="#">ESC =</a>	Data input control	S·P		331
<a href="#">ESC @</a>	Initializing the printer	S·P		332
<a href="#">ESC L</a>	Selecting PAGE MODE	S		333
<a href="#">ESC S</a>	Selecting STANDARD MODE	P		334
<a href="#">GS ( A</a>	Execution of test printing	S		336
<a href="#">GS I</a>	Sending the printer ID	S·P		337
<a href="#">GS P</a>	Specifying the basic calculation pitch	S·P		348

In the Mode column: S = STANDARD MODE, P = PAGE MODE  
 O = shows the command affected by GS P.

## 2.1.13 CT-P29x series

### Print Control Commands

Command	Function	MODE	GS P	Page
<a href="#">LF</a>	Printing and paper feed	S-P		53
<a href="#">CR</a>	Back to printing	S-P		54
<a href="#">FF</a>	(1)Printing in PAGE MODE and returning to STANDARD MODE (at the selection of PAGE MODE) (2)Printing of Black mark/Label paper and feeding paper to the top of the print position (with Black mark/Label paper selected)	P		55
<a href="#">ESC FF</a>	Printing data in PAGE MODE	P		56
<a href="#">ESC J</a>	Printing and feeding paper in minimum pitch	S-P	○	57
<a href="#">ESC d</a>	Printing and feeding the paper by "n" lines	S-P		58

### Print Character Commands

Command	Function	MODE	GS P	Page
<a href="#">CAN</a>	Canceling print data in PAGE MODE	P		59
<a href="#">ESC SP</a>	Setting the right spacing of the character	S-P	○	60
<a href="#">ESC !</a>	Collectively specifying the printing mode	S-P		61
<a href="#">ESC %</a>	Specifying/Canceling download character set	S-P		63
<a href="#">ESC &amp;</a>	Defining the download characters	S-P		64
<a href="#">ESC -</a>	Specifying/canceling underline	S-P		66
<a href="#">ESC ?</a>	Deleting download characters	S-P		67
<a href="#">ESC E</a>	Specifying/canceling emphasis printing	S-P		68
<a href="#">ESC G</a>	Specifying/canceling double strike printing	S-P		69
<a href="#">ESC M</a>	Selection of character fonts	S-P		70
<a href="#">ESC R</a>	Selecting the international character set	S-P		71
<a href="#">ESC V</a>	Specifying/canceling 90°-right-turned characters	S		72
<a href="#">ESC t</a>	Selecting the character code table	S-P		73
<a href="#">ESC {</a>	Specifying/canceling the inverted characters	S		74
<a href="#">GS !</a>	Specifying the character size	S-P		80
<a href="#">GS B</a>	Specifying/canceling the black/white inverted printing	S-P		82
<a href="#">GS b</a>	Specifying/canceling the smoothing	S-P		83

### Print Position Commands

Command	Function	MODE	GS P	Page
<a href="#">HT</a>	Horizontal tab	S-P		84
<a href="#">ESC \$</a>	Specifying the absolute positions	S-P	○	85
<a href="#">ESC D</a>	Setting horizontal tab position	S-P		86
<a href="#">ESC T</a>	Selecting the character printing direction in PAGE MODE	P		87
<a href="#">ESC W</a>	Defining the print area in PAGE MODE	P	○	88
<a href="#">ESC \</a>	Specifying the relative position	S-P	○	90
<a href="#">ESC a</a>	Aligning the characters	S		91
<a href="#">GS \$</a>	Specifying the absolute vertical position of characters in PAGE MODE	P	○	92
<a href="#">GS L</a>	Setting the left margin	S	○	93
<a href="#">GS W</a>	Setting the print area width	S-P	○	94
<a href="#">GS \</a>	Specifying the relative vertical position of a character in PAGE MODE	S-P	○	96

### Line Feed Span Commands

Command	Function	MODE	GS P	Page
<a href="#">ESC 2</a>	Specifying initial line feed rate	S·P		97
<a href="#">ESC 3</a>	Setting line feed rate of minimum pitch	S·P	○	98

### Bit Image Commands

Command	Function	MODE	GS P	Page
<a href="#">ESC *</a>	Specifying the bit image mode	S·P		99
<a href="#">GS *</a>	Defining the download bit image	S·P		100
<a href="#">GS /</a>	Printing the downloaded bit image	S·P		101
<a href="#">GS v 0</a>	Printing of raster bit image	S		102

### Status Commands

Command	Function	MODE	GS P	Page
<a href="#">DLE EOT</a>	Sending status in real-time	S·P		104
<a href="#">ESC v</a>	Sending Printer status	S·P		125
<a href="#">GS a</a>	Enabling/disabling ASB (Automatic Status Back)	S·P		126
<a href="#">GS r</a>	Sending status	S·P		130

### Paper Detecting Commands

Command	Function	MODE	GS P	Page
<a href="#">ESC c 3</a>	Selecting the Paper Sensor valid for Paper-end signal output	S·P		132
<a href="#">ESC c 4</a>	Selecting the Paper Near-end Sensor valid for print stop	S·P		133

### Panel Switch Commands

Command	Function	MODE	GS P	Page
<a href="#">ESC c 5</a>	Enabling/disabling the panel switches	S·P		134

### Macro Commands

Command	Function	MODE	GS P	Page
<a href="#">GS :</a>	Starting/ending macro definition	S·P		135
<a href="#">GS ^</a>	Executing the macro	S·P		136

### Cutter Commands

Command	Function	MODE	GS P	Page
<a href="#">ESC i</a>	Full cut	S·P		137
<a href="#">ESC m</a>	Partial cut	S·P		138
<a href="#">GS V</a>	Cutting the paper	S·P	○	139

### Bar Code Commands

Command	Function	MODE	GS P	Page
<a href="#">GS H</a>	Selecting of printing position of HRI characters	S·P		140
<a href="#">GS f</a>	Selecting the font of HRI characters	S·P		141
<a href="#">GS h</a>	Specifying the height of the bar code	S·P		142
<a href="#">GS k</a>	Printing the bar code	S·P		143
<a href="#">GS w</a>	Specifying the horizontal size (magnification) of bar code	S·P		149

### Commands for Non-volatile Memory

Command	Function	MODE	GS P	Page
<a href="#">FS p</a>	Printing the download NV bit images	S		166
<a href="#">FS q</a>	Defining the download NV bit image	S		167

## Kanji Control Commands

Command	Function	MODE	GS P	Page
<a href="#">FS !</a>	Collectively setting Kanji print mode	S·P		169
<a href="#">FS &amp;</a>	Setting Kanji mode	S·P		170
<a href="#">FS -</a>	Setting/Canceling Kanji underline	S·P		171
<a href="#">FS .</a>	Canceling Kanji mode	S·P		172
<a href="#">FS 2</a>	Defining external character	S·P		173
<a href="#">FS C</a>	Selecting Kanji code system	S·P		175
<a href="#">FS S</a>	Setting Kanji space amount	S·P	○	177
<a href="#">FS W</a>	Setting/Canceling four times enlargement of Kanji	S·P		178
<a href="#">FS ( A</a>	Setting font attribute of Kanji	S·P		179

## Printer Function Setting Commands

Command	Function	MODE	GS P	Page
<a href="#">GS ( D</a>	Enabling or disabling real-time command	S		191
<a href="#">GS ( E</a>	Printer function setting command	S		191
<a href="#">GS ( K</a>	Selecting print control method	S		302
<a href="#">GS ( M</a>	Customizing the printer	S		306
<a href="#">GS ( N</a>	Designating font attribute	S		309

## 2-dimensional Code Commands

Command	Function	MODE	GS P	Page
<a href="#">GS ( k</a>	Setting and printing 2-dimensional code	S·P		310

## Other Commands

Command	Function	MODE	GS P	Page
<a href="#">DLE ENQ</a>	Real-time request to printer	S·P		328
<a href="#">DLE DC4</a>	Buffer clear	S·P		330
<a href="#">ESC =</a>	Data input control	S·P		331
<a href="#">ESC @</a>	Initializing the printer	S·P		332
<a href="#">ESC L</a>	Selecting PAGE MODE	S		333
<a href="#">ESC S</a>	Selecting STANDARD MODE	P		334
<a href="#">GS ( A</a>	Execution of test printing	S		336
<a href="#">GS I</a>	Sending the printer ID	S·P		337
<a href="#">GS P</a>	Specifying the basic calculation pitch	S·P		348

In the Mode column: S = STANDARD MODE, P = PAGE MODE  
 O = shows the command affected by GS P.

## 2.2 Command Details

### 2.2.1 Description of Items

**XXXX**

<b>support model</b>					
----------------------	--	--	--	--	--

---

**[Function]** The name of a command.

**[Code]** The string of codes comprising the command is represented by < >H for hexadecimal numbers, < >B for binary numbers, and < > for decimal numbers, [ ] k denotes the number of repetition of "k" times.

**[Range]** Indicates the values (setting range) of arguments of the command.

**Note:** If values outside the defined domain specified with control codes are used, malfunctions could possibly occur, so be sure to use the values within the defined domain.

\*The defined domain may differ depending on the model or printer setting.

**[Outline]** **[The specification which is common to the model]**

Indicates command functions common to relevant models.

**[The specification which depend on the model]**

Indicates the command function dependent on the model.

**[Caution]** Describes important points and cautionary notes, as required.

**[Default]** Initial values for the command if it has arguments.

**[See Also]** Describes commands related to the command when it is used.

**[Sample Program]**

Describes examples of coding on Quick-Basic.

\* Examples are only for reference. They may vary depending on language and version. For details, please refer to a manual in your language.

**[Print Results]**

Describes the print results obtained by executing the above programs. However, the print results shown are different in scale from actual print results

## 2.2.2 Print Control Commands

# LF

Support model	CT-S280	CT-S300	CT-S2000	CT-S4000	BD2-2220	PMU series
	CT-S281	CT-S310	CT-S801/851	CT-S601/651	CT-P29x series	CT-S310II

**[Function]**      Printing and paper feed

**[Code]**            <0A>H

**[Outline]**            **[The specification which is common to the model]**  
 • Prints data inside the print buffer and feeds paper based on the line feed amount having been set.

**[Caution]**            **[The specification which is common to the model]**  
 • After this command is executed, the beginning of the line is taken as the start position for the next point.

**[See Also]**            [ESC 2](#), [ESC 3](#)

**[Sample Program]**

```
LPRINT "AAA"; CHR$(&HA);
LPRINT "BBB"; CHR$(&HA); CHR$(&HA);
LPRINT "CCC"; CHR$(&HA);
```

**[Print Results]**

```
AAA      ←      Print and line feed
BBB      ←      Print and line feed
         ←      Line feed only
CCC      ←      Print and line feed
```

# CR

Support model	CT-S280	CT-S300	CT-S2000	CT-S4000	BD2-2220	PMU series
	CT-S281	CT-S310	CT-S801/851	CT-S601/651	CT-P29x series	CT-S310II

**[Function]** Back to printing

**[Code]** <0D>H

**[Outline]** **[The specification which is common to the model]**

(1) MSW\* 1-5 OFF:

This command is ignored.

(2) MSW 1-5 ON:

The same operation as LF is executed.

\* Memory switch

**[See Also]** [LF](#)

**[Sample Program]**

```
LPRINT "AAA"; CHR$(&HD);  
LPRINT "BBB"; CHR$(&HD);  
LPRINT CHR$(&HD);  
LPRINT "CCC"; CHR$(&HD);
```

**[Print Results]**

In case of (2)

```
AAA ← Print and line feed  
BBB ← Print and line feed  
← Line feed only  
CCC ← Print and line feed
```

# FF (At selection of PAGE MODE)

Support model	CT-S280	CT-S300	CT-S2000	CT-S4000	BD2-2220	PMU series
	CT-S281	CT-S310	CT-S801/851	CT-S601/651	CT-P29x series	CT-S310II

- [Function]** Printing in PAGE MODE and returning to STANDARD MODE (at the selection of PAGE MODE)
- [Code]** <0C>H
- [Outline]** **[The specification which is common to the model]**
- Executes a batch printout of the data mapped in the entire print area, and then returns to STANDARD MODE.
- [Caution]** **[The specification which is common to the model]**
- All mapped data is erased after printout.
  - The print area set up by ESC W is initialized.
  - This command does not execute a paper cut.
  - After this command is executed, the beginning of the line is taken as the start position for the next print.
  - This command is only effective when the PAGE MODE is selected.

## CT-S4000

- When selecting BM paper or label paper to specify the PAGE MODE, data extended to all printing area is printed in batch. After returning to the STANDARD MODE, setting the start position of next label is carried out.

- [See Also]** Appendix 5.1.4 "Example of Using PAGE MODE"  
[ESC FF](#), [ESCL](#), [ESCS](#)

# FF (valid only for Black mark/Label specification)

Support model	CT-S280	CT-S300	CT-S2000	CT-S4000	BD2-2220	PMU series
	CT-S281	CT-S310	CT-S801/851	CT-S601/651	CT-P29x series	CT-S310II

- [Function]** At selection of Black mark/Label paper (valid only for Black mark/Label specification)
- [Outline]** **[The specification which is common to the model]**
- This command prints the data in the printer buffer and searches for the head of the next Black mark/Label (Black mark position/Top of label)
- [Caution]** **[The specification which is common to the model]**
- This command does not execute a paper cut.
  - After this command is executed, the beginning of the line is taken as the start position for the next print.
  - Valid only for label- or BM-supported model.  
 (Please confirm specifications for the details.)
- [See Also]** [GS FF](#)



# ESC FF

Support model	CT-S280	CT-S300	CT-S2000	CT-S4000	BD2-2220	PMU series
	CT-S281	CT-S310	CT-S801/851	CT-S601/651	CT-P29x series	CT-S310II

**[Function]** Printing data in PAGE MODE

**[Code]** <1B>H<0C>H

**[Outline]** **[The specification which is common to the model]**  
• Executes a batch printout of the data mapped in the entire print area in PAGE MODE.

**[Caution]** **[The specification which is common to the model]**  
• This command is only effective when PAGE MODE is selected.  
• Mapped data, as well as the ESC T and ESC W settings, and the character mapping position are held even after printing.

**[See Also]** Appendix 5.1 "Explanation on PAGE MODE"  
[FF](#), [ESCL](#), [ESCS](#)

# ESC J n

Support model	CT-S280	CT-S300	CT-S2000	CT-S4000	BD2-2220	PMU series
	CT-S281	CT-S310	CT-S801/851	CT-S601/651	CT-P29x series	CT-S310II

**[Function]** Printing and feeding paper in minimum pitch

**[Code]** <1B>H<4A>H<n>

**[Range]**  $0 \leq n \leq 255$

**[Outline]** **[The specification which is common to the model]**  
• Prints the data held in the print buffer and feeds paper by  $[n \times \text{basic calculation pitch}]$  inches.

**[Caution]** **[The specification which is common to the model]**

- After this command is executed, the beginning of the line is taken as the start position for the next print.
- The line feed width can be set separately for the STANDARD and PAGE MODES.
- This command does not affect the line feed width defined by ESC 2 or ESC 3.
- The basic calculation pitch is set by GS P.
- Fractions resulting from calculation are corrected with the minimum pitch of the mechanism, and the remainder is omitted.
- In STANDARD MODE, this command uses the vertical (paper feed direction) basic calculation pitch (y).
- In PAGE MODE, this command acts differently depending on the start point:
  - (1) If the start point specified by ESC T is top left or bottom right, the command uses the vertical (Paper feed direction) basic calculation pitch (y).
  - (2) If the start point specified by ESC T is top right or bottom left, the command uses the horizontal (Perpendicular to the paper feed direction) basic calculation pitch (x).
- The maximum settable line feed width is 1016 mm (40 inches). A setting greater than this maximum is trimmed to the maximum.

**[Default]** The initial value is not defined.

# ESC d n

Support model	CT-S280	CT-S300	CT-S2000	CT-S4000	BD2-2220	PMU series
	CT-S281	CT-S310	CT-S801/851	CT-S601/651	CT-P29x series	CT-S310 II

**[Function]** Printing and feeding the paper by "n" lines

**[Code]** <1B>H<64>H<n>

**[Range]** 0≤n≤255

**[Outline]** **[The specification which is common to the model]**  
Prints data in the print buffer and feeds paper by "n" lines. Specified lines do not remain.

**[Caution]**

- After this command is executed, the beginning of the line is taken as the start position for the next print.
- If [n×line feed width] exceeds approximately 1016 mm, this command feeds paper by approximately 1016 mm (40 inches).

**[Default]** The initial value is not defined.

**[Sample Program]**

```
LPRINT "AAAAA";
LPRINT CHR$(&H1B);"d";CHR$(2);
LPRINT "AAAAA";CHR$(&HA);
```

**[Print Results]**

```
AAAAA
      |
      | 2/6-inch line feed
      |
AAAAA
```

## 2.2.3 Print Character Commands

# CAN

Support model	CT-S280	CT-S300	CT-S2000	CT-S4000	BD2-2220	PMU series
	CT-S281	CT-S310	CT-S801/851	CT-S601/651	CT-P29x series	CT-S310 II

**[Function]** Canceling print data in PAGE MODE

**[Code]** <18>H

**[Outline]** **[The specification which is common to the model]**  
Erases all data contained in the currently effective print area in PAGE MODE.

**[Caution]**

- This command is only effective when PAGE MODE is selected.
- If the previously established print area overlaps the currently effective print area, the overlapped data in the previously established area will be erased.

**[See Also]** Appendix 5.1 "Explanation on PAGE MODE"  
[ESCL](#), [ESC W](#)

# ESC SP n

Support model	CT-S280	CT-S300	CT-S2000	CT-S4000	BD2-2220	PMU series
	CT-S281	CT-S310	CT-S801/851	CT-S601/651	CT-P29x series	CT-S310 II

**[Function]**      Setting the right spacing of the character

**[Code]**            <1B>H<20>H<n>

**[Range]**            0≤n≤255

**[Outline]**            **[The specification which is common to the model]**  
 • Sets the right spacing of character to [n×basic calculation pitch] inches.

**[Caution]**            **[The specification which is common to the model]**

- If the horizontal magnification of character is 2 or more, the right spacing increases with the magnification.
- Does not affect Kanji.
- The right spacing can be set separately for the STANDARD and PAGE MODES.
- The basic calculation pitch is set by GS P. Once defined, the right spacing is not changed if the basic calculation pitch is changed by GS P.
- Fractions resulting from calculation are corrected with the minimum pitch of the mechanism, and the remainder is omitted.
- In STANDARD MODE, this command uses the horizontal basic calculation pitch (x).
- In PAGE MODE, the basic calculation pitch used by this command depends on the start point:
  - (1) If the start point specified by ESC T is top left or bottom right, the command uses the horizontal basic calculation pitch (x).
  - (2) If the start point specified by ESC T is top right or bottom left, the command uses the vertical basic calculation pitch (y).
- The maximum right spacing is capable of approximately 31.906 mm (255/203 inches). A setting greater than this maximum is trimmed to the maximum.

**[Default]**            n=0

**[The specification which depend on the model]**

**CT-S801/CT-S851/CT-S601/CT-S651**

MSW6-2 ON : n=0

MSW6-2 OFF: n=1

**[See Also]**         [GSP](#)

**[Sample Program]**

```
LPRINT CHR$(&H1B);" "; CHR$(0);
LPRINT "AAAAA"; CHR$(&HA);
LPRINT CHR$(&H1B);" "; CHR$(1);
LPRINT "AAAAA"; CHR$(&HA);
LPRINT CHR$(&H1B);" "; CHR$(12);
LPRINT "AAAAA"; CHR$(&HA);
```

**[Print Results]**

```
A A A A A            ← 0-dot space
A A A A A            ← 1-dot space
A A A A A            ← 12-dots space
```

# ESC ! n

Support model	CT-S280	CT-S300	CT-S2000	CT-S4000	BD2-2220	PMU series
	CT-S281	CT-S310	CT-S801/851	CT-S601/651	CT-P29x series	CT-S310 II

**[Function]** Collectively specifying the printing mode

**[Code]** <1B>H<21>H<n>

**[Range]** 0≤n≤255

**[Outline]** **[The specification which is common to the model]**  
Printing mode is assigned.

**[The specification which depend on the model]**

**CT-S300/CT-S310/CT-S801/CT-S851/CT-S601/CT-S651/CT-P29xseries**

Bit	Function	Value	
		0	1
0	Character Font	Font A (12×24)	Font B (9×17)
1	Undefined	—	—
2	Undefined	—	—
3	Emphasis	Canceled	Specified
4	Double height	Canceled	Specified
5	Double width	Canceled	Specified
6	Undefined	—	—
7	Underline	Canceled	Specified

**CT-S280/CT-S281/CT-S2000/CT-S4000/BD2-2220/PMU series/CT-S310 II**

Bit	Function	Value	
		0	1
0	Character Font	Font A (12×24)	Font B (9×24)
1	Undefined	—	—
2	Undefined	—	—
3	Emphasis	Canceled	Specified
4	Double height	Canceled	Specified
5	Double width	Canceled	Specified
6	Undefined	—	—
7	Underline	Canceled	Specified

**[Caution]**

- With double height and double width being specified simultaneously, quadruple characters are created.
- An underline is attached to the full character width, which, however, is not attached to the part having been skipped by the horizontal tab (HT). Neither is it attached to 90°-right-turned characters.
- The underline width is as specified by the ESC – command. (The default setting is 1 dot width.)
- Setting by this command is invalid for Kanji except setting and canceling of enhanced printing.
- In case characters with different vertical magnification ratios coexist on the same line, they are printed on the same base line.
- ESC E, ESC M, ESC –, and GS ! can individually set or cancel the mode but the command processed last is valid.
- Setting or canceling of enhanced 3rd bit is valid for alphanumeric and kana and kanji. Other print mode is valid only for alphanumeric and kana characters.
- Setting memory SW 3-7 to ON allows the horizontal and vertical relations to be interchanged when 90°-right-turning of character is specified.

**[Default]** n=0

**[See Also]** [ESC E](#), [ESC -](#), [GS !](#)

**[Sample Program]**

```
LPRINT CHR$(&H1B);"!"; CHR$(&H00);"H";  
LPRINT CHR$(&H1B);"!"; CHR$(&H01);"H";  
LPRINT CHR$(&H1B);"!"; CHR$(&H08);"H";  
LPRINT CHR$(&H1B);"!"; CHR$(&H10);"H";  
LPRINT CHR$(&H1B);"!"; CHR$(&H20);"H";  
LPRINT CHR$(&H1B);"!"; CHR$(&H80);"H";  
LPRINT CHR$(&H1B);"!"; CHR$(&HB9);"H";  
LPRINT CHR$(&HA);
```

**[Print Results]**

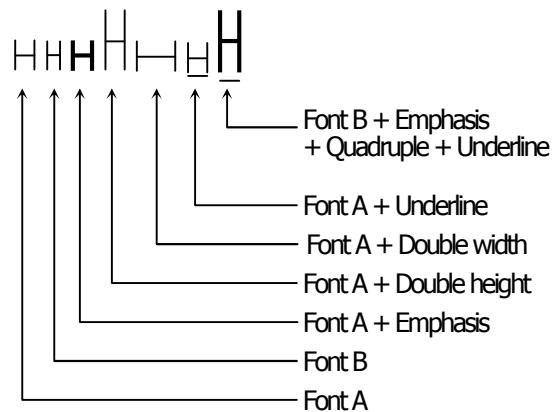

# ESC % n

Support model	CT-S280	CT-S300	CT-S2000	CT-S4000	BD2-2220	PMU series
	CT-S281	CT-S310	CT-S801/851	CT-S601/651	CT-P29x series	CT-S310 II

**[Function]** Specifying/canceling download character set

**[Code]** <1B>H<25>H<n>

**[Range]** 0≤n≤255

**[Outline]** **[The specification which is common to the model]**

Specifying/canceling download characters.

- "n" is valid only for the lowest bit (n0).
- Control by the lowest bit (n0) is shown as follows:

n0	Function
0	Canceling download character set
1	Specifying download character set

**[Default]** n=0

**[See Also]** [ESC &](#)

**[Sample Program]**

```

GOSUB SETCHR                                DATA 6
LPRINT CHR$(&H1B);"%";CHR$(0);             DATA &HFF,&H80,&H00
LPRINT "@A";CHR$(&HA);                      DATA &H80,&H80,&H00
LPRINT CHR$(&H1B);"%";CHR$(1);             DATA &H80,&H80,&H00
LPRINT "@A";CHR$(&HA);                      DATA &H80,&H80,&H00
END                                           DATA &HFF,&HFF,&HFF
SETCHR:                                       DATA &HFF,&HFF,&HFF
LPRINT CHR$(&H1B);"&";                       DATA 12
LPRINT CHR$(3);"@";"A";                     DATA &HFF,&HFF,&HFF
FOR J=1 TO 2                                  DATA &H80,&H07,&HF9
  READ REP                                     DATA &H80,&HFF,&HF9
  LPRINT CHR$(REP);                           DATA &H87,&HFE,&H01
  FOR I=1 TO REP*3                             DATA &H9F,&H06,&H01
    READ D                                       DATA &HF8,&H06,&H01
    LPRINT CHR$(D);                             DATA &HF8,&H06,&H01
  NEXT I                                       DATA &H9F,&H06,&H01
NEXT J                                         DATA &H87,&HFE,&H01
RETURN                                        DATA &H80,&HFF,&HF9
                                              DATA &H80,&H07,&HF9
                                              DATA &HFF,&HFF,&HFF

```

**[Print Results]**

@ A ← Internal character set  
 □ A ← Download character



# ESC & s n m [ a [ p ] s x a ] m-n+1

Support model	CT-S280	CT-S300	CT-S2000	CT-S4000	BD2-2220	PMU series
	CT-S281	CT-S310	CT-S801/851	CT-S601/651	CT-P29x series	CT-S310 II

**[Function]** Defining the download characters

**[Code]** <1B>H<26>H<s>H<n>H<m>H[<a>H<p1>H<p2>—<psxa>] m-n+1

**[Range]** s=3(Font A, B), s=2(Font C)  
 $32 \leq n \leq m \leq 126$   
 $0 \leq a \leq 12$ (Font A)  
 $0 \leq a \leq 9$ (Font B)  
 $0 \leq a \leq 8$ (Font C)  
 $0 \leq p1 - ps \times a \leq 255$

**[Outline]** **[The specification which is common to the model]**

- Defines the font of download characters of alphanumeric characters.
- "s" indicates the number of bytes in vertical direction.
- "n" indicates the start character code and "m" the end character code. To define only one character, set n = m.
- Character codes definable includes 95 ASCII codes in total in the range of 20H to 7EH.
- "a" indicates the number of dots to be defined in horizontal direction.
- "p" is the data to be defined, which indicate a pattern equal to "a" dots in horizontal direction from the left end. The rest of the pattern on the right side is filled with space.
- The number of data to be defined is "s × a".
- Download characters thus defined remain valid until redefinition, execution of ESC @, GS \*, FS q, GS (A, deletion by ESC ?, or power OFF is performed.

**[Caution]** **[The specification which depend on the model]**  
**CT-S280/CT-S281/CT-S300/CT-S310/BD2-2220/PMU series**  
**CT-P29x series**

- Running this command clears the definition of the download bit image.
- **CT-S2000/CT-S4000 /CT-S801/CT-S851/CT-S601/CT-S651**
- Running this command doesn't clear the definition of the download bit image.

**[Default]** Same as the internal character set.

**[See Also]** [ESC %](#), [ESC ?](#)

**[Example]**

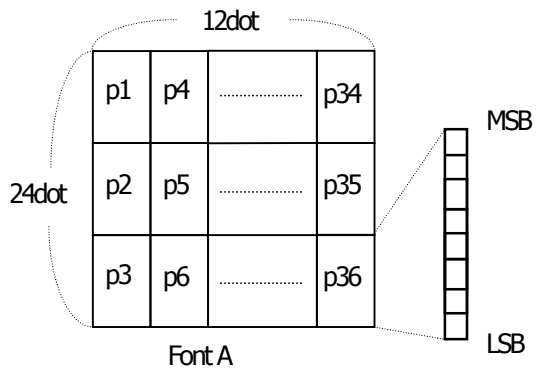

Create each data bit by setting "1" for a printed dot and "0" for an unprinted dot.

**[Sample Program]**

[Refer to Sample Program and Print Results for ESC %.](#)

# ESC - n

Support model	CT-S280	CT-S300	CT-S2000	CT-S4000	BD2-2220	PMU series
	CT-S281	CT-S310	CT-S801/851	CT-S601/651	CT-P29x series	CT-S310 II

**[Function]** Specifying /canceling underline

**[Code]** <1B>H<2D>H<n>

**[Range]** 0≤n≤2, 48≤n≤50

**[Outline]** **[The specification which is common to the model]**

- Specifying /canceling an underline.

n	Function
0,48	Canceling underline
1,49	Setting 1-dot width underline
2,50	Setting 2-dot width underline

**[Caution]** **[The specification which is common to the model]**

- An underline is attached to the full character width. It is, however, not attached to the part having been skipped by horizontal tab (HT) command.
- An underline is not attached to 90°-right-turned characters and white-on-black character.
- Underline can also be specified/canceled by ESC ! but the setting of command last processed is valid.
- Specifying/canceling by this command is not valid for kanji.
- Underline width is constant in the specified thickness regardless of the character size.

**[Default]** n=0

**[See Also]** [ESC!](#), [FS-](#)

**[Sample Program]**

```
LPRINT CHR$(&H1B);"-"; CHR$(0);
LPRINT "AAAAA";
LPRINT CHR$(&H1B);"-"; CHR$(1);
LPRINT "AAAAA"; CHR$(&HA);
```

**[Print Results]**

Underline canceled

←→  
A A A A A A A A A A  
←→

Underline specified

# ESC ? n

Support model	CT-S280	CT-S300	CT-S2000	CT-S4000	BD2-2220	PMU series
	CT-S281	CT-S310	CT-S801/851	CT-S601/651	CT-P29x series	CT-S310 II

**[Function]** Deleting download characters

**[Code]** <1B>H<3F>H<n>

**[Range]** 32≤n≤126

**[Outline]** **[The specification which is common to the model]**

Deletes the downloaded characters of specified code.

**[Caution]** **[The specification which is common to the model]**

- The character "n" indicates the character code used to delete the defined pattern. After the deletion, characters are printed in the same pattern as the internal characters.
- This command deletes the code-defined pattern of the character font selected by ESC !.
- This command is ignored if the specified character code is undefined.

**[See Also]** [ESC &](#), [ESC %](#)

# ESC E n

Support model	CT-S280	CT-S300	CT-S2000	CT-S4000	BD2-2220	PMU series
	CT-S281	CT-S310	CT-S801/851	CT-S601/651	CT-P29x series	CT-S310 II

**[Function]** Specifying/canceling emphasis printing

**[Code]** <1B>H<45>H<n>

**[Range]** 0≤n≤255

**[Outline]** **[The specification which is common to the model]**

- Specifying/canceling the emphasized characters.
- "n" is valid only for the lowest bit (n0).
- Control by the lowest bit (n0) is shown as follows:

n0	Function
0	Canceling emphasis printing
1	Specifying emphasis printing

**[Caution]** **[The specification which is common to the model]**

- Emphasis printing can also be specified/canceled by ESC ! but the setting of command last processed is valid.
- Valid for all character types except HRI characters.

**[Default]** n=0

**[See Also]** [ESC!](#)

**[Sample Program]**

```
LPRINT CHR$(&H1B);"E"; CHR$(0);
LPRINT "AAABBB"; CHR$(&HA);
LPRINT CHR$(&H1B);"E"; CHR$(1);
LPRINT "AAABBB"; CHR$(&HA);
```

**[Print Results]**

```
AAABBB ← Emphasis canceled
AAABBB ← Emphasis specified
```

# ESC G n

Support model	CT-S280	CT-S300	CT-S2000	CT-S4000	BD2-2220	PMU series
	CT-S281	CT-S310	CT-S801/851	CT-S601/651	CT-P29x series	CT-S310 II

**[Function]** Specifying/canceling double strike printing

**[Code]** <1B>H<47>H<n>

**[Range]** 0≤n≤255

**[Outline]** **[The specification which is common to the model]**

- Specifying /canceling the double strike printing.
- "n" is valid only for the lowest bit (n0).
- Control by the lowest bit (n0) is shown as follows:

n0	Function
0	Canceling double strike printing
1	Specifying double strike printing

**[Caution]** **[The specification which is common to the model]**

- With this printer, double-strike printing and emphasis printing provide completely the same results.
- Valid for all character types except HRI characters.

**[Default]** n=0

**[See Also]** [ESC E](#)

**[Sample Program]**

```
LPRINT CHR$(&H1B);"G"; CHR$(0);
LPRINT "AAABBB"; CHR$(&HA);
LPRINT CHR$(&H1B);"G"; CHR$(1);
LPRINT "AAABBB"; CHR$(&HA);
```

**[Print Results]**

```
AAABBB ← Double strike printing canceled
AAABBB ← Double strike printing specified
```

# ESC M n

Support model	CT-S280	CT-S300	CT-S2000	CT-S4000	BD2-2220	PMU series
	CT-S281	CT-S310	CT-S801/851	CT-S601/651	CT-P29x series	CT-S310 II

**[Function]** Selection of character fonts

**[Code]** <1B>H<4D>H<n>

**[Range]** 0≤n≤2, 48≤n≤50

**[Outline]** **[The specification which is common to the model]**

- Selects character fonts.

**[The specification which depend on the model]**

**CT-S300/CT-S310/CT-S801/CT-S851/CT-S601/CT-S651/CT-P29x series**

n	Function
0, 48	Selection of font A (12 × 24)
1, 49	Selection of font B (9 × 17)
2, 50	Selection of font C (8 × 16)

**CT-S280/CT-S281/CT-S2000/CT-S4000/BD2-2220/PMU series/CT-S310 II**

n	Function
0, 48	Selection of font A (12 × 24)
1, 49	Selection of font B (9 × 24)
2, 50	Selection of font C (8 × 16)

**[Caution]** • ESC ! can also select fonts, but the setting made by the command that has last been processed becomes valid.

**[Default]** n=0

**[See Also]** [ESC!](#)

# ESC R n

Support model	CT-S280	CT-S300	CT-S2000	CT-S4000	BD2-2220	PMU series
	CT-S281	CT-S310	CT-S801/851	CT-S601/651	CT-P29x series	CT-S310 II

**[Function]** Selecting the international character set

**[Code]** <1B>H<52>H<n>

**[Range]** **[The specification which depend on the model]**

CT-S280/CT-S300/BD2-2220

0≤n≤13

CT-S281/CT-S310/CT-S2000/CT-S4000

CT-S801/CT-S851/CT-S601/CT-S651/PMU series/CT-P29x series/CT-S310 II

0≤n≤15

**[Outline]** **[The specification which is common to the model]**

- Depending on the value of "n", one of the following character sets is specified;

n	Character Set	n	Character Set
0	U.S.A.	8	Japan
1	France	9	Norway
2	Germany	10	Denmark II
3	U.K.	11	Spain II
4	Denmark I	12	Latin America
5	Sweden	13	Korea
6	Italy	14	Croatia
7	Spain I	15	China

**[Default]** **[The specification which is common to the model]**

standard specifications:

n=0 (International), n=8 (Japan)

Hangul specifications:

n=13

**[The specification which depend on the model]**

Chinese specifications:

CT-S300/CT-S310 (U.S.A)

n=0

CT-S310 (Australia)/CT-S2000/CT-S4000/CT-S801/CT-S851

CT-S601/CT-S651/CT-S310 II

n=15

**[See Also]** [3.2 "International Character Code Table"](#)



# ESC V n

Support model	CT-S280	CT-S300	CT-S2000	CT-S4000	BD2-2220	PMU series
	CT-S281	CT-S310	CT-S801/851	CT-S601/651	CT-P29x series	CT-S310 II

**[Function]** Specifying/canceling 90°-right-turned characters

**[Code]** <1B>H<56>H<n>

**[Range]** 0≤n≤1, 48≤n≤49

**[Outline]** **[The specification which is common to the model]**

- Specifying/canceling 90°-right-turned characters.

n	Function
0,48	Canceling 90°-right-turned characters
1,49	Specifying 90°-right-turned characters

**[Caution]** **[The specification which is common to the model]**

- No underlines are attached to 90°-right-turned characters.
- This command does not affect PAGE MODE but setting is maintained.

**[Default]** n=0

**[Sample Program]**

```
LPRINT CHR$(&H1B);"V"; CHR$(0);
LPRINT "AAAAA";
LPRINT CHR$(&H1B);"V"; CHR$(1);
LPRINT "AAAAA"; CHR$(&HA);
```

**[Print Results]**

# ESC t n

Support model	CT-S280	CT-S300	CT-S2000	CT-S4000	BD2-2220	PMU series
	CT-S281	CT-S310	CT-S801/851	CT-S601/651	CT-P29x series	CT-S310 II

**[Function]** Selecting the character code table

**[Code]** <1B>H<74>H<n>

**[Range]** 0≤n≤9, 16≤n≤19, n=26, 40, 255

**[Outline]** **[The specification which is common to the model]**

- Selecting the character code table.
- The character code table is selected based on the value of "n".

n	Character Code Table	n	Character Code Table
0	Codepage PC437	7,17	Codepage PC866
1	Katakana	8	Codepage PC857
2	Codepage PC850	9,16	Windows code
3	Codepage PC860	19	Codepage PC858
4	Codepage PC863	26	Thai code 18
5	Codepage PC865	40	Codepage PC864
6,18	Codepage PC852	255	Space page (For user setting)

**[Default]** n=0 (International)  
n=1 (Japan)

## [Sample Program]

```
LPRINT CHR$(&H1B);"t"; CHR$(0);
LPRINT "n=0 ";
FOR C=&HB1 TO &HB5
    LPRINT CHR$(C);
NEXT C
LPRINT CHR$(&HA);
LPRINT CHR$(&H1B);"t"; CHR$(1);
LPRINT "n=1 ";
FOR C=&HB1 TO &HB5
    LPRINT CHR$(C);
NEXT C
LPRINT CHR$(&HA);
```

## [Print Results]

n=0 ㄗ ㄘ ㄙ ㄚ ㄛ

n=1 ア イ ウ エ オ

# ESC { n

Support model	CT-S280	CT-S300	CT-S2000	CT-S4000	BD2-2220	PMU series
	CT-S281	CT-S310	CT-S801/851	CT-S601/651	CT-P29x series	CT-S310 II

**[Function]** Specifying/canceling the inverted characters

**[Code]** <1B>H<7B>H<n>

**[Range]** 0≤n≤255

**[Outline]** **[The specification which is common to the model]**

- "n" is valid only for the lowest bit (n0).
- Rotate data in the line by 180 degrees and print it.
- Control by the lowest bit (n0) is shown as follows:

n0	Function
0	Canceling inverted characters.
1	Specifying inverted characters.

**[Caution]** **[The specification which is common to the model]**

- This command is valid only when it is specified at the beginning of a line.
- This command does not affect the PAGE MODE.

**[Default]** n=0

**[Sample Program]**

```
LPRINT CHR$(&H1B);"{"; CHR$(0);
LPRINT "TEN"; CHR$(&HA);
LPRINT "ELEVEN"; CHR$(&HA);
LPRINT CHR$(&H1B);"{"; CHR$(1);
LPRINT "TEN"; CHR$(&HA);
LPRINT "ELEVEN"; CHR$(&HA);
```

**[Print Results]**

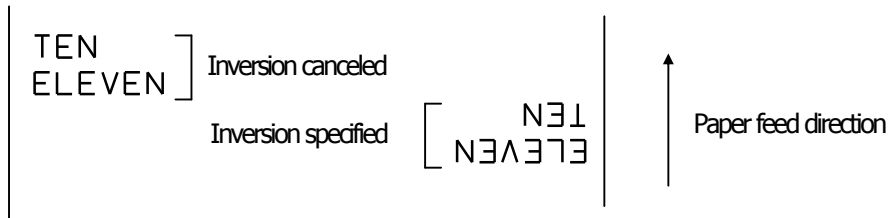

# ESC ~ J n (Valid in CBM-270-Compatible Mode)

Support model	CT-S280	CT-S300	CT-S2000	CT-S4000	BD2-2220	PMU series
	CT-S281	CT-S310	CT-S801/851	CT-S601/651	CT-P29x series	CT-S310 II

**[Function]** Specifies/cancels printing in red (black-based paper)

**[Code]** <1B>H<7E>H<4A>H<n>

**[Range]** 0≤n≤255

**[Outline]** **[The specification which is common to the model]**

- Specifies or cancels printing in red.
- Red printing is valid on black-based thermal paper. Specifies or cancels printing in black on red-based thermal paper.
- "n" is valid only for the lowest bit (n0).
- Control by the lowest bit (n0) is shown as follows:

n0	Function	
	black-based paper	red-based paper
0	Canceling red printing.	Canceling black printing.
1	Specifying red printing.	Specifying black printing.

**[Caution]** **[The specification which is common to the model]**

- Valid when 2-color paper is specified by the GS ( E command).
- This command must not be used for normal thermal paper.
- At the time of setting, conducting pulse amount is increased to change the coloring.
- In case of MSW3-7=OFF, this command is invalid.

**[Default]** n=0

**[Sample Program]**

```
LPRINT CHR$(&H1B);" ~";"J"; CHR$(1);
LPRINT "AAAAA"; CHR$(&HA);
LPRINT CHR$(&H1B);" ~";"J"; CHR$(0);
LPRINT "AAAAA"; CHR$(&HA);
```

**[Print Results]**

```

A A A A A ← Red printing
A A A A A ← Black printing
```

\* When dedicated thermal paper (black-based paper) is used.

# ESC ~ J n (Valid in CBM1000-Compatible Mode)

Support model	CT-S280	CT-S300	CT-S2000	CT-S4000	BD2-2220	PMU series
	CT-S281	CT-S310	CT-S801/851	CT-S601/651	CT-P29x series	CT-S310 II

**[Function]** Specifies/cancels printing in red (black-based paper)

**[Code]** <1B>H<7E>H<4A>H<n>

**[Range]** 0≤n≤255

**[Outline]** **[The specification which is common to the model]**

- Specifies or cancels printing in red.
- Red printing is valid on black-based thermal paper. Specifies or cancels printing in black on red-based thermal paper.
- "n" is valid only for the lowest bit (n0).
- Control by the lowest bit (n0) is shown as follows:

n0	Function	
	black-based paper	red-based paper
0	Specifying red printing.	Specifying black printing.
1	Canceling red printing.	Canceling black printing.

**[Caution]** **[The specification which is common to the model]**

- Valid when 2-color paper is specified by the GS ( E command).
- This command must not be used for normal thermal paper.
- Conducting pulse amount after cancellation is standard value. At the time of setting, conducting pulse amount is increased to change the coloring.
- In case of MSW3-7=OFF, this command is invalid.

**[Default]** n=0

**[Sample Program]**

```
LPRINT CHR$(&H1B);" ~";"J"; CHR$(1);
LPRINT "AAAAA"; CHR$(&HA);
LPRINT CHR$(&H1B);" ~";"J"; CHR$(0);
LPRINT "AAAAA"; CHR$(&HA);
```

**[Print Results]**

```
A A A A A ← Black printing
A A A A A ← Red printing
```

\* When dedicated thermal paper (black-based paper) is used.

# DC3 n (Valid in CBM-270-Compatible Mode)

Support model	CT-S280	CT-S300	CT-S2000	CT-S4000	BD2-2220	PMU series
	CT-S281	CT-S310	CT-S801/851	CT-S601/651	CT-P29x series	CT-S310 II

**[Function]** Specifies/cancels printing in red (black-based paper)

**[Code]** <13>H<n>

**[Range]** 0≤n≤255

**[Outline]** **[The specification which is common to the model]**

- Specifies or cancels printing in red.
- Red printing is valid on black-based thermal paper. Specifies or cancels printing in black on red-based thermal paper.
- "n" is valid only for the lowest bit (n0).
- Control by the lowest bit (n0) is shown as follows:

n0	Function	
	black-based paper	red-based paper
0	Canceling red printing.	Canceling black printing.
1	Specifying red printing.	Specifying black printing.

**[Caution]** **[The specification which is common to the model]**

- Valid only at the top of a line.
- This command must not be used for normal thermal paper.
- At the time of setting, conducting pulse amount is increased to change the coloring.
- In case of MSW3-7=OFF, this command is invalid.
- Valid only in standard mode.

**[The specification which depend on the model]**

### CT-S281

When normal thermal paper mode is specified, the command is used, it becomes 2-color paper mode. It executes command <ESC @> or becomes effective until turning off power.

### CT-S280

- Depending on the setting of MSW4-7, function set by DC3 command is switched as per the table below.

n0	MSW4-7:DC3 command function	
	OFF=2 color printing	ON=Black/White reverse
0	2 color printing is invalid	B/W reverse printing is invalid.
1	2 color printing is valid.	B/W reverse printing is valid.

**[Default]** n=0

**[Sample Program]**

```
LPRINT CHR$(&H13); CHR$(1);
LPRINT "AAAAA"; CHR$(&HA);
LPRINT CHR$(&H13); CHR$(0);
LPRINT "AAAAA"; CHR$(&HA);
```

**[Print Results]**

A A A A A ← Red printing

A A A A A ← Black printing

\* When dedicated thermal paper (Black-based paper) is used.

# DC3 n (Valid in CBM1000-Compatible Mode)

Support model	CT-S280	CT-S300	CT-S2000	CT-S4000	BD2-2220	PMU series
	CT-S281	CT-S310	CT-S801/851	CT-S601/651	CT-P29x series	CT-S310 II

**[Function]** Specifies/cancels printing in red (black-based paper)

**[Code]** <13>H<n>

**[Range]** 0≤n≤255

**[Outline]** **[The specification which is common to the model]**

- Specifies or cancels printing in red.
- Red printing is valid on black-based thermal paper. Specifies or cancels printing in black on red-based thermal paper.
- "n" is valid only for the lowest bit (n0).
- Control by the lowest bit (n0) is shown as follows:

n0	Function	
	black-based paper	red-based paper
0	Specifying red printing.	Specifying black printing.
1	Canceling red printing.	Canceling black printing.

**[Caution]** **[The specification which is common to the model]**

- Valid when 2-color paper is specified by the GS ( E command.
- Valid only at the top of a line.
- This command must not be used for normal thermal paper.
- At the time of setting, conducting pulse amount is increased to change the coloring.
- In case of MSW3-7=OFF, this command is invalid.

**[Default]** n=0

**[Sample Program]**

```
LPRINT CHR$(&H13); CHR$(1);
LPRINT "AAAAA"; CHR$(&HA);
LPRINT CHR$(&H13); CHR$(0);
LPRINT "AAAAA"; CHR$(&HA);
```

**[Print Results]**

```

A A A A A ← Black printing
A A A A A ← Red printing
```

\* When dedicated thermal paper (Black-based paper) is used.



# GS ! n

Support model	CT-S280	CT-S300	CT-S2000	CT-S4000	BD2-2220	PMU series
	CT-S281	CT-S310	CT-S801/851	CT-S601/651	CT-P29x series	CT-S310 II

**[Function]** Specifying the character size

**[Code]** <1D>H<21>H<n>

**[Range]** 0≤n≤255  
Where: 1≤vertical magnification≤8, 1≤horizontal magnification≤8

**[Outline]** **[The specification which is common to the model]**  
• Specifies the character size (Vertical and horizontal magnification).

Bit	Function	Value	
		Hex. Number	Decimal Number
0	Vertical magnification specification	Refer to Table 2, "Vertical Magnification".	
1			
2			
3			
4	Horizontal magnification specification	Refer to Table 1, "Horizontal Magnification".	
5			
6			
7			

**Table 1 Horizontal Magnification**

Hex.	Decimal	Magnification
00H	0	1 × (Standard)
10H	16	2 × (Double width)
20H	32	3 ×
30H	48	4 ×
40H	64	5 ×
50H	80	6 ×
60H	96	7 ×
70H	112	8 ×

**Table 2 Vertical Magnification**

Hex.	Decimal	Magnification
00H	0	1 × (Standard)
01H	1	2 × (Double)
02H	2	3 ×
03H	3	4 ×
04H	4	5 ×
05H	5	6 ×
06H	6	7 ×
07H	7	8 ×

**[Caution]**

**[The specification which is common to the model]**

- This command is valid for all characters (alphanumeric, kana, and kanji) except for HRI characters.
- This command is ignored if either the vertical magnification or horizontal magnification is out of the defined range.
- In PAGE MODE, the vertical direction means the top-bottom direction of each character. The horizontal direction means the side-to-side direction of each character. If characters of different vertical magnification are contained in a line, the baseline of each character is lined up.
- Horizontal and vertical magnification can also be specified/canceled by ESC ! but the setting of command last processed is valid.
- In STANDARD MODE, the vertical direction is defined as the paper feed direction, and the horizontal direction is defined as the direction perpendicular to the paper feed.
- Setting memory SW 3-7 to ON allows the horizontal and vertical relations to be interchanged when 90°-right-turning of character is specified.

**[Default]**

n=0

**[See Also]**

[ESC!](#)

# GS B n

Support model	CT-S280	CT-S300	CT-S2000	CT-S4000	BD2-2220	PMU series
	CT-S281	CT-S310	CT-S801/851	CT-S601/651	CT-P29x series	CT-S310 II

**[Function]** Specifying/canceling the black/white inverted printing

**[Code]** <1D>H<42>H<n>

**[Range]** 0≤n≤255

- [Outline]** **[The specification which is common to the model]**
- This command specifies or cancels the black/white inverted printing.
  - "n" is valid only for the lowest bit (n0).
  - Control by the lowest bit (n0) is shown as follows:

n0	Function
0	The black/white inverted printing is canceled.
1	The black/white inverted printing is specified.

- [Caution]** **[The specification which is common to the model]**
- The black/white inversion works on internal and downloaded characters.
  - The black/white inversion works also on the right spacing of characters defined by ESC SP.
  - This command does not affect the bit image, downloaded bit image, bar code, HRI characters, or the skip area specified by HT, ESC \$, or ESC \.
  - This command does not affect the space between lines.
  - Black/white inversion specification takes precedence over underline specification. Underline printing specified is, therefore, nullified if black/white inversion is specified; the underline setting, however, remains unchanged.

**[Default]** n=0

# GS b n

Support model	CT-S280	CT-S300	CT-S2000	CT-S4000	BD2-2220	PMU series
	CT-S281	CT-S310	CT-S801/851	CT-S601/651	CT-P29x series	CT-S310 II

**[Function]** Specifying/canceling the smoothing

**[Code]** <1D>H<62>H<n>

**[Range]** 0≤n≤255

**[Outline]** **[The specification which is common to the model]**

- This command specifies or cancels the smoothing.
- "n" is valid only for the lowest bit (n0).
- Control by the lowest bit (n0) is shown as follows:

n0	Function
0	The smoothing is canceled.
1	The smoothing is specified.

**[Caution]** **[The specification which is common to the model]**

- Smoothing is effective to printer's internal characters, download characters, and non-standard characters.
- Smoothing is not effective to characters with either of their vertical or horizontal magnification is x1.

**[Default]** n=0

**[See Also]** [ESC!](#), [GS!](#)

## 2.2.4 Print Position Commands

# HT

Support model	CT-S280	CT-S300	CT-S2000	CT-S4000	BD2-2220	PMU series
	CT-S281	CT-S310	CT-S801/851	CT-S601/651	CT-P29x series	CT-S310 II

**[Function]** Horizontal tab

**[Code]** <09>H

**[Outline]** **[The specification which is common to the model]**

- Shifts the printing position to the next horizontal tab position.
- Ignored when the next horizontal tab position has not been set.

**[Caution]** **[The specification which is common to the model]**

- The horizontal tab position is set by ESC D.

**[Default]** At the selection of font A, tabs are set every 8 characters (at 9th, 17th, 25th, ...) with right space amount of a character set at 0 and horizontal enlargement rate of a character set at 1.

**[See Also]** [ESC D](#)

### [Sample Program]

```
LPRINT "012345678901234567890"; CHR$(&HA);
LPRINT CHR$(&H9);"AAA";
LPRINT CHR$(&H9);"BBB"; CHR$(&HA);
LPRINT CHR$(&H1B);"D";
LPRINT CHR$(3); CHR$(7); CHR$(14); CHR$(0);
LPRINT CHR$(&H9);"AAA";
LPRINT CHR$(&H9);"BBB";
LPRINT CHR$(&H9);"CCC"; CHR$(&HA);
```

### [Printing Result]

```
012345678901234567890
      AAA   BBB
      AAA  BBB   CCC
```

← Initially set horizontal tab

← When set to the 4th, 8th, and 15th columns

# ESC \$ n1 n2

Support model	CT-S280	CT-S300	CT-S2000	CT-S4000	BD2-2220	PMU series
	CT-S281	CT-S310	CT-S801/851	CT-S601/651	CT-P29x series	CT-S310 II

**[Function]** Specifying the absolute positions

**[Code]** <1B>H<24>H<n1><n2>

**[Range]**  $0 \leq n1 \leq 255$   
 $0 \leq n2 \leq 255$

**[Outline]** **[The specification which is common to the model]**

- The printing start position is specified by the absolute position from the left margin with the number of dots divided by 256 and quotient specified as "n2" and remainder as "n1". Therefore, the printing start position is designated as  $n1 + n2 \times 256 \times \text{basic calculation pitch}$  from the left margin.

**[Caution]** **[The specification which is common to the model]**

- The basic calculation pitch is set by GS P. After the line feed width is set, if the basic calculation by GS P leaves a fraction, the fraction is corrected with the minimum pitch of the mechanism, and the remainder is omitted.
- In STANDARD MODE, this command uses the horizontal (Paper feed direction) basic calculation pitch (x).
- In PAGE MODE, this command acts differently depending on the start point:
  - If the start point specified by ESC T is top right or bottom left, the command uses the vertical (Paper feed direction) basic calculation pitch (y).
  - If the start point specified by ESC T is top left or bottom right, the command uses the horizontal (Perpendicular to the paper feed direction) basic calculation pitch (x). Specification beyond the end of the line is ignored.

**[See Also]** [ESC \ GS P](#), [GS \ GS \\$](#)

**[Sample Program]**

```
LPRINT CHR$(&H1B);"$";
LPRINT CHR$(0); CHR$(0);"A";
LPRINT CHR$(&H1B);"$";
LPRINT CHR$(50); CHR$(0);"B";
LPRINT CHR$(&H1B);"$";
LPRINT CHR$(0); CHR$(1);"C"; CHR$(&HA);
LPRINT CHR$(&H1B);"$";
LPRINT CHR$(100); CHR$(0);"A";
LPRINT CHR$(&H1B);"";
LPRINT CHR$(&HC2); CHR$(&HFF);"B"; CHR$(&HA);
```

**[Print Results]**

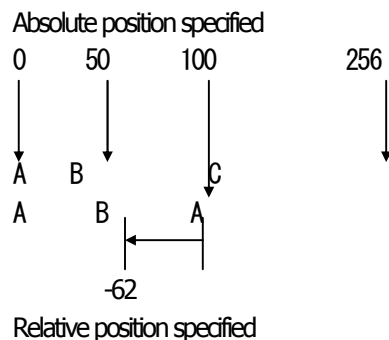

# ESC D [n] k NULL

support model	CT-S280	CT-S300	CT-S2000	CT-S4000	BD2-2220	PMU series
	CT-S281	CT-S310	CT-S801/851	CT-S601/651	CT-P29x series	CT-S310 II

**[Function]** Setting horizontal tab position

**[Code]** <1B>H<44>H [<n>] k<00>H

**[Range]** 1≤n≤255  
0≤k≤32

**[Outline]** **[The specification which is common to the model]**

- Specifying a horizontal tab position.
- "n" indicates the number of columns from the beginning to the horizontal tab position. Note, however, that "n = set position - 1". For example, to set the position at 9th column, n = 8 is to be specified.
- "k" denotes the number of horizontal tab positions you want to set.
- The tab position is set at a position where it is "character width×n" from the beginning of a line. The character width, at this time, includes the space on the right. In double width characters, it is made double the ordinary case.
- Tab positions that can be specified are maximum 32. Specifying tab positions exceeding this limit is ignored.
- <n> k, which denotes a setting position, is input in the increasing order and ends at 00H.
- ESC D <NULL> clears all the set tab positions. Following clearing, the horizontal tab command is ignored.

**[Caution]** **[The specification which is common to the model]**

- When the data, <n> k, is equal to or smaller than its preceding data, <n> k-1, it is assumed that tab setting is finished. If this is the case, the next data onward will be processed as normal data.
- When the data, <n> k, exceeds a 1-line print area, set the horizontal tab position, as "Set column position = Maximum print columns + 1".
- The horizontal tab position does not change even if the character width is altered after setting the horizontal tab position.

**[Default]** At the selection of font A, tabs are set every 8 characters (at 9th, 17th, 25th, ...) with right space amount of a character set at 0 and horizontal enlargement rate of a character set at 1.

**[See Also]** [HT](#)

**[Sample Program]**

[Refer to Sample Program and Print Results for HT.](#)

# ESC T n

support model	CT-S280	CT-S300	CT-S2000	CT-S4000	BD2-2220	PMU series
	CT-S281	CT-S310	CT-S801/851	CT-S601/651	CT-P29x series	CT-S310 II

**[Function]** Selecting the character printing direction in PAGE MODE

**[Code]** <1B>H<54>H<n>

**[Range]** 0≤n≤3, 48≤n≤51

**[Outline]** **[The specification which is common to the model]**

- Selects the direction and start point of character printing in PAGE MODE.

n	Printing Direction	Start Point
0, 48	Left to right	Top left ("A" in the figure)
1, 49	Bottom to top	Bottom left ("B" in the figure)
2, 50	Right to left	Bottom right ("C" in the figure)
3, 51	Top to bottom	Top right ("D" in the figure)

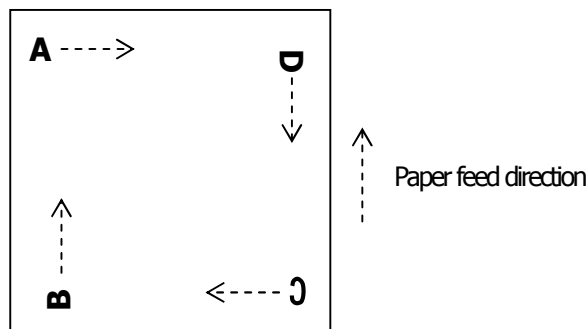

**[Caution]** **[The specification which is common to the model]**

- When STANDARD MODE is selected, this command only executes the internal flagging of the printer without affecting the printing in STANDARD MODE.
- The character mapping position will be the start point of the print area specified by ESC W.
- The basic calculation pitch (x or y) used by the following commands varies with the start point.
  - (1) If the start point is the top left or bottom right (The characters are mapped in the direction perpendicular to the paper feed),
    - Commands using x: ESC SP, ESC S, ESC \
    - Commands using y: ESC 3, ESC J, GS \$, GS \
  - (2) If the start point is the top right or bottom left (The characters are mapped in the paper feed direction),
    - Commands using x: ESC 3, ESC J, GS \$, GS \
    - Commands using y: ESC SP, ESC S, ESC \

**[Default]** n=0

**[See Also]** [Appendix 5.1 "Explanation on PAGE MODE"](#)  
[ESC \\$](#), [ESCL](#), [ESC W](#), [ESC \](#), [GS \\$](#), [GS P](#), [GS \](#)



# ESC W xL xH yL yH dxL dxH dyL dyH

support model	CT-S280	CT-S300	CT-S2000	CT-S4000	BD2-2220	PMU series
	CT-S281	CT-S310	CT-S801/851	CT-S601/651	CT-P29x series	CT-S310 II

**[Function]** Defining the print area in PAGE MODE

**[Code]** <1B>H<57>H<xL><xH><yL><yH><dxL><dxH><dyL><dyH>

**[Range]**  $0 \leq xL, xH, yL, yH, dxL, dxH, dyL, dyH \leq 255$   
except for  $dxL=dxH=0$  or  $dyL=dyH=0$

**[Outline]** **[The specification which is common to the model]**

- Defines the location and size of the print area.
- Horizontal start point =  $[(xL+xH \times 256) \times \text{basic calculation pitch}]$  inches
- Vertical start point =  $[(yL+yH \times 256) \times \text{basic calculation pitch}]$  inches
- Horizontal length =  $[(dxL+dxH \times 256) \times \text{basic calculation pitch}]$  inches
- Vertical length =  $[(dyL+dyH \times 256) \times \text{basic calculation pitch}]$  inches

**[Caution]** **[The specification which is common to the model]**

- When STANDARD MODE is selected, this command only executes the internal flagging of the printer without affecting the printing in STANDARD MODE.
- If the horizontal start point or vertical start point is out of the printable area, this command is canceled and the next data is handled as normal data.
- If the horizontal length or vertical length is 0, this command is canceled and the next data is handled as normal data.
- The character mapping position will be the start point specified by ESC T in the print area.
- If the "horizontal start point + horizontal length" is greater than the horizontal printable area, the "horizontal printable area – horizontal start point" is taken as the horizontal length.
- If the "vertical start point + vertical length" is greater than the vertical printable area, the "vertical printable area – vertical start point" is taken as the vertical length.
- The basic calculation pitch is defined by GS P. Once defined, the print area is not changed if the basic calculation pitch is changed by GS P.
- Fractions resulting from calculations are corrected with the minimum pitch of the mechanism, and the remainder is omitted.
- The horizontal start point and horizontal length are calculated with the basic calculation pitch (x). The vertical start point and vertical length are calculated with the basic calculation pitch (y).
- The figure below illustrates the print area, where X = horizontal start point, Y = vertical start point, Dx = horizontal length, and Dy = vertical length.

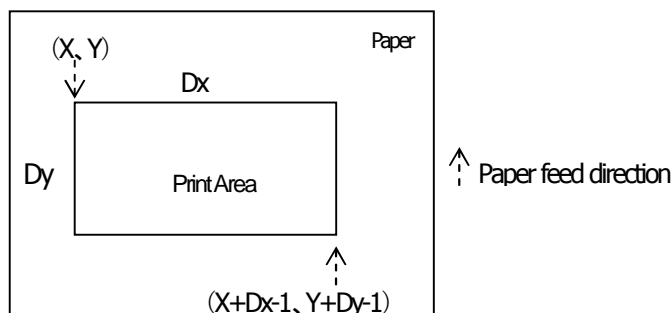

- The printable area is approximately 117 mm (938/203 inches) vertically, and horizontal area depends on the model. (Refer to the below Table)

**[Default]**

xL=xH=yL=yH=0

dyL=126, dyH=6

dxL,dxH depends on paper width. (Refer to the below Table)

paper width	print width/(dot)	dxL	dxH	support model
112mm	104mm/(832)	96	3	CT-S4000
112mm	90mm/(720)	208	2	CT-S4000
83mm	82.5mm/(660)	148	2	CT-S4000
83mm	80mm/(640)	128	2	CT-S2000/CT-S801/CT-S851/CT-S601/CT-S651
80mm	72mm/(576)	64	2	CT-S300/CT-S310/CT-S2000/CT-S4000/CT-S801/CT-S851 CT-S601/CT-S651/BD2-2220/ PMU series/CT-P293/CT-S310II
80mm	68.25mm(546)	34	2	CT-S801/CT-S851/CT-S601/CT-S651/CT-S310II
80mm	64mm/(512)	0	2	CT-S300/CT-S310/CT-S2000/CT-S4000/CT-S801/CT-S851 CT-S601/CT-S651/CT-S310II
60mm	54.5mm/(436)	180	1	CT-S2000/CT-S801/CT-S851/CT-S601/CT-S651
58mm	54mm/(432)	176	1	CT-S2000/CT-S4000/CT-S801/CT-S851/CT-S601/CT-S651 BD2-2220/PMU2XXX/PMU2XXXII
58mm	52.5mm/(420)	156	1	CT-S2000/CT-S801/CT-S851/CT-S601/CT-S651/CT-S310II
58mm	51mm/(408)	152	1	CT-P291
58mm	48.75mm(390)	134	1	CT-S801/CT-S851/CT-S601/CT-S651/CT-S310II
58mm	48mm/(384)	128	1	CT-S280/CT-S281/CT-S300/CT-S310/CT-S2000 CT-S801/CT-S851/CT-S601/CT-S651/CT-P291/293/CT-S310II
58mm	45mm/(360)	104	1	CT-S300/CT-S310/CT-S2000/CT-S4000/CT-S801/CT-S851 CT-S601/CT-S651/CT-S310II

**[See Also]**

[Appendix 5.1 "Explanation on PAGE MODE"](#)

[CAN](#), [ESCL](#), [ESC T](#), [GS P](#)

# ESC \ nL nH

support model	CT-S280	CT-S300	CT-S2000	CT-S4000	BD2-2220	PMU series
	CT-S281	CT-S310	CT-S801/851	CT-S601/651	CT-P29x series	CT-S310 II

**[Function]** Specifying the relative position

**[Code]** <1B>H<5C>H<nL><nH>

**[Range]**  $0 \leq nL \leq 255$   
 $0 \leq nH \leq 255$

**[Outline]** **[The specification which is common to the model]**

- This command specifies the next print start position in a relative position with respect to the current position.
- The next print start position will be at a point of  $[(nL+nH \times 256) \times \text{basic calculation pitch}]$  inches away from the current position.

**[Caution]** **[The specification which is common to the model]**

- Specification of a position outside the print area is ignored.
- If a new position is specified to the right of the current position in the direction of printing, it should be specified as positive (+). If it is to the left, it should be as negative (-).
- A negative value is the complement of 65536. For example, to move the position by N pitches to the left, specify it as:  $nL + nH \times 256 = 65536 - N$
- Fractions resulting from calculation are corrected with the minimum pitch of the mechanism, and the remainder is omitted.
- In STANDARD MODE, this command uses the horizontal basic calculation pitch (x).
- In PAGE MODE, this command acts differently depending on the start point:
  - (1) If the start point specified by ESC T is top left or bottom right, the command specifies the relative position in the direction perpendicular to the paper feed (The character's side-to-side direction), using the horizontal basic calculation pitch (x).
  - (2) If the start point is top right or bottom left, the command specifies the relative position in the paper feed direction (The character's side-to-side direction), using the vertical basic calculation pitch (y).

**[See Also]** [ESC \\$](#), [GS P](#)

**[Sample Program]**  
[Refer to Sample Program and Print Results for ESC \\$.](#)

# ESC a n

support model	CT-S280	CT-S300	CT-S2000	CT-S4000	BD2-2220	PMU series
	CT-S281	CT-S310	CT-S801/851	CT-S601/651	CT-P29x series	CT-S310 II

**[Function]** Aligning the characters

**[Code]** <1B>H<61>H<n>

**[Range]** 0≤n≤2, 48≤n≤50

**[Outline]** **[The specification which is common to the model]**

- All the printed data within one line are aligned in the specified position.
- Depending on the value "n", positional alignment is carried out as shown in the table below:

n	Position
0, 48	Left end alignment
1, 49	Centering
2, 50	Right end alignment

**[Caution]** **[The specification which is common to the model]**

- This command is valid only when it is inputted at the beginning of a line.
- This command does not affect the PAGE MODE.
- Executes justification in the print area being set.

**[Default]** n=0

**[Sample Program]**

```
LPRINT CHR$(&H1B);"a"; CHR$(0);
LPRINT "AAAAA"; CHR$(&HA);
LPRINT CHR$(&H1B);"a"; CHR$(1);
LPRINT "AAAAA"; CHR$(&HA);
LPRINT CHR$(&H1B);"a"; CHR$(2);
LPRINT "AAAAA"; CHR$(&HA);
```

**[Print Results]**



# GS \$ nL nH

support model	CT-S280	CT-S300	CT-S2000	CT-S4000	BD2-2220	PMU series
	CT-S281	CT-S310	CT-S801/851	CT-S601/651	CT-P29x series	CT-S310 II

- [Function]** Specifying the absolute position of character vertical direction in PAGE MODE
- [Code]** <1D>H<24>H<nL><nH>
- [Range]** 0≤nL≤255, 0≤nH≤255
- [Outline]** **[The specification which is common to the model]**
- Specifies the vertical position of character at the start point of data development in PAGE MODE using absolute position based on the start position.
  - The position of vertical direction of character at the start position of next data development is the position [(nL+nH×256)×basic calculation pitch] from the start position.
- [Caution]** **[The specification which is common to the model]**
- This command is ignored except at PAGE MODE selection.
  - Absolute position setting exceeding the specified print area is ignored.
  - Position in horizontal direction of character at the start position of data development is not shifted.
  - Start point used as the reference is set by ESC T.
  - The following operation occurs at the start point of ESC T.
    - (1) When start point is set at "upper left" or "lower right", the absolute position of paper feed direction (vertical direction of character) is set. In this case, basic calculation pitch (y) of vertical direction is used.
    - (2) When start point is set at "upper right" or "lower left", the absolute position of vertical direction of paper feed (vertical direction of character) is set. In this case, basic calculation pitch (x) of horizontal direction is used.
  - Basic calculation pitch is set by GS P.
  - When fractional number is caused by the calculation, it is corrected by the minimum pitch of mechanism and the rest is discarded.
- [See Also]** [ESC \\$](#), [ESC T](#), [ESC W](#), [ESC \](#), [GS P](#), [GS \](#)

# GS L nL nH

support model	CT-S280	CT-S300	CT-S2000	CT-S4000	BD2-2220	PMU series
	CT-S281	CT-S310	CT-S801/851	CT-S601/651	CT-P29x series	CT-S310 II

**[Function]** Setting the left margin

**[Code]** <1D>H<4C>H<nL><nH>

**[Range]**  $0 \leq nL \leq 255, 0 \leq nH \leq 255$

**[Outline]** **[The specification which is common to the model]**

- This command sets the left margin specified by nL and nH.
- The value of the left margin is  $[(nL+nH \times 256) \times \text{basic calculation pitch}]$  inches.

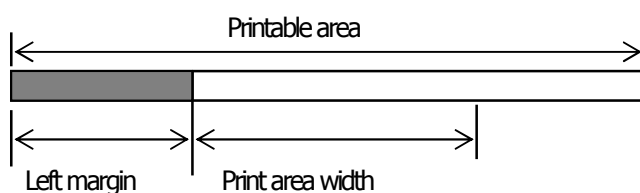

**[Caution]** **[The specification which is common to the model]**

- This command only works when it is entered at the beginning of a line.
- When PAGE MODE is selected, this command only executes the internal flagging of the printer.
- The setting of this command does not affect PAGE MODE.
- The maximum settable left margin is equal to the horizontal printable area. A setting greater than this maximum is trimmed to the maximum.
- The basic calculation pitch is defined by GS P. Once defined, the left margin is not changed if the basic calculation pitch is changed by GS P.
- The left margin is calculated with the horizontal basic calculation pitch (x) set by GS P. A fraction resulting from the calculation is corrected with the minimum pitch of the mechanism, and the remainder is omitted.
- When you progress the first character in start of the line, if the print area specified is not wide enough to accommodate the wide of one character(\*Right space is contained.),only the line for that character data is handled as follows:
  - (1) The print area is extended toward the right to be equivalent to one character of the current font, but not wider than the printable area.
  - (2) If an area for one character cannot be provided as a result of step (1), the print area is extended toward the left. (So, the left margin is decreased.)
- When mapping non-character data (bit image, downloaded bit image, or bar code), if the print area specified is narrower than 9-bits, only the line for that data is handled as follows:
  - (1) The print area is extended toward the left (so, the left margin is decreased) until it is 9-dot wide, but not wider than the printable area.

**[Default]** nL=0, nH=0

**[See Also]** [GSP](#), [GSW](#)

# GS W nL nH

Support model	CT-S280	CT-S300	CT-S2000	CT-S4000	BD2-2220	PMU series
	CT-S281	CT-S310	CT-S801/851	CT-S601/651	CT-P29x series	CT-S310 II

**[Function]** Setting the print area width

**[Code]** <1D>H<57>H<nL><nH>

**[Range]**  $0 \leq nL \leq 255$   
 $0 \leq nH \leq 255$

- [Outline]** **[The specification which is common to the model]**
- Sets the print area width specified by nL and nH.
  - The print area width will be  $[(nL+nH \times 256) \times \text{basic calculation pitch}]$  inches.

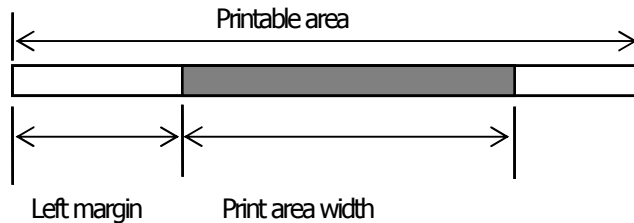

- [Caution]** **[The specification which is common to the model]**
- This command only works when it is entered at the beginning of a line.
  - When PAGE MODE is selected, this command only executes the internal flagging of the printer.
  - The setting of this command does not affect PAGE MODE.
  - If the value entered with this command exceeds the printable area for one line, the entire area except the left margin is set as the print area width.
  - The basic calculation pitches are defined by GS P. Once defined, the print area width is not changed if the basic calculation pitch is changed by GS P.
  - The print area width is calculated with the horizontal basic calculation pitch (x) defined by GS P. A fraction resulting from the calculation is corrected with the minimum pitch of the mechanism, and the remainder is omitted.
  - If the first character to be mapped at the beginning of a line has a width (including the right spacing) greater than the print area width, only that line is handled as follows:

(1) The print area is extended toward the right to accommodate the first character, but not wider than the printable area.

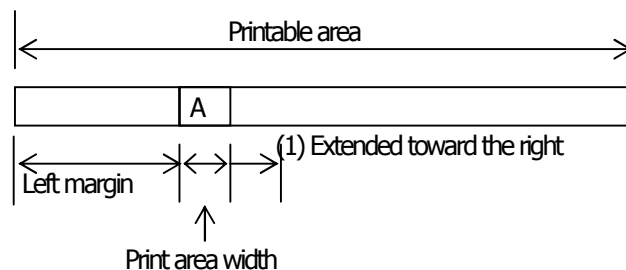

- (2) If a sufficient area cannot be provided as a result of step (1), the print area is extended toward the left (so, the left margin is decreased).

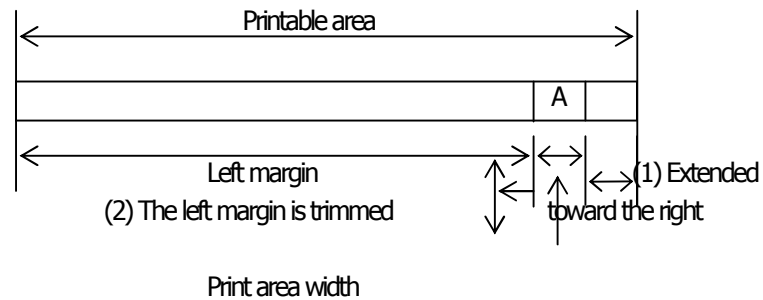

- (3) If a sufficient area cannot be provided as a result of step (2), the right spacing is trimmed.

- When mapping a bit image (or downloaded bit image), if the print area is narrower than the minimum width of the bit image (two dots for single density, or one dot for double density), only the line for that image is handled as follows:

- (1) The print area is extended toward the left (so, the left margin is decreased) until it is equal to the minimum width of the image, but not wider than the printable area.

**[Default]**

paper width	print width/(dot)	nL	nH	support model
112mm	104mm/(832)	96	3	CT-S4000
112mm	90mm/(720)	208	2	CT-S4000
83mm	82.5/(660)	148	2	CT-S4000
83mm	80mm/(640)	128	2	CT-S2000/CT-S801/CT-S851/CT-S601/CT-S651
80mm	72mm/(576)	64	2	CT-S300/CT-S310/CT-S2000/CT-S4000/CT-S801/CT-S851 CT-S601/CT-S651/BD2-2220/PMU series/CT-P293/CT-S310II
80mm	68.25mm(546)	34	2	CT-S801/CT-S851/CT-S601/CT-S651/CT-S310II
80mm	64mm(512)	0	2	CT-S300/CT-S310/CT-S2000/CT-S4000 CT-S801/CT-S851/CT-S601/CT-S651/CT-S310II
60mm	54.5mm/(436)	180	1	CT-S2000/CT-S801/CT-S851/CT-S601/CT-S651
58mm	54mm/(432)	176	1	CT-S2000/CT-S4000/CT-S801/CT-S851/CT-S601/CT-S651 BD2-2220/PMU2XXX/PMU2XXXII
58mm	52.5mm/(420)	156	1	CT-S2000/CT-S801/CT-S851/CT-S601/CT-S651/CT-S310II
58mm	51mm(408)	152	1	CT-P291
58mm	48.75mm(390)	134	1	CT-S801/CT-S851/CT-S601/CT-S651/CT-S310II
58mm	48mm/(384)	128	1	CT-S280/CT-S281/CT-S300/CT-S310/CT-S2000 CT-S801/CT-S851/CT-S601/CT-S651/CT-P291/293 CT-S310II
58mm	45mm/(360)	104	1	CT-S300/CT-S310/CT-S2000/ CT-S4000/CT-S801/CT-S601/CT-S310II

**[See Also]** [GSL](#), [GSP](#)



# GS \ nL nH

Support model	CT-S280	CT-S300	CT-S2000	CT-S4000	BD2-2220	PMU series
	CT-S281	CT-S310	CT-S801/851	CT-S601/651	CT-P29x series	CT-S310 II

- [Function]** Specifying the relative vertical position of a character in PAGE MODE
- [Code]** <1D>H<5C>H<nL><nH>
- [Range]**  $0 \leq nL \leq 255, 0 \leq nH \leq 255$
- [Outline]** **[The specification which is common to the model]**
- This command is used in PAGE MODE to specify the vertical position of a character in the data mapping start position, in a relative position with respect to the current position.
  - The next data mapping start position will be at a point  $[(nL+nH \times 256) \times \text{basic calculation pitch}]$  inches away from the current position.
- [Caution]** **[The specification which is common to the model]**
- This command is ignored when PAGE MODE is not selected.
  - If a new position is specified for a character located beneath the current position, it should be specified as positive (+). If it is above the current position, it should be negative (-).
  - A negative value is the complement of 65536. For example, to move the position by N pitches up, specify it as:  
 $nL + nH \times 256 = 65536 - N$
  - The specification of a relative position outside the specified print area is ignored.
  - Depending on the start point specified by ESC T, this command acts as follows:
    - (1) If the start point is the top left or bottom right, the command specifies the relative position in the paper feed direction (the character's top-bottom direction) using the vertical basic calculation pitch (y).
    - (2) If the start point is the top right or bottom left, the command specifies the relative position in the direction perpendicular to the paper feed (the character's top-bottom direction) using the horizontal basic calculation pitch (x).
  - The basic calculation pitch is set by GS P.
  - Fractions resulting from calculations are corrected with the minimum pitch of the mechanism, and the remainder is omitted.

## 2.2.5 Line Feed Span Commands

# ESC 2

Support model	CT-S280	CT-S300	CT-S2000	CT-S4000	BD2-2220	PMU series
	CT-S281	CT-S310	CT-S801/851	CT-S601/651	CT-P29x series	CT-S310 II

**[Function]** Specifying 1/6-inch line feed rate

**[Code]** <1B>H<32>H

**[Outline]** **[The specification which depend on the model]**  
CT-S280/CT-S281/CT-S300/CT-S310/BD2-2220/PMU series  
CT-P29x series

The line feed rate per line is specified by 1/6 inch.

CT-S2000/CT-S4000/CT-S801/CT-S851/CT-S601/CT-S651/CT-S301II

The line feed rate per line is specified by MSW5-2 setting.

**[Caution]** **[The specification which is common to the model]**  
• Line feed rate can be specified respectively for both STANDARD MODE and PAGE MODE.

**[Default]** **[The specification which depend on the model]**  
CT-S280/CT-S281/CT-S300/CT-S310/BD2-2220/PMU series  
CT-P29x series

Approx. 4.23mm (1/360 inches)

CT-S2000/CT-S4000/CT-S801/CT-S851/CT-S601/CT-S651/CT-S301II

(1) MSW 5-2 OFF:

Approx. 4.23mm

(2) MSW 5-2 ON:

Approx. 3.75 mm

# ESC 3 n

Support model	CT-S280	CT-S300	CT-S2000	CT-S4000	BD2-2220	PMU series
	CT-S281	CT-S310	CT-S801/851	CT-S601/651	CT-P29x series	CT-S310 II

**[Function]** Setting line feed rate of minimum pitch

**[Code]** <1B>H<33>H<n>

**[Range]**  $0 \leq n \leq 255$

**[Outline]** **[The specification which is common to the model]**  
Sets the line feed width per line to [n×basic calculation pitch] inches.

**[Caution]** **[The specification which is common to the model]**

- The line feed width can be set separately for the STANDARD and PAGE MODES.
- The basic calculation pitch is set by GS P. Once defined, the line feed width is not changed if the basic calculation pitch is changed by GS P.
- Fractions resulting from calculation are corrected with the minimum pitch of the mechanism, and the remainder is omitted.
- In STANDARD MODE, this command uses the vertical (paper feed direction) basic calculation pitch (y).
- In PAGE MODE, this command acts differently depending on the start point:
  - (1) If the start point specified by ESC T is top left or bottom right, the command uses the vertical (paper feed direction) basic calculation pitch (y).
  - (2) If the start point specified by ESC T is top right or bottom left, the command uses the horizontal (perpendicular to the paper feed direction) basic calculation pitch (x).
- The maximum settable line feed width is 1016 mm (40 inches). A setting greater than this maximum is trimmed to the maximum.

**[Default]** **[The specification which depend on the model]**  
**CT-S280/CT-S281/CT-S300/CT-S310/BD2-2220/PMU series**  
**CT-P29x series**

Approx. 4.23mm

**CT-S2000/CT-S4000/CT-S801/CT-S851/CT-S601/CT-S651**

(1) MSW 5-2 OFF:

Approx. 4.23mm

(2) MSW 5-2 ON:

Approx. 3.75 mm

**[See Also]** [ESC2](#), [GSP](#)

## 2.2.6 Bit Image Commands

# ESC \* m n1 n2 [d] k

Support model	CT-S280	CT-S300	CT-S2000	CT-S4000	BD2-2220	PMU series
	CT-S281	CT-S310	CT-S801/851	CT-S601/651	CT-P29x series	CT-S310 II

**[Function]** Specifying the bit image mode

**[Code]** <1B>H<2A>H<m>H<n1><n2> [<d>]k

**[Range]** m=0, 1, 32, 33  
 0≤n1≤255, 0≤n2≤2  
 0≤d≤255  
 k=n1+256×n2 (m=0, 1), k=(n1+256×n2)×3 (m=32, 33)

**[Outline]** **[The specification which is common to the model]**

- According to the number of dots specified in "n1", "n2", specify the bit image of mode "m".
- The number of dots printed is divided by 256, whose quotient is taken as n2 and residual as "n1". The total number of dots printed in the horizontal direction is equal to n1+(256×n2).
- When bit image data have been input in excess of dot positions that can be printed on one line, the excess data are discarded.
- "d" is bit image data. Bits to be printed are specified as "1" and those not as "0".
- The bit image modes specified by "m" are shown as follows:

m	Mode	Vertical Direction		Horizontal Direction	
		Dot Count	Dot Density	Dot Density	Maximum Dot Count
0	8 dot single density	8	67dpi	101dpi	(1)
1	8 dot double density	8	67dpi	203dpi	(2)
32	24 dot single density	24	203dpi	101dpi	(3)
33	24 dot double density	24	203dpi	203dpi	(4)

**[The specification which depend on the model]**

(1) - (4) unit: dpi

support model	paper width	print width	(1)	(2)	(3)	(4)
CT-S4000	112mm	104mm	416	832	416	832
CT-S4000	112mm	90mm	360	720	360	720
CT-S4000	83mm	82.5mm	330	660	330	660
CT-S2000/CT-S801/CT-S851/CT-S601/CT-S651	83mm	80mm	320	640	320	640
CT-S300/CT-S310/CT-S2000/CT-S4000/CT-S801/CT-S851/CT-S601/CT-S651/BD2-2220/PMU series/CT-P293/CT-S310II	80mm	72mm	286	576	286	576
CT-S801/CT-S601/CT-S310II	80mm	68.25mm	273	546	273	546
CT-S300/CT-S310/CT-S2000/CT-S4000/CT-S801/CT-S851/CT-S601/CT-S651/CT-S310II	80mm	64mm	256	512	256	512
CT-S2000/CT-S801/CT-S601	60mm	54.5mm	218	436	218	436
CT-S2000/CT-S4000/CT-S801/CT-S851/CT-S601/CT-S651/BD2-2220/PMU2XXX/PMU2XXXII	58mm	54mm	216	432	216	432
CT-S2000/CT-S801/CT-S851/CT-S601/CT-S651/CT-S310II	58mm	52.5mm	210	420	210	420
CT-P291	58mm	51mm	204	408	204	408
CT-S801/CT-S851/CT-S601/CT-S651/CT-S310II	58mm	48.75mm	195	390	195	390
CT-S280/CT-S281/CT-S300/CT-S310/CT-S2000/CT-S801/CT-S851/CT-S601/CT-S651/CT-P291/293/CT-S310II	58mm	48mm	192	384	192	384
CT-S300/CT-S310/CT-S2000/CT-S4000/CT-S801/CT-S851/CT-S601/CT-S651/CT-S310II	58mm	45mm	180	360	180	360

- [Caution]**
- When the value of "m" is out of the above range, the data following after "n1" is processed as normal printing data.
  - After completion of bit image printing, the printer returns to normal data processing mode.

# GS \* n1 n2 [d] n1xn2x8

Support model	CT-S280	CT-S300	CT-S2000	CT-S4000	BD2-2220	PMU series
	CT-S281	CT-S310	CT-S801/851	CT-S601/651	CT-P29x series	CT-S310 II

**[Function]** Defining the download bit image

**[Code]** <1D>H<2A>H<n1><n2> [<d>] n1xn2x8

**[Range]**  
 $1 \leq n1 \leq 255$   
 $1 \leq n2 \leq 48$   
 $n1 \times n2 \leq 1536$

**[Outline]** **[The specification which is common to the model]**

- Defines download bit images of the number of dots specified by "n1" and "n2".
- The numbers of dots are n1x8 in horizontal direction and n2x8 in vertical direction.
- "d" indicates bit image data.
- Once defined, the download bit image remains effective until it is redefined, ESC @, ESC &, GS (A, or FS q, is executed, or power is turned OFF.

**[Caution]** **[The specification which is common to the model]**

- Relations between the bit image data and the dots defined are shown below.

**[The specification which depend on the model]**

**CT-S280/CT-S281/CT-S300/CT-S310/BD2-2220/PMU series**  
**CT-P29x series**

- With this command executed, the defined content of a downloaded character is cleared.

**CT-S2000/CT-S4000/CT-S801/CT-S851/CT-S601/CT-S651**

- With this command executed, the defined content of a downloaded character is not cleared.

**[See Also]** [GS/](#)

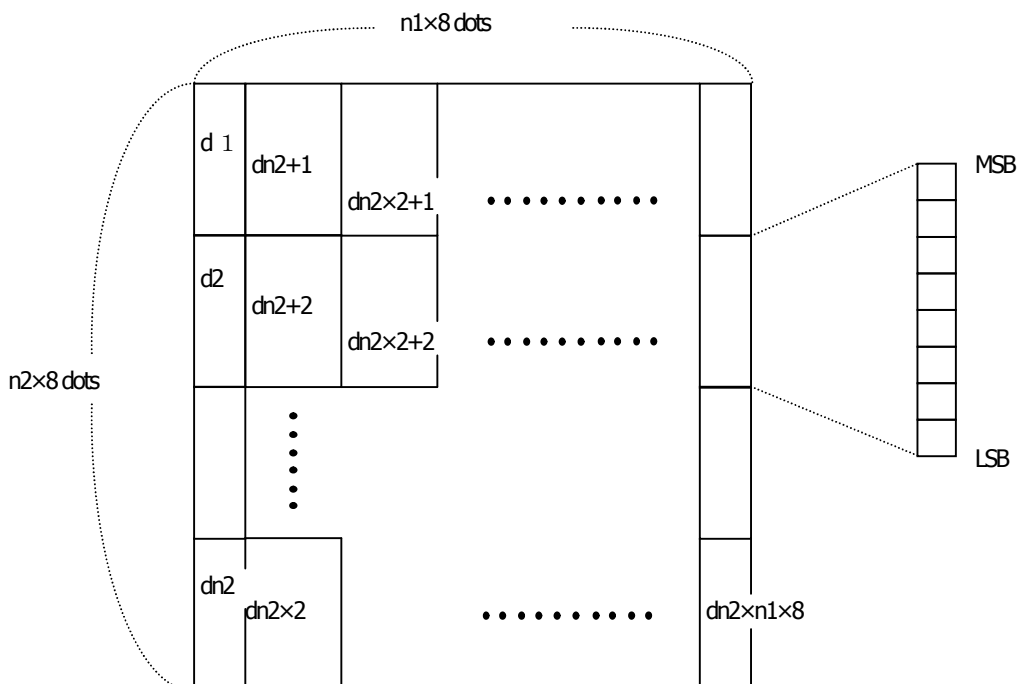

# GS / m

Support model	CT-S280	CT-S300	CT-S2000	CT-S4000	BD2-2220	PMU series
	CT-S281	CT-S310	CT-S801/851	CT-S601/651	CT-P29x series	CT-S310 II

**[Function]** Printing the downloaded bit image

**[Code]** <1D>H<2F>H<m>

**[Range]** 0≤m≤3, 48≤m≤51

**[Caution]** **[The specification which is common to the model]**

- Prints downloaded bit image in a mode specified by "m".
- Modes that can be selected by "m" are shown below.

m	Mode Name	Dot Density in Vertical Direction	Dot Density in Horizontal Direction
0, 48	NORMAL MODE	203DPI	203DPI
1, 49	DOUBLE WIDTH MODE	203DPI	101DPI
2, 50	DOUBLE HEIGHT MODE	101DPI	203DPI
3, 51	QUADRUPLE SIZE MODE	101DPI	101DPI

**[Caution]** **[The specification which is common to the model]**

- When a downloaded bit image has not been defined, this command is ignored.
- When data exist in the print buffer, this command is ignored.
- A portion of a downloaded bit image exceeding one line length is not printed.

**[See Also]** [ESC & GS\\*](#)

# GS v 0 m xL xH yL yH d1 ... dk

Support model	CT-S280	CT-S300	CT-S2000	CT-S4000	BD2-2220	PMU series
	CT-S281	CT-S310	CT-S801/851	CT-S601/651	CT-P29x series	CT-S310 II

**[Function]** Printing of raster bit image

**[Code]** <1D>H<76>H<30>H<m><xL><xH><yL><yH> [<d>] k

**[Range]**  $0 \leq m \leq 3$ ,  $48 \leq m \leq 51$ ,  $0 \leq xL \leq 255$ ,  $0 \leq xH \leq 255$ ,  
 $0 \leq yL \leq 255$ ,  $0 \leq yH \leq 8$ ,  $0 \leq d \leq 255$ ,  
 $k = (xL + xH \times 256) \times (yL + yH \times 256)$ , however,  $k \neq 0$

**[Outline]** **[The specification which is common to the model]**

- Prints raster bit images in mode "m".

m	Mode Name	Dot Density in Vertical Direction	Dot Density in Horizontal Direction
0, 48	NORMAL MODE	203dpi	203dpi
1, 49	DOUBLE WIDTH MODE	203dpi	101dpi
2, 50	DOUBLE HEIGHT MODE	101dpi	203dpi
3, 51	QUADRUPLE SIZE MODE	101dpi	101dpi

- xL, xH specify the number of data in horizontal direction of the bit image to  $(xL + xH \times 256)$  bytes.
- yL, yH specify the number of data in vertical direction of the bit image to  $(yL + yH \times 256)$  bytes.

**[Caution]** **[The specification which is common to the model]**

- Any of the print modes (character size, emphasis, double strike, inverting, underlining, back-to-white reversing, etc.) does not affect the raster bit image.
- If the print area specified by GS L and GS W is narrower than a minimum width, the print area for that line only is extended to the minimum width. The minimum width is one dot in NORMAL MODE (m=0, 48) and DOUBLE HEIGHT MODE (m=2, 50), and 2 dots in DOUBLE WIDTH MODE (m=1, 49) and QUADRUPLE SIZE MODE (m=3, 51).
- Any part of data that is out of the print area is only read and discarded in units of dot.
- The print start position can arbitrarily be specified with HT (horizontal tab), ESC \$ (specifying absolute position), ESC \ (specifying relative positions), and GS L (setting left margins). Note that if the print start position is not a multiple of 8, the printing speed may decrease.
- The setting of ESC a (aligning characters) are also valid for the raster bit image.
- If this command is executed during macro definition, the macro definition is suspended, and the processing of the command starts. The macro is left undefined.
- "d" denotes defined data. Dots to be printed are specified as "1", and those not to be printed as "0".
- Valid only when no print data is present in the print buffer at the selection of STANDARD MODE.

**[Example]** When  $x_L + x_H \times 256 = 64$

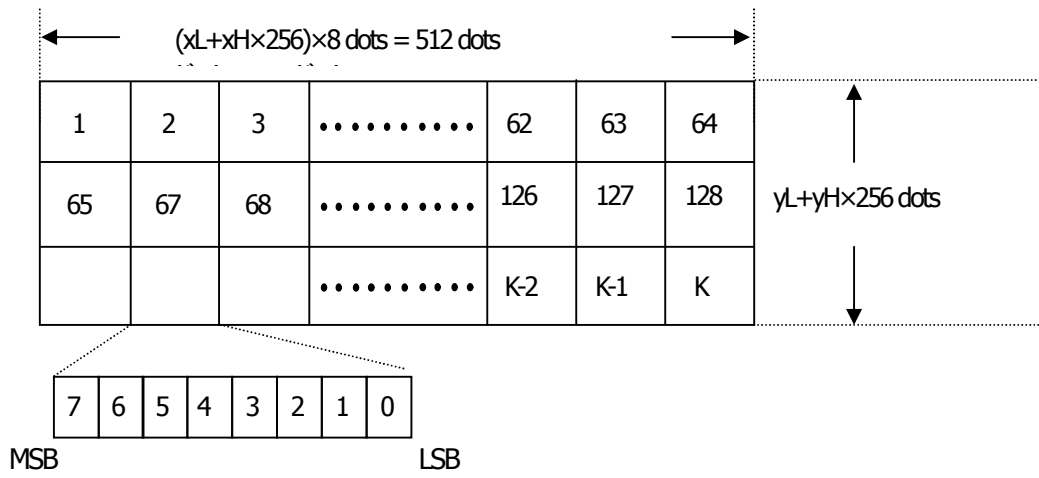



## 2.2.7 Status Commands

# DLE EOT n

Support model	CT-S280	CT-S300	CT-S2000	CT-S4000	BD2-2220	PMU series
	CT-S281	CT-S310	CT-S801/851	CT-S601/651	CT-P29x series	CT-S310 II

**[Function]** Sending status in real-time

**[Code]** <10>H<04>H<n>

**[Range]** 1≤n≤4

**[Outline]** **[The specification which is common to the model]**

- Sends in real-time the status specified by "n".

n	Status
1	Printer status
2	Status caused by an offline condition
3	Status caused by an error
4	Continuous paper detector status

**[Caution]**

- Each status represents the current status. It is 1 byte data.
- The status is transferred without checking whether the host is ready to receive or busy.
- This command is executed even if the printer is in offline state, receive-buffer full state, or error state.
- This command is dealt with when it is received.
- With serial interface specifications, this command is executed in offline state, receiving buffer full state, and error state.
- With parallel interface specifications, this command cannot be executed while the printer is in Busy state. When memory SW1-3 is ON, the printer does not enter Busy state in the offline state and error state.
- If ASB (Automatic Status Back) is enabled by GS a, it is necessary to discriminate between the status due to ASB and the status due to this command
- This command can be executed even if printer setting by ESC = is invalid.
- If another data string of 10H 04H n (1 n 4) is received, the printer acts the same way as with this command. Therefore, the user should be reminded of this fact.

[Example 1]

Suppose a command "ESC \* m nL nH [d1 ... dk] ", where d1 = 10H, d2 = 04H, d3 = 01H.

- The DLE EOT n command cannot be interleaved into the code string of another command consisting of 2 bytes or more.

[Example 2]

If the printer sends DLE EOT 3 after the host has sent up to ESC 3 in its attempt to send ESC 3 n, the printer handles the ESC 3 as ESC 3 10H. Thus, the user should be cautious.

**[See Also]**

[Appendix 5.3 "Identification of Send Status"](#)  
[DLE ENQ](#), [ESC c 4](#), [GS a](#), [GS r](#)

**CT-S280**

(1) Printer status (When n = 1 is specified)

Bit	Status	Hex.	Decimal
0	Fixed	00H	0
1	Fixed	02H	2
2	Fixed	00H	0
3	Online status	00H	0
	Offline status	08H	8
4	Fixed	10H	16
5	Not waiting online recovery	00H	0
	Waiting online recovery	20H	32
6	FEED switch is not pressed	00H	0
	FEED switch is pressed	40H	64
7	Fixed	00H	0

(2) Status caused by an offline condition (When n = 2 is specified)

Bit	Status	Hex.	Decimal
0	Fixed	00H	0
1	Fixed	02H	2
2	Cover closed	00H	0
	Cover open	04H	4
3	Not in paper feed state triggered by FEED switch	00H	0
	In paper feed state triggered by FEED switch	08H	8
4	Fixed	10H	16
5	Printing is not stopped because of "paper out" state	00H	0
	Printing is stopped because of "paper out" state	20H	32
6	Error not occurred	00H	0
	Error occurred	40H	64
7	Fixed	00H	0

Bit 5: Printing is stopped if the Paper-end detector detects a "paper out" state, or if the printer is out of paper when the Paper Near-end Sensor is enabled by ESC c 4. At this time, bit 5= 1.

(3) Status caused by an error (when n = 3 is specified)

Bit	Status	Hex.	Decimal
0	Fixed	00H	0
1	Fixed	02H	2
2	Fixed	00H	0
3	Fixed	00H	0
4	Fixed	10H	16
5	Unrecoverable error not occurred	00H	0
	Unrecoverable error occurred	20H	32
6	Auto recovery error not occurred	00H	0
	Auto recovery error occurred	40H	64
7	Fixed	00H	0

Bit 6: If a head overheat error is detected, the printing is stopped until the head temperature falls. At this time, bit 6 = 1.

(4) Continuous paper detector status (When n = 4 is specified)

Bit	Status	Hex.	Decimal
0	Fixed	00H	0
1	Fixed	02H	2
2	Paper found by Paper Near-end Sensor	00H	0
	Paper not found by Paper Near-end Sensor	04H	4
3	Paper found by Paper Near-end Sensor	00H	0
	Paper not found by Paper Near-end Sensor	08H	8
4	Fixed	10H	16
5	Paper found by Paper-end Sensor	00H	0
	Paper not found by Paper-end Sensor	20H	32
6	Paper found by Paper-end Sensor	00H	0
	Paper not found by Paper-end Sensor	40H	64
7	Fixed	00H	0

\* If the command is executed right after power on in error status, correct status may not be sent out.

## CT-S281

(1) Printer status (When n = 1 is specified)

Bit	Status	Hex.	Decimal
0	Fixed	00H	0
1	Fixed	02H	2
2	Fixed	00H	0
3	Online status	00H	0
	Offline status	08H	8
4	Fixed	10H	16
5	Not waiting online recovery	00H	0
	Waiting online recovery	20H	32
6	FEED switch is not pressed	00H	0
	FEED switch is pressed	40H	64
7	Fixed	00H	0

(2) Status caused by an offline condition (When n = 2 is specified)

Bit	Status	Hex.	Decimal
0	Fixed	00H	0
1	Fixed	02H	2
2	Cover closed	00H	0
	Cover open	04H	4
3	Not in paper feed state triggered by FEED switch	00H	0
	In paper feed state triggered by FEED switch	08H	8
4	Fixed	10H	16
5	Printing is not stopped because of "paper out" state	00H	0
	Printing is stopped because of "paper out" state	20H	32
6	Error not occurred	00H	0
	Error occurred	40H	64
7	Fixed	00H	0

Bit 5: When Paper Near-end sensor (option) is installed, Printing is stopped if the Paper-end detector detects a "paper out" state, or if the printer is out of paper when the Paper Near-end Sensor is enabled by ESC c 4. At this time, bit 5 = 1.

(3) Status caused by an error (when n = 3 is specified)

Bit	Status	Hex.	Decimal
0	Fixed	00H	0
1	Fixed	02H	2
2	No Mechanism error occurred. No BM detection error occurred.(only when B.M paper is selected)	00H	0
	A Mechanism error occurred. A BM detection error occurred.(only when B.M paper is selected)	04H	4
3	Auto cutter error not occurred	00H	0
	Auto cutter error occurred	08H	8
4	Fixed	10H	16
5	Unrecoverable error not occurred	00H	0
	Unrecoverable error occurred	20H	32
6	Auto recovery error not occurred	00H	0
	Auto recovery error occurred	40H	64
7	Fixed	00H	0

Bit 2: In case of MSW3-8=ON, it is generated by cover-open.

At BM/Label model, it is generated by BM/Label-error.

Bit 3: If this error occurred because of a paper jam, for example, remove the cause of the error, and then DLE ENQ n ( $1 \leq n \leq 2$ ) can be used to recover from the error. However, it is not possible to recover from any error due to a circuit problem (e.g., broken wire).

Bit 6: If a head overheat error is detected, the printing is stopped until the head temperature falls. At this time, bit 6 = 1.

## CT-S281

(4) Continuous paper detector status (When n = 4 is specified)

Bit	Status	Hex.	Decimal
0	Fixed	00H	0
1	Fixed	02H	2
2	Paper found by Paper Near-end Sensor	00H	0
	Paper not found by Paper Near-end Sensor	04H	4
3	Paper found by Paper Near-end Sensor	00H	0
	Paper not found by Paper Near-end Sensor	08H	8
4	Fixed	10H	16
5	Paper found by Paper-end Sensor	00H	0
	Paper not found by Paper-end Sensor	20H	32
6	Paper found by Paper-end Sensor	00H	0
	Paper not found by Paper-end Sensor	40H	64
7	Fixed	00H	0

Bit 2, 3: if the Paper-end detector is uninstalled, or if MSW2-8 = 0. At this time,  
bit 2, 3 = 0

Bit5, 6: When cover is open, paper end may be detected as well.

## CT-S300/CT-S310

(1) Printer status (When n = 1 is specified)

Bit	Status	Hex.	Decimal
0	Fixed	00H	0
1	Fixed	02H	2
2	Status of pin 3 of drawer kick-out connector = L	00H	0
	Status of pin 3 of drawer kick-out connector = H	04H	4
3	Online status	00H	0
	Offline status	08H	8
4	Fixed	10H	16
5	Not waiting online recovery	00H	0
	Waiting online recovery	20H	32
6	FEED switch is not pressed	00H	0
	FEED switch is pressed	40H	64
7	Fixed	00H	0

(2) Status caused by an offline condition (When n = 2 is specified)

Bit	Status	Hex.	Decimal
0	Fixed	00H	0
1	Fixed	02H	2
2	Cover closed	00H	0
	Cover open	04H	4
3	Not in paper feed state triggered by FEED switch	00H	0
	In paper feed state triggered by FEED switch	08H	8
4	Fixed	10H	16
5	Printing is not stopped because of "paper out" state	00H	0
	Printing is stopped because of "paper out" state	20H	32
6	Error not occurred	00H	0
	Error occurred	40H	64
7	Fixed	00H	0

Bit 5: Printing is stopped if the Paper-end detector detects a "paper out" state, or if the printer is out of paper when the Paper Near-end Sensor is enabled by ESC c 4. At this time, bit 5 = 1.

(3) Status caused by an error (when n = 3 is specified)

Bit	Status	Hex.	Decimal
0	Fixed	00H	0
1	Fixed	02H	2
2	No Mechanism error occurred. No BM detection error occurred.(only when BM paper is selected)	00H	0
	A Mechanism error occurred. A BM detection error occurred.(only when BM paper is selected)	04H	4
3	Auto cutter error not occurred	00H	0
	Auto cutter error occurred	08H	8
4	Fixed	10H	16
5	Unrecoverable error not occurred	00H	0
	Unrecoverable error occurred	20H	32
6	Auto recovery error not occurred	00H	0
	Auto recovery error occurred	40H	64
7	Fixed	00H	0

Bit 2: In case of MSW3-8=ON, it is generated by cover-open.

At BM/Label model, it is generated by BM/Label-error.

Bit 3: If this error occurred because of a paper jam, for example, remove the cause of the error, and then DLE ENQ n (1≤n≤2) can be used to recover from the error. However, it is not possible to recover from any error due to a circuit problem (e.g., broken wire).

Bit 6: If a head overheat error is detected, the printing is stopped until the head temperature falls. At this time, bit 6 = 1.

**CT-S300/CT-S310**

(4) Continuous paper detector status (When n = 4 is specified)

<b>Bit</b>	<b>Status</b>	<b>Hex.</b>	<b>Decimal</b>
0	Fixed	00H	0
1	Fixed	02H	2
2	Paper found by Paper Near-end Sensor	00H	0
	Paper not found by Paper Near-end Sensor	04H	4
3	Paper found by Paper Near-end Sensor	00H	0
	Paper not found by Paper Near-end Sensor	08H	8
4	Fixed	10H	16
5	Paper found by Paper-end Sensor	00H	0
	Paper not found by Paper-end Sensor	20H	32
6	Paper found by Paper-end Sensor	00H	0
	Paper not found by Paper-end Sensor	40H	64
7	Fixed	00H	0

## CT-S310II

(1) Printer status (When n = 1 is specified)

Bit	Status	Hex.	Decimal
0	Fixed	00H	0
1	Fixed	02H	2
2	Status of pin 3 of drawer kick-out connector = L	00H	0
	Status of pin 3 of drawer kick-out connector = H	04H	4
3	Online status	00H	0
	Offline status	08H	8
4	Fixed	10H	16
5	Not waiting online recovery	00H	0
	Waiting online recovery	20H	32
6	FEED switch is not pressed	00H	0
	FEED switch is pressed	40H	64
7	Fixed	00H	0

(2) Status caused by an offline condition (When n = 2 is specified)

Bit	Status	Hex.	Decimal
0	Fixed	00H	0
1	Fixed	02H	2
2	Cover closed	00H	0
	Cover open	04H	4
3	Not in paper feed state triggered by FEED switch	00H	0
	In paper feed state triggered by FEED switch	08H	8
4	Fixed	10H	16
5	Printing is not stopped because of "paper out" state	00H	0
	Printing is stopped because of "paper out" state	20H	32
6	Error not occurred	00H	0
	Error occurred	40H	64
7	Fixed	00H	0

Bit 5: Printing is stopped if the Paper-end detector detects a "paper out" state, or if the printer is out of paper when the Paper Near-end Sensor is enabled by ESC c 4. At this time, bit 5 = 1.

(3) Status caused by an error (when n = 3 is specified)

Bit	Status	Hex.	Decimal
0	Fixed	00H	0
1	Fixed	02H	2
2	No Mechanism error occurred.	00H	0
	A Mechanism error occurred.	04H	4
3	Auto cutter error not occurred	00H	0
	Auto cutter error occurred	08H	8
4	Fixed	10H	16
5	Unrecoverable error not occurred	00H	0
	Unrecoverable error occurred	20H	32
6	Auto recovery error not occurred	00H	0
	Auto recovery error occurred	40H	64
7	Fixed	00H	0

Bit 2: In case of MSW3-8=ON, it is generated by cover-open.

Bit 3: If this error occurred because of a paper jam, for example, remove the cause of the error, and then DLE ENQ n (1≤n≤2) can be used to recover from the error. However, it is not possible to recover from any error due to a circuit problem (e.g., broken wire).

Bit 6: If a head overheat error is detected, the printing is stopped until the head temperature falls. At this time, bit 6 = 1.

(4) Continuous paper detector status (When n = 4 is specified)

Bit	Status	Hex.	Decimal
0	Fixed	00H	0
1	Fixed	02H	2
2	Fixed	04H	4
3	Fixed	08H	8
4	Fixed	10H	16
5	Paper found by Paper-end Sensor	00H	0
	Paper not found by Paper-end Sensor	20H	32
6	Paper found by Paper-end Sensor	00H	0
	Paper not found by Paper-end Sensor	40H	64
7	Fixed	00H	0

## CT-S2000

(1) Printer status (When n = 1 is specified)

Bit	Status	Hex.	Decimal
0	Fixed	00H	0
1	Fixed	02H	2
2	Status of pin 3 of drawer kick-out connector = L	00H	0
	Status of pin 3 of drawer kick-out connector = H	04H	4
3	Online status	00H	0
	Offline status	08H	8
4	Fixed	10H	16
5	Not waiting online recovery	00H	0
	Waiting online recovery	20H	32
6	FEED switch is not pressed	00H	0
	FEED switch is pressed	40H	64
7	Fixed	00H	0

(2) Status caused by an offline condition (When n = 2 is specified)

Bit	Status	Hex.	Decimal
0	Fixed	00H	0
1	Fixed	02H	2
2	Cover closed	00H	0
	Cover open	04H	4
3	Not in paper feed state triggered by FEED switch	00H	0
	In paper feed state triggered by FEED switch	08H	8
4	Fixed	10H	16
5	Printing is not stopped because of "paper out" state	00H	0
	Printing is stopped because of "paper out" state	20H	32
6	Error not occurred	00H	0
	Error occurred	40H	64
7	Fixed	00H	0

Bit 5: Printing is stopped if the Paper-end detector detects a "paper out" state, or if the printer is out of paper when the Paper Near-end Sensor is enabled by ESC c 4. At this time, bit 5 = 1.

(3) Status caused by an error (when n = 3 is specified)

Bit	Status	Hex.	Decimal
0	Fixed	00H	0
1	Fixed	02H	2
2	No Mechanism error occurred. No BM/Label detection error occurred.(only when BM/Label paper is selected)	00H	0
	A Mechanism error occurred. A BM/Label detection error occurred.(only when BM/Label paper is selected)	04H	4
3	Auto cutter error not occurred	00H	0
	Auto cutter error occurred	08H	8
4	Fixed	10H	16
5	Unrecoverable error not occurred	00H	0
	Unrecoverable error occurred	20H	32
6	Auto recovery error not occurred	00H	0
	Auto recovery error occurred	40H	64
7	Fixed	00H	0

Bit 2: In case of MSW3-8=ON, it is generated by cover-open.

At BM/Label model, it is generated by BM/Label-error.

Bit 3: If this error occurred because of a paper jam, for example, remove the cause of the error, and then DLE ENQ n (1≤n≤2) can be used to recover from the error. However, it is not possible to recover from any error due to a circuit problem (e.g., broken wire).

Bit 6: If a head overheat error is detected, the printing is stopped until the head temperature falls. At this time, bit 6 = 1.



## CT-S2000

(4) Continuous paper detector status (When n = 4 is specified)

Bit	Status	Hex.	Decimal
0	Fixed	00H	0
1	Fixed	02H	2
2	Paper found by Paper Near-end Sensor	00H	0
	Paper not found by Paper Near-end Sensor	04H	4
3	Paper found by Paper Near-end Sensor	00H	0
	Paper not found by Paper Near-end Sensor	08H	8
4	Fixed	10H	16
5	Paper found by Paper-end Sensor	00H	0
	Paper not found by Paper-end Sensor	20H	32
6	Paper found by Paper-end Sensor	00H	0
	Paper not found by Paper-end Sensor	40H	64
7	Fixed	00H	0

## CT-S4000

(1) Printer status (When n = 1 is specified)

Bit	Status	Hex.	Decimal
0	Fixed	00H	0
1	Fixed	02H	2
2	Status of pin 3 of drawer kick-out connector = L	00H	0
	Status of pin 3 of drawer kick-out connector = H	04H	4
3	Online status	00H	0
	Offline status	08H	8
4	Fixed	10H	16
5	Not waiting online recovery	00H	0
	Waiting online recovery	20H	32
6	FEED switch is not pressed	00H	0
	FEED switch is pressed	40H	64
7	Fixed	00H	0

(2) Status caused by an offline condition (When n = 2 is specified)

Bit	Status	Hex.	Decimal
0	Fixed	00H	0
1	Fixed	02H	2
2	Cover closed	00H	0
	Cover open	04H	4
3	Not in paper feed state triggered by FEED switch	00H	0
	In paper feed state triggered by FEED switch	08H	8
4	Fixed	10H	16
5	Printing is not stopped because of "paper out" state	00H	0
	Printing is stopped because of "paper out" state	20H	32
6	Error not occurred	00H	0
	Error occurred	40H	64
7	Fixed	00H	0

Bit 5: Printing is stopped if the Paper-end detector detects a "paper out" state, or if the printer is out of paper when the Paper Near-end Sensor is enabled by ESC c 4. At this time, bit 5 = 1.

(3) Status caused by an error (when n = 3 is specified)

Bit	Status	Hex.	Decimal
0	Fixed	00H	0
1	Fixed	02H	2
2	No Mechanism error occurred. No BM/Label detection error occurred.(only when BM/Label paper is selected)	00H	0
	A Mechanism error occurred. A BM/Label detection error occurred.(only when BM/Label paper is selected)	04H	4
3	Auto cutter error not occurred	00H	0
	Auto cutter error occurred	08H	8
4	Fixed	10H	16
5	Unrecoverable error not occurred	00H	0
	Unrecoverable error occurred	20H	32
6	Auto recovery error not occurred	00H	0
	Auto recovery error occurred	40H	64
7	Fixed	00H	0

Bit 2: In case of MSW3-8=ON, it is generated by cover-open.

At BM/Label model, it is generated by BM/Label-error.

Bit 3: If this error occurred because of a paper jam, for example, remove the cause of the error, and then DLE ENQ n (1≤n≤2) can be used to recover from the error. However, it is not possible to recover from any error due to a circuit problem (e.g., broken wire).

Bit 6: If a head overheat error is detected, the printing is stopped until the head temperature falls. At this time, bit 6 = 1.

## CT-S4000

(4) Continuous paper detector status (When n = 4 is specified)

Bit	Status	Hex.	Decimal
0	Fixed	00H	0
1	Fixed	02H	2
2	Paper found by Paper Near-end Sensor	00H	0
	Paper not found by Paper Near-end Sensor	04H	4
3	Paper found by Paper Near-end Sensor	00H	0
	Paper not found by Paper Near-end Sensor	08H	8
4	Fixed	10H	16
5	Paper found by Paper-end Sensor	00H	0
	Paper not found by Paper-end Sensor	20H	32
6	Paper found by Paper-end Sensor	00H	0
	Paper not found by Paper-end Sensor	40H	64
7	Fixed	00H	0

**CT-S801/CT-S851/CT-S601/CT-S651**

(1) Printer status (When n = 1 is specified)

Bit	Status	Hex.	Decimal
0	Fixed	00H	0
1	Fixed	02H	2
2	Status of pin 3 of drawer kick-out connector = L	00H	0
	Status of pin 3 of drawer kick-out connector = H	04H	4
3	Online status	00H	0
	Offline status	08H	8
4	Fixed	10H	16
5	Not waiting online recovery	00H	0
	Waiting online recovery	20H	32
6	FEED switch is not pressed	00H	0
	FEED switch is pressed	40H	64
7	Fixed	00H	0

(2) Status caused by an offline condition (When n = 2 is specified)

Bit	Status	Hex.	Decimal
0	Fixed	00H	0
1	Fixed	02H	2
2	Cover closed	00H	0
	Cover open	04H	4
3	Not in paper feed state triggered by FEED switch	00H	0
	In paper feed state triggered by FEED switch	08H	8
4	Fixed	10H	16
5	Printing is not stopped because of "paper out" state	00H	0
	Printing is stopped because of "paper out" state	20H	32
6	Error not occurred	00H	0
	Error occurred	40H	64
7	Fixed	00H	0

Bit 5: Printing is stopped if the Paper-end detector detects a "paper out" state, or if the printer is out of paper when the Paper Near-end Sensor is enabled by ESC c 4. At this time, bit 5 = 1.

(3) Status caused by an error (when n = 3 is specified)

Bit	Status	Hex.	Decimal
0	Fixed	00H	0
1	Fixed	02H	2
2	No Mechanism error occurred. No BM/Label detection error occurred.(only when BM/Label paper is selected)	00H	0
	A Mechanism error occurred. A BM/Label detection error occurred.(only when BM/Label paper is selected)	04H	4
3	Auto cutter error not occurred	00H	0
	Auto cutter error occurred	08H	8
4	Fixed	10H	16
5	Unrecoverable error not occurred	00H	0
	Unrecoverable error occurred	20H	32
6	Auto recovery error not occurred	00H	0
	Auto recovery error occurred	40H	64
7	Fixed	00H	0

Bit 2: In case of MSW3-8=ON, it is generated by cover-open.

At BM/Label model, it is generated by BM/Label-error.

Bit 3: If this error occurred because of a paper jam, for example, remove the cause of the error, and then DLE ENQ n (1≤n≤2) can be used to recover from the error. However, it is not possible to recover from any error due to a circuit problem (e.g., broken wire).

Bit 6: If a head overheat error is detected, the printing is stopped until the head temperature falls. At this time, bit 6 = 1.

**CT-S801/CT-S851/CT-S601/CT-S651**

(4) Continuous paper detector status (When n = 4 is specified)

<b>Bit</b>	<b>Status</b>	<b>Hex.</b>	<b>Decimal</b>
0	Fixed	00H	0
1	Fixed	02H	2
2	Paper found by Paper Near-end Sensor	00H	0
	Paper not found by Paper Near-end Sensor	04H	4
3	Paper found by Paper Near-end Sensor	00H	0
	Paper not found by Paper Near-end Sensor	08H	8
4	Fixed	10H	16
5	Paper found by Paper-end Sensor	00H	0
	Paper not found by Paper-end Sensor	20H	32
6	Paper found by Paper-end Sensor	00H	0
	Paper not found by Paper-end Sensor	40H	64
7	Fixed	00H	0

## BD2-2220

(1) Printer status (When n = 1 is specified)

Bit	Status	Hex.	Decimal
0	Fixed	00H	0
1	Fixed	02H	2
2	Fixed	00H	0
3	Online status	00H	0
	Offline status	08H	8
4	Fixed	10H	16
5	Not waiting online recovery	00H	0
	Waiting online recovery	20H	32
6	LF-SW signal is High-Level	00H	0
	LF-SW signal is Low-Level	40H	64
7	Fixed	00H	0

(2) Status caused by an offline condition (When n = 2 is specified)

Bit	Status	Hex.	Decimal
0	Fixed	00H	0
1	Fixed	02H	2
2	Head-down	00H	0
	Head-up	04H	4
3	Not in paper feed state triggered by LF-SW signal	00H	0
	In paper feed state triggered by LF-SW signal	08H	8
4	Fixed	10H	16
5	Printing is not stopped because of "paper out" state	00H	0
	Printing is stopped because of "paper out" state	20H	32
6	Error not occurred	00H	0
	Error occurred	40H	64
7	Fixed	00H	0

Bit 5: Printing is stopped if the Paper-end detector detects a "paper out" state, or if the printer is out of paper when the Paper Near-end Sensor is enabled by ESC c 4. At this time, bit 5 = 1.

(3) Status caused by an error (when n = 3 is specified)

Bit	Status	Hex.	Decimal
0	Fixed	00H	0
1	Fixed	02H	2
2	Fixed	00H	0
3	Auto cutter error not occurred	00H	0
	Auto cutter error occurred	08H	8
4	Fixed	10H	16
5	Unrecoverable error not occurred	00H	0
	Unrecoverable error occurred	20H	32
6	Auto recovery error not occurred	00H	0
	Auto recovery error occurred	40H	64
7	Fixed	00H	0

Bit 3: If this error occurred because of a paper jam, for example, remove the cause of the error, and then DLE ENQ n (1≤n≤2) can be used to recover from the error. However, it is not possible to recover from any error due to a circuit problem (e.g., broken wire).

Bit 6: If a head overheat error is detected, the printing is stopped until the head temperature falls. At this time, bit 6 = 1.

(4) Continuous paper detector status (When n = 4 is specified)

Bit	Status	Hex.	Decimal
0	Fixed	00H	0
1	Fixed	02H	2
2	Paper found by Paper Near-end Sensor	00H	0
	Paper not found by Paper Near-end Sensor	04H	4
3	Paper found by Paper Near-end Sensor	00H	0
	Paper not found by Paper Near-end Sensor	08H	8
4	Fixed	10H	16
5	Paper found by Paper-end Sensor	00H	0
	Paper not found by Paper-end Sensor	20H	32
6	Paper found by Paper-end Sensor	00H	0
	Paper not found by Paper-end Sensor	40H	64
7	Fixed	00H	0

## PMU2XXX/PMU2XXXII

(1) Printer status (When n = 1 is specified)

Bit	Status	Hex.	Decimal
0	Fixed	00H	0
1	Fixed	02H	2
2	Fixed	00H	0
3	Online status	00H	0
	Offline status	08H	8
4	Fixed	10H	16
5	Not waiting online recovery	00H	0
	Waiting online recovery	20H	32
6	FEED switch is not pressed	00H	0
	FEED switch is pressed	40H	64
7	Fixed	00H	0

(2) Status caused by an offline condition (When n = 2 is specified)

Bit	Status	Hex.	Decimal
0	Fixed	00H	0
1	Fixed	02H	2
2	Head-down	00H	0
	Head-up	04H	4
3	Not in paper feed state triggered by FEED switch	00H	0
	In paper feed state triggered by FEED switch	08H	8
4	Fixed	10H	16
5	Printing is not stopped because of "paper out" state	00H	0
	Printing is stopped because of "paper out" state	20H	32
6	Error not occurred	00H	0
	Error occurred	40H	64
7	Fixed	00H	0

Bit 5: Printing is stopped if the Paper-end detector detects a "paper out" state, or if the printer is out of paper when the Paper Near-end Sensor is enabled by ESC c 4. At this time, bit 5 = 1.

(3) Status caused by an error (when n = 3 is specified)

Bit	Status	Hex.	Decimal
0	Fixed	00H	0
1	Fixed	02H	2
2	No Mechanism error occurred. No BM/Label detection error occurred.(only when BM/Label paper is selected)	00H	0
	A Mechanism error occurred. A BM/Label detection error occurred.(only when BM/Label paper is selected)	04H	4
3	Auto cutter error not occurred	00H	0
	Auto cutter error occurred	08H	8
4	Fixed	10H	16
5	Unrecoverable error not occurred	00H	0
	Unrecoverable error occurred	20H	32
6	Auto recovery error not occurred	00H	0
	Auto recovery error occurred	40H	64
7	Fixed	00H	0

Bit 2: In case of MSW3-8=ON, it is generated by cover-open.

At BM/Label model, it is generated by BM/Label-error.

Bit 3: If this error occurred because of a paper jam, for example, remove the cause of the error, and then DLE ENQ n (1≤n≤2) can be used to recover from the error. However, it is not possible to recover from any error due to a circuit problem (e.g., broken wire).

Bit 6: If a head overheat error is detected, the printing is stopped until the head temperature falls. At this time, bit 6 = 1.

## PMU2XXX/PMU2XXXII

(4) Continuous paper detector status (When n = 4 is specified)

Bit	Status	Hex.	Decimal
0	Fixed	00H	0
1	Fixed	02H	2
2	Paper found by Paper Near-end Sensor	00H	0
	Paper not found by Paper Near-end Sensor	04H	4
3	Paper found by Paper Near-end Sensor	00H	0
	Paper not found by Paper Near-end Sensor	08H	8
4	Fixed	10H	16
5	Paper found by Paper-end Sensor	00H	0
	Paper not found by Paper-end Sensor	20H	32
6	Paper found by Paper-end Sensor	00H	0
	Paper not found by Paper-end Sensor	40H	64
7	Fixed	00H	0



## PMU2300III

(1) Printer status (When n = 1 is specified)

Bit	Status	Hex.	Decimal
0	Fixed	00H	0
1	Fixed	02H	2
2	Fixed	00H	0
3	Online status	00H	0
	Offline status	08H	8
4	Fixed	10H	16
5	Not waiting online recovery	00H	0
	Waiting online recovery	20H	32
6	FEED switch is not pressed	00H	0
	FEED switch is pressed	40H	64
7	Fixed	00H	0

(2) Status caused by an offline condition (When n = 2 is specified)

Bit	Status	Hex.	Decimal
0	Fixed	00H	0
1	Fixed	02H	2
2	Head-down	00H	0
	Head-up	04H	4
3	Not in paper feed state triggered by FEED switch	00H	0
	In paper feed state triggered by FEED switch	08H	8
4	Fixed	10H	16
5	Printing is not stopped because of "paper out" state	00H	0
	Printing is stopped because of "paper out" state	20H	32
6	Error not occurred	00H	0
	Error occurred	40H	64
7	Fixed	00H	0

Bit 5: Printing is stopped if the Paper-end detector detects a "paper out" state, or if the printer is out of paper when the Paper Near-end Sensor is enabled by ESC c 4. At this time, bit 5 = 1.

(3) Status caused by an error (when n = 3 is specified)

Bit	Status	Hex.	Decimal
0	Fixed	00H	0
1	Fixed	02H	2
2	No Mechanism error occurred. No BM/Label detection error occurred.(only when BM/Label paper is selected) No presenter error	00H	0
	A Mechanism error occurred. A BM/Label detection error occurred.(only WhenBM/Label paper is selected) A presenter error occurred.	04H	4
3	Auto cutter error not occurred	00H	0
	Auto cutter error occurred	08H	8
4	Fixed	10H	16
5	Unrecoverable error not occurred	00H	0
	Unrecoverable error occurred	20H	32
6	Auto recovery error not occurred	00H	0
	Auto recovery error occurred	40H	64
7	Fixed	00H	0

Bit 2: In case of MSW3-8=ON, it is generated by cover-open.

At BM/Label model, it is generated by BM/Label-error.

At presenter model, it is generated by presenter error.

Bit 3: If this error occurred because of a paper jam, for example, remove the cause of the error, and then DLE ENQ n ( $1 \leq n \leq 2$ ) can be used to recover from the error. However, it is not possible to recover from any error due to a circuit problem (e.g., broken wire).

Bit 6: If a head overheat error is detected, the printing is stopped until the head temperature falls. At this time, bit 6 = 1.

### PMU2300III

(4) Continuous paper detector status (When n = 4 is specified)

Bit	Status	Hex.	Decimal
0	Fixed	00H	0
1	Fixed	02H	2
2	Paper found by Paper Near-end Sensor	00H	0
	Paper not found by Paper Near-end Sensor	04H	4
3	Paper found by Paper Near-end Sensor	00H	0
	Paper not found by Paper Near-end Sensor	08H	8
4	Fixed	10H	16
5	Paper found by Paper-end Sensor	00H	0
	Paper not found by Paper-end Sensor	20H	32
6	Paper found by Presenter Sensor	00H	0
	Paper not found by Presenter Sensor	40H	64
7	Fixed	00H	0

## CT-P29x series

(1) Printer status (When n = 1 is specified)

Bit	Status	Hex.	Decimal
0	Fixed	00H	0
1	Fixed	02H	2
2	Fixed	00H	0
3	Online status	00H	0
	Offline status	08H	8
4	Fixed	10H	16
5	Not waiting online recovery	00H	0
	Waiting online recovery	20H	32
6	FEED switch is not pressed	00H	0
	FEED switch is pressed	40H	64
7	Fixed	00H	0

(2) Status caused by an offline condition (When n = 2 is specified)

Bit	Status	Hex.	Decimal
0	Fixed	00H	0
1	Fixed	02H	2
2	Head-down	00H	0
	Head-up	04H	4
3	Not in paper feed state triggered by FEED switch	00H	0
	In paper feed state triggered by FEED switch	08H	8
4	Fixed	10H	16
5	Printing is not stopped because of "paper out" state	00H	0
	Printing is stopped because of "paper out" state	20H	32
6	Error not occurred	00H	0
	Error occurred	40H	64
7	Fixed	00H	0

Bit 5: Printing is stopped if the Paper-end detector detects a "paper out" state, or if the printer is out of paper when the Paper Near-end Sensor is enabled by ESC c 4. At this time, bit 5 = 1.

(3) Status caused by an error (when n = 3 is specified)

Bit	Status	Hex.	Decimal
0	Fixed	00H	0
1	Fixed	02H	2
2	No Mechanism error occurred.	00H	0
	A Mechanism error occurred.	04H	4
3	Auto cutter error not occurred	00H	0
	Auto cutter error occurred	08H	8
4	Fixed	10H	16
5	Unrecoverable error not occurred	00H	0
	Unrecoverable error occurred	20H	32
6	Auto recovery error not occurred	00H	0
	Auto recovery error occurred	40H	64
7	Fixed	00H	0

Bit 2: In case of MSW3-8=ON, it is generated by cover-open.

Bit 3: If this error occurred because of a paper jam, for example, remove the cause of the error, and then DLE ENQ n (1≤n≤2) can be used to recover from the error. However, it is not possible to recover from any error due to a circuit problem (e.g., broken wire).

Bit 6: If a head overheat error is detected, the printing is stopped until the head temperature falls. At this time, bit 6 = 1.

### CT-P29x series

(4) Continuous paper detector status (When n = 4 is specified)

Bit	Status	Hex.	Decimal
0	Fixed	00H	0
1	Fixed	02H	2
2	Fixed	04H	4
3	Fixed	08H	8
4	Fixed	10H	16
5	Paper found by Paper-end Sensor	00H	0
	Paper not found by Paper-end Sensor	20H	32
6	Paper found by Paper-end Sensor	00H	0
	Paper not found by Paper-end Sensor	40H	64
7	Fixed	00H	0

# ESC u n (Valid in CBM1000-Compatible Mode)

Support model	CT-S280	CT-S300	CT-S2000	CT-S4000	BD2-2220	PMU series
	CT-S281	CT-S310	CT-S801/851	CT-S601/651	CT-P29x series	CT-S310 II

**[Function]** Sending the peripheral device status

**[Code]** <1B>H<75>H<n>

**[Outline]** **[The specification which is common to the model]**

- Send the current drawer kick connector pin#3 status.
- n has the type shown in the table below:

n	Connector Pin
0	Drawer kick connector pin#3

**[Caution]** **[The specification which is common to the model]**

- Status to be sent uses 1 byte that has the value listed in the table below.
- DTR/DSR control sends 1 byte only after checking that host is ready to receive (DSR signal: space status). For XON/XOFF control, 1 byte is sent without checking DSR signal status.
- For DTR/DSR, if host is not ready to receive (DSR signal: mark status), it waits for ready condition to receive.
- Paper-end status causes BUSY status, thus this command may be in the receive-not-ready status.
- This command is valid only when MSW3-7 is set to ON.

Bit	Function	Value	
		0	1
0	Pin #3 level	'L'	'H'
1	Undefined	-	-
2	Undefined	-	-
3	Undefined	-	-
4	Unused	0: Fixed	-
5	Undefined	-	-
6	Undefined	-	-
7	Undefined	-	-

**[Sample Program]**

```
OPEN "COM1:N81NN" AS #1 -> OPEN statement depends on types of BASIC.
PRINT #1,CHR$(&H1B);"u";CHR$(0)
A$ = INPUT$(1, #1)
CLOSE #1
```

# ESC v

Support model	CT-S280	CT-S300	CT-S2000	CT-S4000	BD2-2220	PMU series
	CT-S281	CT-S310	CT-S801/851	CT-S601/651	CT-P29x series	CT-S310 II

**[Function]** Transmission of printer status

**[Code]** <1B>H<76>H

**[Outline]** **[The specification which is common to the model]**

- Transmits current printer status.

**[Caution]** **[The specification which is common to the model]**

- Status is transmitted in 1byte with the content shown in the following table.
- In case of DTR/DSR control, only 1byte is transmitted after making sure the host is ready for reception (DSR signal is in the Space state). In case of XON/XOFF control, only 1byte is transmitted without checking the status of DSR signal.
- In case of DTR/DSR, if the host is not ready for reception (DSR signal in Mark state, wait till reception is available.
- Paper-end status causes BUSY status, thus this command may be in the receive-not-ready status.
- This command is valid only when MSW3-7 is set to ON.

Bit	Position	Value	
		0	1
0	Paper Near-end	With paper	No paper
1	Undefined	-	-
2	Paper-end	With paper	No paper
3	Undefined	-	-
4	Unused	Fixed	-
5	Undefined	-	-
6	Undefined	-	-
7	Undefined	-	-

Bit 2: In case of Paper End, as this printer goes offline, this command is not executed.  
Therefore, status "No Paper (04H)" is never transmitted.

**[The specification which depend on the model]**

**CT-P29x series/CT-S310 II**

- Bit 0 is set to 00H because Paper-Near End sensor is not supported.

**[Sample Program]**

```
OPEN "COM1:N81NN" AS #1 -> OPEN statement varies with the type of BASIC.
PRINT #1, CHR$(&H1B);"V";
A$ = INPUT$(1, #1)
CLOSE #1
```

# GS a n

Support model	CT-S280	CT-S300	CT-S2000	CT-S4000	BD2-2220	PMU series
	CT-S281	CT-S310	CT-S801/851	CT-S601/651	CT-P29x series	CT-S310 II

**[Function]** Enabling/disabling ASB (Automatic Status Back)

**[Code]** <1D>H<61>H<n>

**[Range]** 0≤n≤255

**[Outline]** **[The specification which is common to the model]**

- This command selects the status item to be addressed by ASB (Automatic Status Back.)

Bit	Status Item Addressed by ASB	Hex.	Decimal
0	Status of pin 3 of drawer kick-out connector = Disabled	00H	0
	Status of pin 3 of drawer kick-out connector = Enabled	01H	1
1	Online/offline status = Disabled	00H	0
	Online/offline status = Enabled	02H	2
2	Error status = Disabled	00H	0
	Error status = Enabled	04H	4
3	Continuous Paper Sensor = Disabled	00H	0
	Continuous Paper Sensor = Enabled	08H	8
4	Undefined	-	-
5	Undefined	-	-
6	Undefined	-	-
7	Undefined	-	-

**[Caution]** **[The specification which is common to the model]**

- If any status item is enabled, the status is sent to the host when this command is executed. After that time on, the status is sent each time an enabled status item changes. Because each status item represents the current condition, status items disabled for ASB may also have changed.
- The ASB function is disabled if all status items are disabled.
- If the ASB function is enabled by default, the host receives the status the first time the printer gets ready for communication after it is turned on.
- The printer sends 4 bytes of status shown in the tables below, without checking whether the host is ready to receive or busy. The 4 bytes of status is a continuous string except for XOFF code.
- Because this command is executed when data is mapped in the receive buffer, there may be a delay between command receiving and status sending depending on the condition of the receive buffer.
- Even if the printer is excluded from the selection of peripheral equipment ESC =, the 4 bytes of status is sent to the host whenever status changes.
- When DLE EOT, GS I, or GS r is used, the host must discriminate between the status specified by these commands and the status due to ASB.

**[The specification which depend on the model]**

**CT-S280/CT-S281/BD2-2220/PMU series/CT-P29x series**

- Bit 2 of the 1st byte (printer information) of the status sent in 4 bytes is set to 00H because drawer is not supported.

**PMU2300III**

- If the presenter function is valid, Bit 2 of the 2nd byte sent in 4 bytes status data is set to 04H when presenter error occurs.
- If the presenter function is valid, Bit 3 of the 3rd byte sent in 4 bytes shows presenter sensor status.

**CT-S281**

- Bit 0, 1 of the 3rd byte (Paper Sensor information) is set to 00H, if the Paper-end detector is uninstalled, or if MSW2-8= 0.
- Bit 2, 3 of the 3<sup>rd</sup> byte (Paper Sensor information): When cover is open, paper end may be detected as well.

**CT-P29x series/CT-S310 II**

- Bit 0, 1 of the 3<sup>rd</sup> byte (Paper Sensor information): Bit is fixed at 0 due to no paper near end function.

(1) 1st byte (Printer information)

Bit	Status	Hex.	Decimal
0	Unused	00H	0
1	Unused	00H	0
2	Status of pin 3 of drawer kick-out connector = "L"	00H	0
	Status of pin 3 of drawer kick-out connector = "H"	04H	4
3	Online status	00H	0
	Offline status	08H	8
4	Unused	10H	16
5	Cover closed	00H	0
	Cover open	20H	32
6	Not in paper feed state triggered by FEED switch	00H	0
	In paper feed state triggered by FEED switch	40H	64
7	Unused	00H	0



## (2) 2nd byte (Error occurrence information)

Bit	Status	Hex.	Decimal
0	Undefined	-	-
1	Undefined	-	-
2	No Mechanism error occurred. No BM detection error occurred.(only when BM paper is selected) No presenter error occurred. (only when presenter function is enabled.)	00H	0
	A Mechanism error occurred. A BM detection error occurred.(only when BM paper is selected) A presenter error occurred (only when presenter function is enabled.)	04H	4
3	Auto cutter error not occurred	00H	0
	Auto cutter error occurred	08H	8
4	Unused	00H	0
5	Unrecoverable error not occurred	00H	0
	Unrecoverable error occurred	20H	32
6	Auto recovery error not occurred	00H	0
	Auto recovery error occurred	40H	64
7	Unused	00H	0

\*Bit 2: In case of MSW3-8=ON, it is generated by cover-open.

At BM/Label model, it is generated by BM/Label-error.

At presenter model, it is generated at presenter error.

\*Bit 3: If this error occurred because of a paper jam, for example, remove the cause of the error, and then DLE ENQ n (1 n 2) can be used to recover from the error. However, it is not possible to recover from any error due to a circuit problem (e.g., broken wire).

\*Bit 6: If a head overheat error is detected, the printing is stopped until the head temperature falls. At this time, bit 6 = 1.

## (3) 3rd byte (Paper Sensor information)

Bit	Status	Hex.	Decimal
0, 1	Paper found by Paper Near-end Sensor	00H	0
	Paper not found by Paper Near-end Sensor	03H	3
2, 3	Paper found by Paper-end Sensor	00H	0
	Paper not found by Paper-end Sensor	0CH	12
4	Unused	00H	0
5	Undefined	-	-
6	Undefined	-	-
7	Unused	00H	0

(3) 3rd byte (Paper Sensor information) **PMU2300III**

Bit	Status	Hex.	Decimal
0, 1	Paper found by Paper Near-end Sensor	00H	0
	Paper not found by Paper Near-end Sensor	03H	3
2	Paper found by Paper-end Sensor	00H	0
	Paper not found by Paper-end Sensor	04H	4
3	Paper not found by Presenter Sensor	00H	0
	Paper found by Presenter Sensor	08H	8
4	Unused	00H	0
5	Undefined	-	-
6	Undefined	-	-
7	Unused	00H	0

(4) 4th byte (Paper Sensor information)

In case of MSW3-7 ON

Bit	Status	Hex.	Decimal
0	Undefined	-	-
1	Undefined	-	-
2	Undefined	-	-
3	Undefined	-	-
4	Unused	00H	0
5	Undefined	-	-
6	Undefined	-	-
7	Unused	00H	0

In case of MSW3-7 OFF (CBM1000 non-compatible mode)

Bit	Status	Hex.	Decimal
0	Reserved	01H	1
1	Reserved	02H	2
2	Reserved	04H	4
3	Reserved	08H	8
4	Fixed	00H	0
5	Reserved	00H	00
6	Reserved	00H	00
7	Fixed	00H	0

**[Default]** When MSW 1-3 OFF : n=0  
When MSW 1-3 ON : n=2

**[The specification which depend on the model]**

**CT-S801/CT-S851/CT-S601/CT-S651/CT-S310 II**

MSW1-3 OFF/MSW6-1 OFF: n=0  
MSW1-3 ON /MSW6-1 OFF: n=2  
MSW1-3 OFF/MSW6-1 ON : n=15  
MSW1-3 ON /MSW6-1 ON : n=15

**[See Also]** [DLE EOT, GSr](#)

# GS r n

Support model	CT-S280	CT-S300	CT-S2000	CT-S4000	BD2-2220	PMU series
	CT-S281	CT-S310	CT-S801/851	CT-S601/651	CT-P29x series	CT-S310 II

**[Function]** Sending status

**[Code]** <1D>H<72>H<n>

**[Range]** **[The specification which depend on the model]**  
**CT-S280/CT-S281/BD2-2220/PMU series/CT-P29x series**  
 n=1, 49  
**CT-S300/CT-S310/CT-S2000/CT-S4000**  
**CT-S801/CT-S851/CT-S601/CT-S651/CT-S310 II**  
 1≤n≤2, 49≤n≤50

**[Outline]** **[The specification which is common to the model]**

- Sends the specified status to the host.

n	Function
1, 49	Sends the Paper Sensor status.
2, 50	Sends the Drawer Kick-out Connector status.

**[Caution]** **[The specification which is common to the model]**

- When the serial interface is used:
  - For DTR/DSR control:
    - The printer sends the status after verifying that the host is ready to receive. If the host is not ready to receive, the printer waits for the host to become ready to receive.
  - For XON/XOFF control:
    - The printer sends the status without checking whether the host is ready to receive or busy.
- Because this command is executed when data is mapped in the receive buffer, there may be a delay between receiving the command and sending the status depending on the condition of the receive buffer.
- If ASB (Automatic Status Back) is enabled by GS a, the host must discriminate between the status due to this command and the status due to ASB.
- Whenever the Paper-end Sensor detects a "paper out" state, the printer goes offline, and the command is not executed. Therefore, the printer never sends a status "No paper in Paper-end detector (0CH)".

**[The specification which depend on the model]**  
**CT-S280/CT-S281/BD2-2220/PMU series/CT-P29x series**

- At the setting of MSW3-7 OFF, paper sensor status is fixed to 00h.

**[The specification which depend on the model]**  
**CT-P29x series/CT-S310 II**

- Status bit 0 is fixed at 0 due to no paper near end function.

- Paper Sensor status (n=1, 49)

Bit	Status	Hex.	Decimal
0, 1	Paper found by Paper Near-end Sensor	00H	0
	Paper not found by Paper Near-end Sensor	03H	3
2, 3	Paper found by Paper-end Sensor	00H	0
	Paper not found by Paper-end Sensor	(0CH)	(12)
4	Unused	00H	0
5	Undefined	-	-
6	Undefined	-	-
7	Unused	00H	0

- Drawer kick-out connector status (n=2, 50)

Bit	Status	Hex.	Decimal
0	Status of pin 3 of drawer kick connector = "L"	00H	0
	Status of pin 3 of drawer kick connector = "H"	01H	1
1	Undefined	-	-
2	Undefined	-	-
3	Undefined	-	-
4	Unused	00H	0
5	Undefined	-	-
6	Undefined	-	-
7	Unused	00H	0

**[See Also]** [Appendix 5.3 "Identification of Send Status"](#)  
[DLE EOT, GS a](#)

## 2.2.8 Paper Detecting Commands

# ESC c 3 n

Support model	CT-S280	CT-S300	CT-S2000	CT-S4000	BD2-2220	PMU series
	CT-S281	CT-S310	CT-S801/851	CT-S601/651	CT-P29x series	CT-S310 II

**[Function]** Selecting the Paper Sensor valid for a Paper-end signal output

**[Code]** <1B>H<63>H<33>H<n>

**[Range]** 0≤n≤255

**[Outline]** **[The specification which is common to the model]**

- This command selects by which Paper Sensor a Paper-end signal should be output. Each bit for "n" has the following meaning:

Bit	Position	Value	
		0	1
0	Paper Near-end	Disabled	Enabled
1	Paper Near-end	Disabled	Enabled
2	Paper-end	Disabled	Enabled
3	Paper-end	Disabled	Enabled
4	Undefined	—	—
5	Undefined	—	—
6	Undefined	—	—
7	Undefined	—	—

**[Caution]** **[The specification which is common to the model]**

- This command is valid only for the parallel interface.

**[Default]** **[The specification which depend on the model]**

CT-S280/CT-S281/CT-S300/CT-S310/ CT-S2000/CT-S4000  
BD2-2220/PMU series

n=15

CT-P29x series/CT-S301II

n=15 (no signal at paper near end due to no paper near end sensor)

CT-S801/CT-S851/CT-S601/CT-S651

- MSW3-2 OFF: n=15
- MSW3-2 ON : n=12

# ESC c 4 n

Support model	CT-S280	CT-S300	CT-S2000	CT-S4000	BD2-2220	PMU series
	CT-S281	CT-S310	CT-S801/851	CT-S601/651	CT-P29x series	CT-S310 II

**[Function]** Selecting the Paper Near-end Sensor valid for print stop

**[Code]** <1B>H<63>H<34>H<n>

**[Range]** 0≤n≤255

**[Outline]** **[The specification which is common to the model]**

- This command selects the Paper Near-end Sensor which helps to stop printing when the paper supply almost runs out.
- Each bit for "n" has the following meaning:

Bit	Position	Value	
		0	1
0	Paper Near-end	Disabled	Enabled
1	Paper Near-end	Disabled	Enabled
2	Undefined	-	-
3	Undefined	-	-
4	Undefined	-	-
5	Undefined	-	-
6	Undefined	-	-
7	Undefined	-	-

**[The specification which depend on the model]**

**CT-P29x series/CT-S301II**

- This command is invalid due to no paper near end sensor.

**[Caution]** **[The specification which is common to the model]**

- This printer can only select one kind of Paper Sensor, a Paper Near-end Sensor.

**[Default]** n=0

## 2.2.9 Panel Switch Commands

# ESC c 5 n

Support model	CT-S280	CT-S300	CT-S2000	CT-S4000	BD2-2220	PMU series
	CT-S281	CT-S310	CT-S801/851	CT-S601/651	CT-P29x series	CT-S310 II

**[Function]** Enabling/disabling the panel switches

**[Code]** <1B>H<63>H<35>H<n>

**[Range]** 0≤n≤255

**[Outline]** **[The specification which is common to the model]**

- Enabling/disabling the FEED switch.
- "n" is valid only for the lowest bit (n0).
- Control by the lowest bit (n0) is shown as follows:

n0	Condition
0	FEED switch (LF-SW signal) valid
1	FEED switch (LF-SW signal) invalid

**[Caution]** **[The specification which is common to the model]**

- When the FEED switch is disabled with this command, the paper cannot be fed by operating the FEED switch.
- While switch operation is waited at the execution of macro, the FEED switch is always enabled regardless of the setting of this command but no paper feed operation is carried out.

**[Default]** n=0

### CT-S801/CT-S851

- MSW3-2 OFF: n=0
- MSW3-2 ON : n=1

**[Sample Program]**

LPRINT CHR\$(&H1B);"c5";CHR\$(0); — When enabling the FEED switch

LPRINT CHR\$(&H1B);"c5";CHR\$(1); — When disabling the FEED switch

## 2.2.10 Macro Commands

# GS :

Support model	CT-S280	CT-S300	CT-S2000	CT-S4000	BD2-2220	PMU series
	CT-S281	CT-S310	CT-S801/851	CT-S601/651	CT-P29x series	CT-S310 II

**[Function]** Starting/ending macro definition

**[Code]** <1D>H<3A>H

**[Outline]** **[The specification which is common to the model]**

- Specifying starting/ending macro definition.
- Reception of this command during macro definition signifies ending the macro definition.

**[Caution]** **[The specification which is common to the model]**

- Maximum content available for macro definition is 2048 bytes. A portion exceeding 2048 bytes is not defined.
- When GS ^ is processed in macro definition, the macro definition is stopped and the content of definition is cleared.
- Even with ESC @ (Initialization of the printer) having been executed, defined content is not cleared. Therefore, it is possible to include ESC @ into the content of macro definition.
- Normal printing operation is carried out even during macro definition.

**[Default]** The initial value is not defined.

**[See Also]** [GS ^](#)

**[Sample Program]**

```
LPRINT CHR$(&H1D);";";
LPRINT "+——+";CHR$(&HA);
LPRINT "| |"; CHR$(&HA);
LPRINT "+——+"; CHR$(&HA);
LPRINT CHR$(&H1D);";";
LPRINT CHR$(&H1D);"^";
LPRINT CHR$(2); CHR$(10); CHR$(0);
```

**[Print Results]**

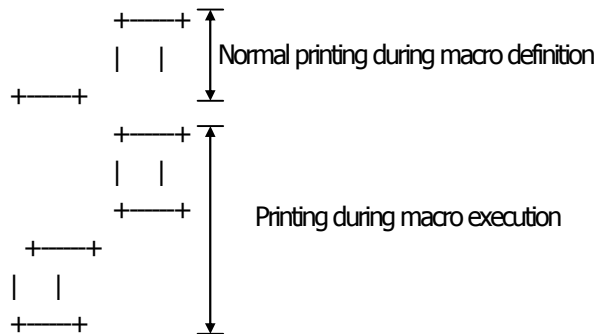



# GS ^ n1 n2 n3

Support model	CT-S280	CT-S300	CT-S2000	CT-S4000	BD2-2220	PMU series
	CT-S281	CT-S310	CT-S801/851	CT-S601/651	CT-P29x series	CT-S310 II

**[Function]** Executing the macro

**[Code]** <1D>H<5E>H<n1><n2><n3>

**[Range]** 0≤n1≤255  
0≤n2≤255  
0≤n3≤1

**[Outline]** **[The specification which is common to the model]**

- Executing contents defined in macro.
- n1 : The number of times of macro execution
- n2 : Waiting time on macro execution: Waiting time of n2 x 100 msec is given for every execution.
- n3 : Macro execution mode
  - n3 = 0 Continuous execution: The Macro is executed "n1" times continuously at the time interval specified by "n2".
  - n3 = 1 Execution by FEED Switch: After waiting for the time specified by "n2", the ARARM LED flickers and the FEED switch is waiting to be pressed. When it is pressed, the macro is executed once. This action is repeated "n1" times.

**[Caution]** **[The specification which is common to the model]**

- When this command is received while in macro definition, suspension of macro definition is indicated. At this time, the defined content is cleared.
- No execution takes place when the macro is held undefined.
- While in macro execution with n3 = 1, paper feed with the FEED switch is not available.
- When MSW2-3 ON Spool print valid is specified, n2 is invalid.

**[See Also]** [GS:](#)

**[Sample Program]**

[Refer to Sample Program and Print Results for GS:](#)

## 2.2.11 Cutter Commands

# ESC i

Support model	CT-S280	CT-S300	CT-S2000	CT-S4000	BD2-2220	PMU series
	CT-S281	CT-S310	CT-S801/851	CT-S601/651	CT-P29x series	CT-S310 II

**[Function]** Full cutting of paper

**[Code]** <1B>H<69>H

**[Outline]** **[The specification which is common to the model]**

- Executes full cutting of paper.

**[Caution]** **[The specification which is common to the model]**

- This command only works if it is entered at the beginning of a line.
- Before cutting paper, feed the paper more than the cutting position of paper from the print position. Without this paper feeding, the character just after printing remains before the cutter.

MSW4-8=ON: This command works as partial cut command.

**[The specification which depend on the model]**

CT-S281/CT-S300/CT-S310/CT-S2000/CT-S4000/  
CT-S801/CT-S851/CT-S601/CT-S651/PMU series

- With label- or BM-supported model, this command does not function at the setting of BM paper/label paper setting.

**[Sample Program]**

```
LPRINT "AAAAA";
LPRINT CHR$(&H1B);"J";
LPRINT CHR$(150);
LPRINT CHR$(&H1B);"I";
```

**[Print Results]**

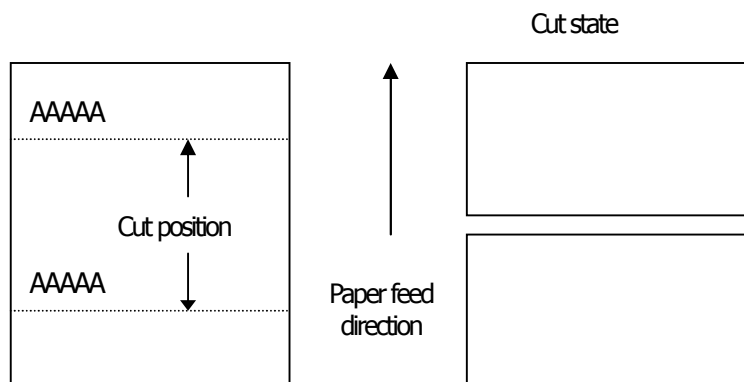

# ESC m

Support model	CT-S280	CT-S300	CT-S2000	CT-S4000	BD2-2220	PMU series
	CT-S281	CT-S310	CT-S801/851	CT-S601/651	CT-P29x series	CT-S310 II

**[Function]** Partial cutting of paper

**[Code]** <1B>H<6D>H

**[Outline]** **[The specification which is common to the model]**

- Executes partial cutting of paper.

**[Caution]** **[The specification which is common to the model]**

- This command only works if it is entered at the beginning of a line.
- Before cutting paper, feed the paper more than the cutting position of paper from the print position. Without this paper feeding, the character just after printing remains before the cutter.

**[The specification which depend on the model]**

**CT-S281/CT-S300/CT-S310/CT-S2000/CT-S4000/CT-S801/CT-S851**  
**CT-S601/CT-S651/PMU series**

- With label- or BM-supported model, this command does not function at the setting of BM paper/label paper setting.

**PMU2300III**

- When presenter function is enabled, cut method is automatically set for full cut.

**[Sample Program]**

```
LPRINT "AAAAA";
LPRINT CHR$(&H1B);"J";
LPRINT CHR$(150);
LPRINT CHR$(&H1B);"m";
```

**[Print Results]**

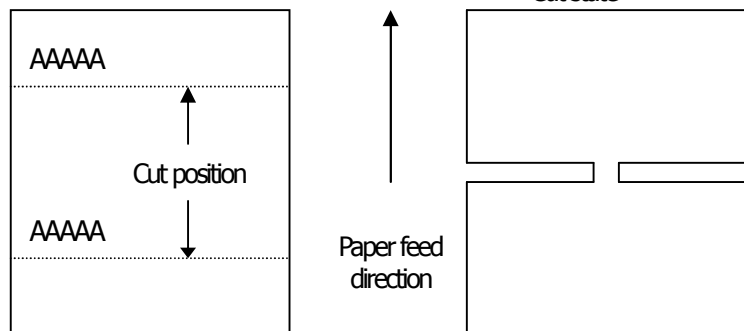

# GS V m --- (1)

# GS V m n --- (2)

Support model	CT-S280	CT-S300	CT-S2000	CT-S4000	BD2-2220	PMU series
	CT-S281	CT-S310	CT-S801/851	CT-S601/651	CT-P29x series	CT-S310 II

**[Function]** Cutting the paper

**[Code]** (1)<1D>H<56>H<m>  
(2)<1D>H<56>H<m><n>

**[Range]** (1)0≤m≤1, 48≤m≤49  
(2)m=65, 66  
0≤n≤255

**[Outline]** **[The specification which is common to the model]**

- Performs the specified paper cutting.

m	Function
0, 48	Full cut
1, 49	Partial cut (Leaving a bridge area uncut)
65	Paper feed by "cut position + {n×basic calculation pitch}" and full cut
66	Paper feed by "cut position + {n×basic calculation pitch}" and partial cut

**[Caution]** **[The specification which is common to the model]**

- In STANDARD MODE, this command only works when it is entered at the beginning of a line.
- Control to make the length of cut paper less than 10 mm is not executed.

For (1):

- Executes cutting of paper.

For (2):

- If n = 0, the paper is fed to the cut position, and then cut. If n ≠ 0, the paper is fed by "n x basic calculation pitch" inches past the cut position, and then cut.
- The basic calculation pitch is set by GS P. The paper feed amount is calculated with the vertical basic calculation pitch (y). A fraction resulting from the calculation is corrected with the minimum pitch of the mechanism, and the remainder is omitted.

MSW4-8=ON: This command works as partial cut command only.

**[The specification which depend on the model]**

**CT-S281/CT-S300/CT-S310/CT-S2000/CT-S4000/CT-S801/CT-S851**  
**CT-S601/CT-S651/PMU series**

- With label- or BM-supported model, this command does not function at the setting of BM paper/label paper setting.

**PMU2300III**

- When presenter function is enabled, cut method is automatically set for full cut.

## 2.2.12 Bar Code Commands

# GS H n

Support model	CT-S280	CT-S300	CT-S2000	CT-S4000	BD2-2220	PMU series
	CT-S281	CT-S310	CT-S801/851	CT-S601/651	CT-P29x series	CT-S310 II

**[Function]** Selecting of printing position of HRI characters

**[Code]** <1D>H<48>H<n>

**[Range]** 0≤n≤3, 48≤n≤51

**[Outline]** **[The specification which is common to the model]**

- Selecting printing position of HRI characters in printing bar codes.
- "n" means the followings.

n	Printing Position
0, 48	No printing
1, 49	Above the bar code
2, 50	Below the bar code
3, 51	Both above and below the bar code

The HRI characters refer to the bar code-turned characters so that you can read them.

**[Default]** n=0

**[See Also]** [GS f](#), [GS k](#)

### [Sample Program]

```
LPRINT CHR$(&H1B);"3"; CHR$(5);
LPRINT CHR$(&H1D);"h"; CHR$(50);
LPRINT CHR$(&H1D);"H"; CHR$(0);
GOSUB BC
LPRINT CHR$(&H1D);"H"; CHR$(1);
GOSUB BC
LPRINT CHR$(&H1D);"H"; CHR$(2);
GOSUB BC
LPRINT CHR$(&H1D);"H"; CHR$(3);
GOSUB BC
END
BC:
LPRINT CHR$(&H1D);"k";
LPRINT CHR$(4);
LPRINT "12"; CHR$(0);
LPRINT CHR$(&HA);
RETURN
```

### [Print Results]



# GS f n

Support model	CT-S280	CT-S300	CT-S2000	CT-S4000	BD2-2220	PMU series
	CT-S281	CT-S310	CT-S801/851	CT-S601/651	CT-P29x series	CT-S310 II

**[Function]** Selecting the font of HRI characters

**[Code]** <1D>H<66>H<n>

**[Range]** 0≤n≤2, 48≤n≤50

**[Outline]** **[The specification which is common to the model]**

- Selecting the font of HRI characters in printing bar code.
- The type of font can be selected with "n" as follows:

**[The specification which depend on the model]**

**CT-S300/CT-S310/CT-S801/CT-S851/CT-S601/CT-S651/ CT-P29x series**

n	Font
0, 48	Font A (12×24)
1, 49	Font B (9 ×17)
2, 50	Font C (8 ×16)

**CT-S280/CT-S281/CT-S2000/CT-S4000/BD2-2220/PMU series/ CT-S301II**

n	Font
0, 48	Font A (12×24)
1, 49	Font B (9 ×24)
2, 50	Font C (8 ×16)

**[Caution]** **[The specification which is common to the model]**

- The HRI characters are printed at the position specified with GS H.

**[Default]** n=0

**[See Also]** [GSH](#)

**[Sample Program]**

**[Print Results]**

```
LPRINT CHR$(&H1D);"h"; CHR$(50);
LPRINT CHR$(&H1D);"H"; CHR$(2);
LPRINT CHR$(&H1D);"f"; CHR$(0);
GOSUB BC
LPRINT CHR$(&H1D);"F"; CHR$(1);
GOSUB BC
END
BC:
LPRINT CHR$(&H1D);"k";
LPRINT CHR$(4);
LPRINT "12"; +CHR$(0);
LPRINT CHR$(&HA);
RETURN
```



← FONT A



← FONT B

# GS h n

Support model	CT-S280	CT-S300	CT-S2000	CT-S4000	BD2-2220	PMU series
	CT-S281	CT-S310	CT-S801/851	CT-S601/651	CT-P29x series	CT-S310 II

**[Function]** Specifying the height of the bar code

**[Code]** <1D>H<68>H<n>

**[Range]**  $1 \leq n \leq 255$

**[Outline]** **[The specification which is common to the model]**

- Selecting bar code height.
- "n" denotes the number of dots in the vertical direction.

**[Sample Program]**

[Refer to Sample Program and Print Results for GS w.](#)

# (1)GS k m [d1...dk] NUL

## (2)GS k m n [d1...dn]

Support model	CT-S280	CT-S300	CT-S2000	CT-S4000	BD2-2220	PMU series
	CT-S281	CT-S310	CT-S801/851	CT-S601/651	CT-P29x series	CT-S310 II

**[Function]** Printing the bar code

**[Code]** (1)<1D>H<6B>H<m> [d1...dk] NUL  
(2)<1D>H<6B>H<m><n> [d1...dn]

**[Range]** (1)0≤m≤6 The definitions of "k" and "d" vary with the bar code system.

**[The specification which depend on the model]**

CT-S280 /CT-S281/CT-S300/CT-S310/CT-S2000/CT-S4000/  
BD2-2220/PMU series/CT-P29x series

(2)65≤m≤73 The definitions of "n" and "d" vary with the bar code system.

CT-S801/CT-S851/CT-S601/CT-S651/CT-S310 II

(2)65≤m≤73, 75≤m≤78 The definitions of "n" and "d" vary with the bar code system.

**[Outline]** **[The specification which is common to the model]**

- Selects a bar code system and prints the bar code.

For (1):

m	Bar Code System	Range of "k"	Range of "d"
0	UPC-A	11≤k≤12	48≤d≤57
1	UPC-E	11≤k≤12	48≤d≤57
2	JAN13(EAN)	12≤k≤13	48≤d≤57
3	JAN8(EAN)	7≤k≤8	48≤d≤57
4	CODE39	1≤k	48≤d≤57, 65≤d≤90 32, 36, 37, 43, 45, 46, 47
5	ITF	1≤k (An even number)	48≤d≤57
6	CODABAR	1≤k	48≤d≤57, 65≤d≤68 36, 43, 45, 46, 47, 58

For (2):

m	Bar Code System	Range of "n"	Range of "d"
65	UPC-A	11≤n≤12	48≤d≤57
66	UPC-E	11≤n≤12	48≤d≤57
67	JAN13(EAN)	12≤n≤13	48≤d≤57
68	JAN8(EAN)	7≤n≤8	48≤d≤57
69	CODE39	1≤n≤255	48≤d≤57, 65≤d≤90 32, 36, 42, 43, 45, 46, 47
70	ITF	1≤n≤255 (An even number)	48≤d≤57
71	CODABAR	1≤n≤255	48≤d≤57, 65≤d≤68 36, 43, 45, 46, 47, 58
72	CODE93	1≤n≤255	0≤d≤127
73	CODE128	2≤n≤255	0≤d≤127
75	GS1 DataBar mndirectional	n=13	48≤d≤57
76	GS1 DataBar Truncated	n=13	48≤d≤57
77	GS1 DataBar Limited	n=13	48≤d≤57
78	GS1 DataBar Expanded	2≤n≤255	0≤d≤127



**[Caution]**

For (1):

- This command ends with a NULL code.
- For UPC-A or UPC-E, the bar code is printed when 12 bytes of bar code data have been entered, and the subsequent data is handled as normal data.
- For JAN13, the bar code is printed when 13 bytes of bar code data have been entered, and the subsequent data is handled as normal data.
- For JAN8, the bar code is printed when 8 bytes of bar code data have been entered, and the subsequent data is handled as normal data.
- The data of ITF bar code must have an even number of columns. Should the data have an odd number of columns, the last column is ignored.

For (2):

- Numeral "n" indicates the number of data items, and the subsequent "n" bytes of data are handled as bar code data.
- If "n" is out of the range, the processing of the command is aborted, and the subsequent data is handled as normal data.

For STANDARD MODE:

- If "d" is out of the range, only a paper feed is executed, and the subsequent data is handled as normal data.
- If the bar code is wider than the print area for one line, the bar code is not printed, but only a paper feed is executed.
- The amount of paper feed corresponds to the height of the bar code (including the HRI characters if HRI character printing is specified), irrespective of the line feed width set by a command such as ESC 2 or ESC 3.
- This command only works if no data exists in the print buffer. If any data exists in the print buffer, the data subsequent to "m" is handled as normal data.
- After the bar code is printed, the beginning of the line is taken as the start position for the next print.
- This command is not affected by any print modes (emphasis, double strike, underline, and character size), except for the inverted character mode.

For PAGE MODE:

- This command only maps the bar code, without performing a printout. After the bar code is mapped, the dot next to the last data item of the bar code is taken as the start position for the next data mapping.
- If "d" is out of the range, the processing of the command is aborted, and the subsequent data is handled as normal data. In this case, the data mapping start position does not move.
- If the bar code is wider than the print area, the bar code is not printed, but the data mapping start position is moved to the left end of the non-print area.

## [Description of Bar Codes]

- UPC-A** This bar code, consisting of numerals only, has a fixed length of 12 columns; a 11- column number entered from the host or application software plus a check digit (12th column) automatically calculated inside the printer. If the 12th-column numeral is sent from the host, the entire bar code will be printed as it is.
- UPC-E** This bar code, consisting of numerals only, has a fixed length of 8 columns. This printer compresses the 11- or 12-digit data (with check digit) entered to 8 digits by using zero suppression of UPC-E standard and then prints the data. Indicates an example of data compression based on zero suppression.  
\*The printer does not print bar code except the following conditions.
- Ex.) Original code shall be (0-ABCDE-VWXYZ)...11 digits (with no check digit specified).  
Printable patterns are as follows:
1. When V - Y are all "0": "0-ABCDE-0000Z"⇒"ABCDEZ".  
\*Provided only 5 - 9 are applied to Z.
  2. When E and VWXY are all "0": "0-ABCD0-0000Z"⇒"ABCDZ4".  
\*The last character 4 indicates that maker codes A and D are not "0".
  3. When DE and VWX are "0": "0-ABC00-000YZ"⇒"ABCYZ3".  
\*The last character 3 indicates that A and C are not "0" and ABC is a number of 3 digits.
  4. When DE and VW are "0" and C is "0", "1", or "2":  
(1)When C="0": "0-AB000-00XYZ"⇒"ABXYZ0".  
(2)When C="1": "0-AB100-00XYZ"⇒"ABXYZ1".  
(3)When C="2": "0-AB200-00XYZ"⇒"ABXYZ2".
  5. The check digit of 12th column is automatically calculated in the printer.
- JAN-13(EAN)** This bar code, consisting of numerals only, has a fixed length of 13 columns; a 12- column number entered from the host or application software plus a check digit (13th column) automatically calculated inside the printer. If the 13th-column numeral is sent from the host, the entire bar code will be printed as it is.
- JAN-8(EAN)** This bar code, consisting of numerals only, has a fixed length of 8 columns; a 7- column number entered from the host or application software plus a check digit (8<sup>th</sup> column) automatically calculated inside the printer. If the 8th-column numeral is sent from the host, the entire bar code will be printed as it is.
- CODE39** This bar code, consisting of upper-case alphabetic characters and numerals, has a variable length of columns. The start/stop code "\*" is automatically added by the printer. The available characters include space and "\$ % + - . / 0 1 2 3 4 5 6 7 8 9" and upper-case alphabetic characters.
- ITF** This bar code, consisting of only numerals, has a variable length of even-number columns. If a code of odd-number columns is sent, the bar code will not be printed.
- CODABAR(NW-7)** This bar code, consisting of alphanumeric, has a variable length of columns. Available characters include "0 1 2 3 4 5 6 7 8 9 A B C D \$ + - . / :". A start/stop code is required; any one of A, B, C, and D is used.

**CODE93**

This bar code, consisting of alphanumeric and control characters, has a variable length of columns. The HRI character string is preceded and followed by a "■" character. HRI characters for control characters (00H - 1FH, and 7FH) are each printed as a combination of a "■" character and an alphabetic character.

Control Character		HRI Character	Control Character		HRI Character
ASCII	Hex.		ASCII	Hex.	
NUL	00H	■U	DLE	10H	■P
SOH	01H	■A	DC1	11H	■Q
STX	02H	■B	DC2	12H	■R
ETX	03H	■C	DC3	13H	■S
EOT	04H	■D	DC4	14H	■T
ENQ	05H	■E	NAK	15H	■U
ACK	06H	■F	SYN	16H	■V
BEL	07H	■G	ETB	17H	■W
BS	08H	■H	CAN	18H	■X
HT	09H	■I	EM	19H	■Y
LF	0AH	■J	SUB	1AH	■Z
VT	0BH	■K	ESC	1BH	■A
FF	0CH	■L	FS	1CH	■B
CR	0DH	■M	GS	1DH	■C
SO	0EH	■N	RS	1EH	■D
SI	0FH	■O	US	1FH	■E
			DEL	7FH	■T

## CODE128

This bar code consists of 103 bar code characters and three code sets, enabling 128 ASCII code characters to be printed. It has a variable length of columns.

- Code set A ASCII characters 00H - 5FH can be represented.
- Code set B ASCII characters 20H - 7FH can be represented.
- Code set C Two-digit numbers 00 - 99 can each be represented by one character.

In addition to the above characters, special characters are available:

- Shift character (SHIFT)

When used in code set A, one character next to a Shift character is treated as a character of code set B.

When used in code set B, one character next to a Shift character is treated as a character of code set A.

The Shift character cannot be used in code set C.

- Code set select characters (CODE A, CODE B, CODE C):

The code set following a code set select character is switched to code set A, B, or C.

- Function characters (FNC1, FNC2, FNC3, FNC4):

How the function characters are used depends on each application. In code set C, only FNC1 is available.

When sending print data, note these points:

- (1) Each string of bar code data must begin with a code set select character (CODE A, CODE B, or CODE C), which selects the first code set to use.
- (2) Every special character is specified by a combination of two characters: a brace "{" followed by one character. A brace "{" itself is sent twice consecutively.

### Special characters

Hex.	ASCII	Code Set A	Code Set B	Code Set C
7B53H	{S	SHIFT	SHIFT	-N/A
7B41H	{A	-N/A	CODE A	CODE A
7B42H	{B	CODE B	-N/A	CODE B
7B43H	{C	CODE C	CODE C	-N/A
7B31H	{1	FNC1	FNC1	FNC1
7B32H	{2	FNC2	FNC2	-N/A
7B33H	{3	FNC3	FNC3	-N/A
7B34H	{4	FNC4	FNC4	-N/A
7B7BH	{{	`{`	`{`	`{`

<Example>

To print "No." in code set B, followed by "123456" in code set C, send the following data string:

GS k <73> <10> <7B>H <42>H "No." <7B>H <43>H <12> <34> <56>

### [Sample Program]

```
LPRINT CHR$(&H1D);"k"; CHR$(73); CHR$(10);  
LPRINT "{BNo.{C"; CHR$(12); CHR$(34); CHR$(56);  
LPRINT CHR$(&HA);  
END
```

- If the printer finds a string of bar code data that does not begin with a code set select character, it immediately aborts the command processing and handles the subsequent data as normal data.
- If the printer received a character that is not available in the currently selected code set, it immediately aborts the command processing and handles the subsequent data as normal data.
- An HRI character corresponding to either a Shift character or a code select character is not printed. An HRI character for either a function character or a control character is treated as a space character.

**GS1 DataBar Omnidirectional**

This bar code, consisting of numerals only, has a fixed length of 13 columns.  
 The minimum height of the bar is 33 times of module size.  
 (The module size means the minimum width of bar/space that makes up GS1 DataBar. The value is set by GS w n command.)  
 No check digit is used.

**GS1 DataBar Truncated**

The difference from GS1 DataBar Omnidirectional is minimum size of bar height only. The minimum height of the bar is 13 times of module size.  
 The bar is suitable to print bar in slender space.  
 No check digit is used.

**GS1 DataBar Limited**

This code is the smallest symbology among GS1 DataBar symbologies and the size is minimized by the package indicator (top digits) limited to be "0" or "1". Therefore, the first byte of the data is fixed to "0"(48) or "1"(49).  
 The minimum height of the bar is 10 times of module size.  
 No check digit is used.

**GS1 DataBar Expanded**

This code covers ISO646(Upper/lower character aphanumeric, space, 20 symbols) and FNC1. Up to 77 digits numerals or up to 41 digits alphabet can be encoded to the bar code.

But following characters are treated as special character to enter special code to the barcode.

- "{" Escape character
- "(", ")" Application identifier
- "\*" Automatic check digit embedding

The minimum height of the bar is 34 times of module size.

Escape sequence	Function
{ {	Character "{" is encoded to barcode symbol.
{ (	Character "(" is encoded to barcode symbol.
{ )	Character ")" is encoded to barcode symbol.
{ *	Character "*" is encoded to barcode symbol.
{ 1	FNC1 is encoded to barcode symbol.

20 symbols

[ ! " % & ' ( ) \* + , - . / : ; < = > ? \_ ]

# GS w n

Support model	CT-S280	CT-S300	CT-S2000	CT-S4000	BD2-2220	PMU series
	CT-S281	CT-S310	CT-S801/851	CT-S601/601	CT-P29x series	CT-S310 II

**[Function]** Specifying the horizontal size (magnification) of bar code

**[Code]** <1D>H<77>H<n>

**[Range]**  $2 \leq n \leq 6$

**[Outline]** **[The specification which is common to the model]**  
 • Selecting bar code width.

**[Default]** n=3

**[Sample Program]**

```
LPRINT CHR$(&H1D);"h"; CHR$(30);
LPRINT CHR$(&H1D);"w"; CHR$(2);
GOSUB BC
LPRINT CHR$(&H1D);"h"; CHR$(50);
LPRINT CHR$(&H1D);"w"; CHR$(3);
GOSUB BC
LPRINT CHR$(&H1D);"h"; CHR$(80);
LPRINT CHR$(&H1D);"w"; CHR$(4);
GOSUB BC
END
BC:
LPRINT CHR$(&H1D);"k";
LPRINT CHR$(4);
LPRINT "12"; CHR$(0);
RETURN
```

**[Print Results]**

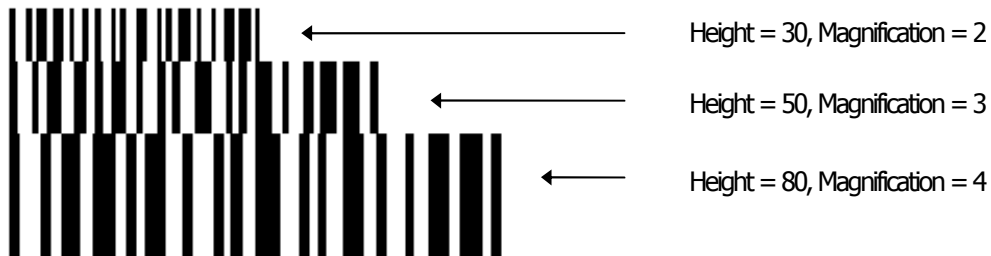

## 2.2.13 Commands for Non-volatile Memory

# GS ( C pL pH m fn b [c1 c2] [d1...dk]

Support model	CT-S280	CT-S300	CT-S2000	CT-S4000	BD2-2220	PMU series
	CT-S281	CT-S310	CT-S801/851	CT-S601/651	CT-P29x series	CT-S310 II

**[Function]** Editing user NV memory

**[Outline]** **[The specification which is common to the model]**

- Erases/stores/sends data of user NV memory area and sends the use amount/remaining capacity.
- Executes edit processing of user NV memory specified by function code (fn).

fn	Code	Function No.	Function
0, 48	GS ( C pL pH m fn b c1 c2	<a href="#">Function0</a>	Erases specified record.
1, 49	GS ( C pL pH m fn b c1 c2 d1...dk	<a href="#">Function1</a>	Stores data in specified record.
2, 50	GS ( C pL pH m fn b c1 c2	<a href="#">Function2</a>	Sends data stored in specified record.
3, 51	GS ( C pL pH m fn b	<a href="#">Function3</a>	Sends capacity of use (number of bytes).
4, 52	GS ( C pL pH m fn b	<a href="#">Function4</a>	Sends remaining capacity (number of bytes).
5, 53	GS ( C pL pH m fn b	<a href="#">Function5</a>	Sends key code list of stored record.
6, 54	GS ( C pL pH m fn b d1 d2 d3	<a href="#">Function6</a>	Erases all areas of user NV memory in a lump.

- pL, pH specifies the number of bytes of "m" and the following to (pL + pH x 256).
- c1, c2 specifies key code (ID code of record).
- Total capacity of user NV memory can be specified as any of [1K, 64K, 128K, 192K] bytes by GS ( E. Default value is 192K byte.

**[Caution]** **[The specification which is common to the model]**

- Frequent use of this command may result in damage of NV memory. Use the Write command to NV memory in consideration of [10 times max./day] .
- Following the processing of this command, printer Busy may occur during writing data in NV memory. While the printer is Busy, it stops receiving process. Therefore, data transmission (including real-time command) from host is prohibited.

**fn=0, 48: Function 0 Erasing Specified Record**

## **GS ( C pL pH m fn b kc1 kc2**

---

**[Code]** <1D>H<28>H<43>H<pL><pH><m><fn><b> [c1 c2]

**[Range]**  $(pL+pH \times 256) = 5 (pL=5, pH=0)$   
m=0  
fn=0, 48  
b=0  
 $32 \leq c1 \leq 126$   
 $32 \leq c2 \leq 126$

**[Outline]** **[The specification which is common to the model]**  
• Erases the record specified by c1, c2 stored in user NV memory.

**fn=1, 49: Function 1 Storing Data to Specified Record**

## **GS ( C pL pH m fn b c1 c2 d1...dk**

---

**[Code]** <1D>H<28>H<43>H<pL><pH><m><fn><b> [c1 c2] [d1...dk]

**[Range]**  $6 \leq (pL+pH \times 256) \leq 65535 (0 \leq pL \leq 255, 0 \leq pH \leq 255)$   
m=0  
fn=1, 49  
b=0  
 $32 \leq c1 \leq 126$   
 $32 \leq c2 \leq 126$   
 $32 \leq d \leq 254$   
 $k = (pL+pH \times 256) - 5$

**[Outline]** **[The specification which is common to the model]**  
• Stores data to the record specified by c1, c2.  
• When the data is present in NV memory, it is replaced by new data.



**fn=2, 50: Function 2 Sending Data Stored in Specified Record**

**GS ( C pL pH m fn b c1 c2**

**[Code]** <1D>H<28>H<43>H<pL><pH><m><fn><b> [c1 c2]

**[Range]** (pL+pH×256)=5 (pL=5, pH=0)  
 m=0  
 fn=2, 50  
 b=0  
 32≤c1≤126, 32≤c2≤126

**[Outline] [The specification which is common to the model]**

- Sends data stored in the record specified by c1, c2 in user NV memory.

	Hex.	Decimal	Data Size
Header	37H	55	1byte
Identifier	70H	112	1byte
Status	40H or 41H	64 or 65	0 to 80bytes
Data	20H to FEH	32 to 254	1byte
NUL	00H	0	1byte

- Transmission data in case specified record cannot be detected is as shown below.

	Hex.	Decimal	Data Size
Header	37H	55	1byte
Identifier	70H	112	1byte
Status	40H	64	1byte
NUL	00H	0	1byte

- When 40 or more key codes exist, they are divided in units of 40 maximum and the rest to be sent.  
 Status with a group of consecutive transmit data groups is 41H.  
 Status without a group of consecutive transmit data is 40H.
- After sending [Header - NUL], a response is received from host and next processing corresponding to the response is executed.

In case of "Status (with continuous block): hexadecimal number = 41H / decimal number = 65"

Response		Content of Processing
ASCII	Decimal	
ACK	6	Sends next data group.
NAK	21	Resends previous data group.
CAN	24	Cancel processing.

In case of "Status (last block): hexadecimal number = 40H / decimal number = 64"

Response		Content of Processing
ASCII	Decimal	
ACK	6	Terminates processing.
NAK	21	Resends previous data group.
CAN	24	Cancel processing.

## fn=3, 51: Function 3 Sending Use Amount

# GS ( C pL pH m fn b

---

**[Code]** <1D>H<28>H<43>H<pL><pH><m><fn><b>

**[Range]**  $(pL+pH \times 256) = 3$  (pL=3, pH=0)  
m=0  
fn=3, 51  
b=0

**[Outline]** **[The specification which is common to the model]**  
• Sends the use amount of user NV memory (number of bytes of used area).

**[Caution]** **[The specification which is common to the model]**  
• This command uses 20 bytes for user NV management information beforehand and sends the use amount of user NV memory by 20 bytes more than actual size.

	Hex.	Decimal	Data Size
Header	37H	55	1byte
Identifier	28H	40	1byte
Capacity of use	30H to 39H	48 to 57	1 to 6 bytes
NUL	00H	0	1byte

## fn=4, 52: Function 4 Sending Remaining Capacity

# GS ( C pL pH m fn b

---

**[Code]** <1D>H<28>H<43>H<pL><pH><m><fn><b>

**[Range]**  $(pL+pH \times 256) = 3$  (pL=3, pH=0)  
m=0  
fn=4, 52  
b=0

**[Outline]** **[The specification which is common to the model]**  
• Sends the remaining capacity of user NV memory (number of bytes of unused area).

**[Caution]** **[The specification which is common to the model]**  
• This command uses 20 bytes for user NV management information beforehand and sends the remaining capacity user NV memory by 20 bytes less than actual size.

	Hex.	Decimal	Data Size
Header	37H	55	1byte
Identifier	29H	41	1byte
Capacity of use	30H to 39H	48 to 57	1 to 6bytes
NUL	00H	0	1byte

**fn=5, 53: Function 5 Sending Key Code List of Stored Record**

# GS ( C pL pH m fn b

**[Code]** <1D>H<28>H<43>H<pL><pH><m><fn><b>

**[Range]** (pL+pH×256)=3 (pL=3, pH=0)  
 m=0  
 fn=5, 53  
 b=0

**[Outline]** **[The specification which is common to the model]**

- Sends key code list of record existing in user NV memory.

	Hex.	Decimal	Data size
Header	37H	55	1byte
Identifier	71H	113	1byte
Status	40H or 41H	64or65	1byte
Data	20H to FEH	32 to 254	2 to 80 bytes
NUL	00H	0	1byte

- Data is a data group with a list of key codes.

Transmission data group when record is not detected is as shown below.

	Hex.	Decimal	Data Size
Header	37H	55	1byte
Identifier	71H	113	1byte
Status	40H	64	1byte
NUL	00H	0	1byte

- After sending [Header - NUL] , receives a response from the host and executes the next processing corresponding to the response.

In case of "Status (with continuous block): hexadecimal number = 41H / decimal number = 65"

Response		Content of Processing
ASCII	Decimal	
ACK	6	Sends next data group.
NAK	21	Resends previous data group.
CAN	24	Cancels processing.

In case of "Status (last block): hexadecimal number = 40H / decimal number = 64"

Response		Content of Processing
ASCII	Decimal	
ACK	6	Terminates processing.
NAK	21	Resends previous data group.
CAN	24	Cancels processing.

**fn=6, 54: Function 6 Erasing All User NV Memory Area in a Lump**

**GS ( C pL pH m fn b [d1 d2 d3]**

---

**[Code]** <1D>H<28>H<43>H<pL><pH><m><fn><b> [d1 d2 d3]

**[Range]** (pL+pH×256)=6(pL=6, pH=0)  
m=0  
fn=6, 54  
b=0  
d1=67('C')  
d2=76('L')  
d3=82('R')

**[Outline]** **[The specification which is common to the model]**  
Erases all areas of user NV memory in a lump.

# GS ( L pL pH m fn [parameter]

# GS 8 L p1 p2 p3 p4 m fn [parameter]

Support model	CT-S280	CT-S300	CT-S2000	CT-S4000	BD2-2220	PMU series
	CT-S281	CT-S310	CT-S801/851	CT-S601/651	CT-P29x series	CT-S310 II

**[Function]** Specifying graphics data

**[Code]** <1D>H<28>H<4C>H<pL><pH><m><fn>  
<1D>H<38>H<4C>H<p1><p2><p3><p4><m><fn>

- \* In the explanation of function, the code of GS ( L is used.
- GS ( L and GS 8 L ) are the same function.
  - When [parameter] exceeds 65533 bytes in each function, GS 8 L is used.

**[Outline]** **[The specification which is common to the model]**

- Executes the processing related to the graphics data specified by the function code (fn).

fn	Code	Function No.	Function
0, 48	GS ( L pL pH m fn	<a href="#">Function48</a>	Sends NV graphics memory capacity.
2, 50	GS ( L pL pH m fn	<a href="#">Function50</a>	Prints graphics data stored in print buffer.
3, 51	GS ( L pL pH m fn	<a href="#">Function51</a>	Sends the remaining amount of NV graphics memory.
64	GS ( L pL pH m fn d1 d2	<a href="#">Function64</a>	Sends key code list of defined NV graphics.
65	GS ( L pL pH m fn d1 d2 d3	<a href="#">Function65</a>	Erases all data of NV graphics in a lump.
66	GS ( L pL pH m fn kc1 kc2	<a href="#">Function66</a>	Erases the specified NV graphics data.
67	GS ( L pL pH m fn a kc1 kc2 b xL xH yL yH [c d1...dk] 1... [c d1...dk] b	<a href="#">Function67</a>	Defines raster graphics data to NV memory.
69	GS ( L pL pH m fn kc1 kc2 x y	<a href="#">Function69</a>	Prints the specified NV graphics.
112	GS ( L pL pH m fn a bx by c xL xH yL yH d1...dk	<a href="#">Function 112</a>	Stores raster graphics data to print buffer.

- pL, pH specifies the number of bytes or "m" and later to (pL+pH×256).

**[Caution]** **[The specification which is common to the model]**

- Frequent use of this command may result in damage of NV memory. Use the Write command to NV memory in consideration of [10 times max./day] .
- Following the processing of this command, printer Busy may occur during writing data in NV memory. While the printer is Busy, it stops receiving process. Therefore, data transmission (including real-time command) from host is prohibited.

## fn=0, 48: Function 48 Sending NV Graphics Memory Capacity

### GS ( L pL pH m fn

---

**[Code]** <1D>H<28>H<4C>H<pL><pH><m><fn>

**[Range]**  $(pL+pH \times 256) = 2$  (pL=2, pH=0)  
m=48  
fn=0, 48

**[Outline]** **[The specification which is common to the model]**  
• Sends all capacity of NV graphics area in the number of bytes.

	Hex.	Decimal	Data Size
Header	37H	55	1 byte
Identifier	30H	48	1 byte
Data	30H to 39H	48 to 57	1 to 6 bytes
NUL	00H	0	1 byte

- Converts all capacity to character code expressed in decimal notation and sends it from higher digit.
- Data size is variable.
- All definition area can be specified by GS ( E out of [0, 64K, 128K, 192K, 256K, 320K, and 384K] . Default value is 384k bytes

## fn=2, 50: Function 50 Printing Graphics Data Stored in Print Buffer

### GS ( L pL pH m fn

---

**[Code]** <1D>H<28>H<4C>H<pL><pH><m><fn>

**[Range]**  $(pL+pH \times 256) = 2$  (pL=2, pH=0)  
m=48  
fn=2, 50

**[Outline]** **[The specification which is common to the model]**  
• Prints the graphics data stored in the print buffer in the processing of Function 112.  
• Executes paper feeding corresponding to the number of dots in Y direction of graphics stored in the print buffer.

## fn=3, 51: Function 51 Sending the Remaining Amount of NV Graphics Memory

# GS ( L pL pH m fn

---

**[Code]** <1D>H<28>H<4C>H<pL><pH><m><fn>

**[Range]**  $(pL+pH \times 256) = 2$  (pL=2, pH=0)  
m=48  
fn=3, 51

**[Outline]** **[The specification which is common to the model]**

- Sends the remaining amount of NV graphics area (number of bytes of unused area).

	<b>Hex.</b>	<b>Decimal</b>	<b>Data Size</b>
Header	37H	55	1 byte
Identifier	31H	49	1 byte
Data	30H to 39H	48 to 57	1 to 6 bytes
NUL	00H	0	1 byte

- Converts the remaining amount to character code expressed in decimal notation and sends it from higher digit.
- Data size is variable.

fn=64: Function 64 Sending Key Code List of Defined NV Graphics

# GS ( L pL pH m fn d1 d2

**[Code]** <1D>H<28>H<4C>H<pL><pH><m><fn><d1><d2>

**[Range]** (pL+pH×256)=4 (pL=4, pH=0)  
 m=48  
 fn=64  
 d1=75("K")  
 d2=67("C")

**[Outline]** **[The specification which is common to the model]**

- Sends the key code list of defined NV graphics.

When key code list is present

	Hex.	Decimal	Data Size
Header	37H	55	1 byte
Identifier	72H	114	1 byte
Status	40H or 41H	64or65	1 byte
Data	30H to 39H	48 to 57	2 to 80 bytes
NUL	00H	0	1 byte

When key code is not present

	Hex.	Decimal	Data Size
Header	37H	55	1 byte
Identifier	72H	114	1 byte
Data	40H	64	1 byte
NUL	00H	0	1 byte

- When 40 or more key codes are present, they are sent by being divided in unit of 40max.  
 Status with continuous transmission data group is 41H.  
 Status without continuous transmission data group is 40H.
- After sending [Header - NUL] , receives a response from the host and executes the next processing corresponding to the response.
- In case of "Status (with continuous block): hexadecimal number = 41H / decimal number = 65"

Response		Content of Processing
ASCII	Decimal	
ACK	6	Sends next data group.
NAK	21	Resends previous data group.
CAN	24	Cancel processing.

- In case of "Status (last block): hexadecimal number = 40H / decimal number = 64"

Response		Content of Processing
ASCII	Decimal	
ACK	6	Terminates processing.
NAK	21	Resends previous data group.
CAN	24	Cancel processing.



**fn=65: Function 65 Erasing All Data of NV Graphics in a Lump**

## **GS ( L pL pH m fn d1 d2 d3**

---

**[Code]** <1D>H<28>H<4C>H<pL><pH><m><fn><d1><d2><d3>

**[Range]** (pL+pH×256)=5(pL=5, pH=0)  
m=48  
fn=65  
d1=67("C")  
d2=76("L")  
d3=82("R")

**[Outline]** **[The specification which is common to the model]**  
Erases all defined data of NV graphics in a lump.

**fn=66: Function 66 Erasing Specified NV Graphics Data**

## **GS ( L pL pH m fn kc1 kc2**

---

**[Code]** <1D>H<28>H<4C>H<pL><pH><m><fn><kc1><kc2>

**[Range]** (pL+pH×256)=4(pL=4, pH=0)  
m=48  
fn=66  
32≤kc1≤126  
32≤kc2≤126

**[Outline]** **[The specification which is common to the model]**  
Erases the NV graphics data defined by key code (kc1, kc2).

**fn=67: Function 67 Defining Raster Type Graphics Data to NV Memory**

**GS ( L pL pH m fn a kc1 kc2 b xL xH yL yH**

**[c d1...dk] 1... [c d1...dk] b**

**[Code]** <1D>H<28>H<4C>H<pL><pH><m><fn><a><kc1><kc2><b><xL><xH><yL><yH>  
[c d1...d2] 1... [c d1...dk] b

**[Range]** Parameter of GS ( L  
 $12 \leq (pL + pH \times 256) \leq 65535 (0 \leq pL \leq 255, 0 \leq pH \leq 255)$   
 Parameter of GS 8 L  
 $12 \leq (p1 + p2 \times 256 + p3 \times 65536 + p4 \times 16777216) \leq 4294967295$   
 $(0 \leq p1 \leq 255, 0 \leq p2 \leq 255, 0 \leq p3 \leq 255, 0 \leq p4 \leq 255)$   
 Common parameter of GS ( L, GS 8 L  
 m=48  
 fn=67  
 a=48  
 $32 \leq kc1 \leq 126, 32 \leq kc2 \leq 126$   
 b=1, 2  
 $1 \leq (xL + xH \times 256) \leq 8192$   
 $1 \leq (yL + yH \times 256) \leq 2304$   
 c=49(When monochrome color paper is specified), c=49, 50(When 2-color paper is specified)  
 $0 \leq d \leq 255$   
 $k = (\text{int}((xL + xH \times 256) + 7/8) \times (yL + yH \times 256))$

All defined areas can be specified by GS ( E from [0, 64K, 128K, 192K, 256K, 320K, 384K] bytes. Default value is 384K bytes.

**[Outline] [The specification which is common to the model]**

Defines raster type graphics data to NV memory.

- "b" specifies the number of data colors.
- xL, xH specifies the horizontal direction of defined data to (xL+xH×256).
- yL, yH specifies the vertical direction of defined data to (yL+yH×256).
- "c" specifies the color of defined data.

c	Color of Defined Data
49	1st color
50	2nd color

- 1st color denotes black (high energy) in the specified 2-color thermal paper.
- 2nd color denotes red (low energy) in the specified 2-color thermal paper.

**[Caution] [The specification which is common to the model]**

- When multiple colors is specified by "b" and the same color is selected by "c", the command processing is terminated at that point, validating the defined data processed so far and the remaining data is read and discarded.

**fn=69: Function 69 Printing Specified Graphics**

# **GS ( L pL pH m fn kc1 kc2 x y**

---

**[Code]** <1D>H<28>H<4C>H<pL><pH><m><fn><kc1><kc2><x><y>

**[Range]** (pL+pH×256)=6 (pL=6, pH=0)  
m=48  
fn=69  
32≤kc1≤126  
32≤kc2≤126  
x=1, 2  
y=1, 2

**[Outline]** **[The specification which is common to the model]**  
• Prints the NV graphics data defined by key code (kc1, kc2) as large as x times horizontally/y times vertically.

**fn=112: Function 112 Storing Raster Type Graphics Data to Print Buffer**

# GS ( L pL pH m fn a bx by c xL xH yL yH d1...dk

**[Code]** <1D>H<28>H<4C>H<pL><pH><m><fn><a><bx><by><c><xL><xH><yL><yH> [d1...dk]

**[Range]** Parameter of GS ( L  
 $11 \leq (pL+pH \times 256) \leq 65536 (0 \leq pL \leq 255, 0 \leq pH \leq 255)$   
 Parameter of GS 8 L  
 $11 \leq (p1+p2 \times 256) + p3 \times 65536 + p4 \times 16777216 \leq 4294967295$   
 $(0 \leq p1 \leq 255, 0 \leq p2 \leq 255, 0 \leq p3 \leq 255, 0 \leq p4 \leq 255)$   
 Common parameter of GS ( L, GS 8 L  
 m=48  
 fn=112  
 a=48  
 bx=1, 2  
 by=1, 2  
 c=49(When monochrome color paper is specified), c=49, 50 (When 2-color paper is specified)  
 $1 \leq (xL+xH \times 256) \leq 1024$   
  
 When monochrome color paper is specified  
 $1 \leq (yL+yH \times 256) \leq 1662$ (with by=1)  
 $1 \leq (yL+yH \times 256) \leq 831$ (with by=2)  
  
 When 2-color paper is specified  
 $1 \leq (yL+yH \times 256) \leq 831$ (with by=1)  
 $1 \leq (yL+yH \times 256) \leq 415$ (with by=2)  
  
 $0 \leq d \leq 255$   
 $k = (\text{int}((xL+xH \times 256) + 7/8)) \times (yL+yH \times 256)$

- [Outline]** **[The specification which is common to the model]**
- Stores raster type graphics data to print buffer as large as x times horizontally/y times vertically.
  - xL, xH specifies the horizontal direction of raster graphics data to (xL + xH x 256).
  - yL, yH specifies the vertical direction of raster graphics data to (yL + yH x 256).
  - "c" specifies the color of print data.

c	Color of Print Data
49	1st color
50	2nd color

- 1st color denotes black (high energy) in the specified 2-color thermal paper.
- 2nd color denotes red (low energy) in the specified 2-color thermal paper.

- [Caution]** **[The specification which is common to the model]**
- In STANDARD MODE, each color can be defined only once.

# GS g 0 m nL nH

Support model	CT-S280	CT-S300	CT-S2000	CT-S4000	BD2-2220	PMU series
	CT-S281	CT-S310	CT-S801/851	CT-S601/651	CT-P29x series	CT-S310 II

**[Function]** Initializing maintenance counter

**[Code]** <1D>H<67>H<30>H<m><nL><nH>

**[Range]** m=0  
 $20 \leq (nL + nH \times 256) \leq 70$  (nL=20, 21, 50, 70, nH=0)

**[Outline]** **[The specification which is common to the model]**

- Set the value of resettable maintenance counter specified to 0.
- nL, nH are used to set the maintenance counter number to (nL+nH×256).

Counter Number		Counter [Unit]
Hex.	Decimal	
14H	20	Paper-feed line [line]
15H	21	Head powering count [times]
32H	50	Auto-cutter drive count [times]
46H	70	Product operation time [hours]

**[Caution]** **[The specification which is common to the model]**

- This command, if used frequently, may destroy NV memory, thus write command to NV memory shall be used less than [10 times/day] as a guideline.
- Along with processing this command, during data-writing to NV memory, printer BUSY may occur. During the printer BUSY, to stop receive processing, this printer prohibits the data sending (including real-time command) from host.

# GS g 2 m nL nH

Support model	CT-S280	CT-S300	CT-S2000	CT-S4000	BD2-2220	PMU series
	CT-S281	CT-S310	CT-S801/851	CT-S601/651	CT-P29x series	CT-S310 II

**[Function]** Sending maintenance counter

**[Code]** <1D>H<67>H<32>H<m><nL><nH>

**[Range]** m=0  
 $20 \leq (nL + nH \times 256) \leq 198$   
nL=20, 21, 50, 70, 148, 149, 178, 198  
nH=0

**[Outline]** **[The specification which is common to the model]**

- Send the maintenance counter value specified.
- nL, nH are used to set the maintenance counter number to (nL+nH×256).

Counter Number		Counter [Unit]	Counter Type
Hex.	Decimal		
14H	20	Paper-feed line [line]	Resettable
15H	21	Head powering count [times]	Resettable
32H	50	Auto-cutter drive count [times]	Resettable
46H	70	Product operation time [hours]	Resettable
94H	148	Paper-feed line [line]	Accumulated
95H	149	Head powering count [times]	Accumulated
B2H	178	Auto-cutter drive count [times]	Accumulated
C6H	198	Product operation time [hours]	Accumulated

- Configuration of data to be sent is shown below for the maintenance counter.

	Hex.	Decimal	Data Count
Header	5FH	95	1 byte
Data	30H to 39H	48 to 57	1 to 10 bytes
NUL	00H	0	1 byte

**[Caution]** **[The specification which is common to the model]**

- During sending block data (maintenance counter value), real-time status and ASB status shall not be sent. Thus, during sending the data, printer status can not be notified.
- Counter value sent by this command is only a guideline value. Due to an error occurrence and power off timing, figure data may have an error.
- To update the flash memory, write the flash memory if any change occurs in the maintenance counter when the period where the printer is not in operation (printing, paper feeding, drawer, or cutting) lasts about 10 seconds, 2 minutes, and 1 hour.
- If change occurs in each counter, data on RAM is updated correspondingly.

# FS p n m

Support model	CT-S280	CT-S300	CT-S2000	CT-S4000	BD2-2220	PMU series
	CT-S281	CT-S310	CT-S801/851	CT-S601/651	CT-P29x series	CT-S310 II

**[Function]** Printing the download NV bit images

**[Code]** <1C>H<70>H<n><m>

**[Range]** 1≤n≤255, 0≤m≤3, 48≤m≤51

**[Outline]** **[The specification which is common to the model]**

- This command prints the download NV bit images (n) using a specified mode (m).

m	Mode Name	Dot Density in Vertical Direction	Dot Density in Horizontal Direction
0, 48	NORMAL MODE	203dpi	203dpi
1, 49	DOUBLE WIDTH MODE	203dpi	101dpi
2, 50	DOUBLE HEIGHT MODE	101dpi	203dpi
3, 51	QUADRUPLE SIZE MODE	101dpi	101dpi

- "n" denotes the number of the download bit image.
- "m" denotes the bit image mode.

**[Caution]** **[The specification which is common to the model]**

- When the specified NV bit image "n" is undefined, this command is invalid.
- When the STANDARD MODE is selected, this command is valid only when there is no data in the print buffer.
- This command is invalid when PAGE MODE is selected.
- Any printing modes except the upside-down printing mode (i.e. emphasis, double strike, underlining, character size, inverted character printing, 90°-right-turned) are not affected.
- When the printing area set by the functions GS L and GS W is not enough for one vertical line of the download NV bit image, the line alone is dealt with as follows.  
One vertical line of the bit image is 1 dot in NORMAL MODE (m = 0, 48) and DOUBLE HEIGHT MODE (m = 2, 50), and it is 2 dots in double WIDTH MODE (m = 1, 49) and QUADRUPLE SIZE MODE (m = 3, 51).  
(1) The printing area is extended to the right side within the limits of the printing area so that one vertical line of the download NV bit image can be printed.  
(2) When a sufficient printing area cannot be maintained even after executing (1), the printing area is extended to the left side. (The left margin is reduced.)
- When the size of a bit image exceeds the limits of the printing area, the data within the limits of the printing area will be printed but the parts exceeding the limit will not be printed.
- Regardless of the amount of line feed set with ESC 2 and ESC 3, NORMAL MODE and DOUBLE WIDTH MODE execute a paper feed of (height "n" of NV bit image) dots while DOUBLE HEIGHT MODE and QUADRUPLE SIZE MODE execute a paper feed of (height "n" of NV bit image x2) dots.
- At the completion of the bit image printing, the head of the line will be used for the next printing position and normal data processing will take place.

**[See Also]** [ESC\\*](#), [FSq](#), [GS/](#), [GSv0](#)

# FS q n [xL xH yL yH d1...dk] 1... [xL xH yL yH d1...dk] n

Support model	CT-S280	CT-S300	CT-S2000	CT-S4000	BD2-2220	PMU series
	CT-S281	CT-S310	CT-S801/851	CT-S601/651	CT-P29x series	CT-S310 II

**[Function]** Defining the download NV bit image

**[Code]** <1C>H<71>H<n> [<xL><xH><yL><yH><d1...dk>] 1... [<xL><xH><yL><yH><d1...dk>] n

**[Range]**  $1 \leq n \leq 255$ ,  $0 \leq xL \leq 255$   
 $0 \leq xH \leq 3$  but,  $1 \leq (xL + xH \times 256) \leq 1023$   
 $0 \leq yL \leq 255$   
 $0 \leq yH \leq 1$  but,  $1 \leq (yL + yH \times 256) \leq 288$   
 $0 \leq d \leq 255$   
 $k = (xL + xH \times 256) \times (yL + yH \times 256) \times 8$   
**CT-S280/CT-S281/CT-S300/CT-S310/BD2-2220/PMU Series**  
**CT-P29x series**  
 Total definition area=256K bytes  
**CT-S2000/CT-4000/CT-S801/CT-S851/CT-S601/CT-S651/CT-S301II**  
 Total definition area=384K bytes

- [Outline]** **[The specification which is common to the model]**
- This command defines the specified NV bit image.
  - "n" denotes the number of bit images to be defined.
  - xL and xH denote the horizontal size of one NV bit image as  $(xL + xH \times 256) \times 8$  dots.
  - yL and yH denote the vertical size of one NV bit image as  $(yL + yH \times 256) \times 8$  dots

- [Caution]** **[The specification which is common to the model]**
- Because all the NV bit images previously defined by this command are deleted, it is not possible to redefine any one of the previously defined multiple data. All the data must be resent.
  - Any mechanical operation such as opening the cover, initializing the printer head position, or using the paper-feed switch etc can't execute from the execution of this command until the completion of the hardware reset,
  - When the STANDARD MODE is selected, this command is only valid when it is written at the head of a line.
  - This command is invalid when PAGE MODE is selected.
  - This command becomes valid after the 7 bytes of <FS q n xL xH yL yH> are processed as normal values.
  - When data which exceeds the remaining capacity of the defined area is specified by xL, xH, yL, yH, outside-defined-area arguments will be processed.
  - When outside-defined-area arguments are processed for the first bit image data group, this command becomes invalid.
  - If outside-defined-area arguments are processed for the second or subsequent NV bit image data groups, the processing of this command is suspended, and a writing process into the non-volatile memory starts. At this time, the NV bit image being defined becomes invalid (Undefined), but the preceding NV bit images are valid.
  - "d" denotes the definition data. Bits which correspond to dots to be printed are represented as "1", and those not to be printed as "0".
  - The definition will start from NV bit image number 01H and n-number bit images will be defined in ascending order. Therefore, the first data group [xL xH yL yH d1... dk] becomes NV bit image number 01H, and the last data group [xL xH yL yH d1... dk] becomes NV bit image number 0nH. These numbers of NV bit images coincide with those specified with FS p.



- The definition data of one NV bit image consists of [xL xH yL yH d1... dk] . Therefore, when only one NV bit image is defined, n = 1; the data group [xL xH yL yH d1... dk] is manipulated once, and ( [Data: (xL + xH x256) x( yL + yH x256 ) x8 ] + [Header: 4] ) bytes of non-volatile memory is used to store it
- The maximum definition area of printer depends on model. Multiple NV bit images can be defined, but bit images of which total size (Bit image data + Header) exceeds capacity of definition area can not be defined.
- The printer state will change to BUSY just before the writing operation into the non-volatile memory begins. Also, the printer state will change to BUSY just before the writing operation begins regardless of the state of the MSW even at a printer that have a MSW 1-3 [Busy condition]
- While this command is being executed, it is not possible to send ASB status or to detect the printer status even when the ASB function is selected.
- If this command is sent while a macro is still being defined, the definition process will be stopped and the execution of this command will start.
- NV bit images that are defined already are not initialized by using ESC @ command, or by resetting the printer or turning the power off.
- The command only executes definition of NV bit image, but not start printing. The printing of NV bit image will be executed by FS p.
- Because frequent writing in the non-volatile memory can destroy the memory, the writing command should be used less than 10 times a day.
- It may happen that the printer becomes BUSY during the process of writing data into the non-volatile memory in the execution of this command. When the printer becomes BUSY, it will stop receiving data. Therefore, sending data from the host (including real time command) is prohibited.

**[See Also]**

[FS p, GS \\*](#)

## 2.2.14 Kanji Control Commands

# FS!n

Support model	CT-S280	CT-S300	CT-S2000	CT-S4000	BD2-2220	PMU series
	CT-S281	CT-S310	CT-S801/851	CT-S601/651	CT-P29x series	CT-S310 II

**[Function]** Collectively setting Kanji print mode

**[Code]** <1C>H<21>H<n>

**[Range]** 0≤n≤255

**[Outline]** **[The specification which is common to the model]**

- Collectively sets Kanji print mode.
- Each bit of "n" has the following meaning:

Bit	Function	Value	
		0	1
0	Undefined	-	-
1	Undefined	-	-
2	Double-width enlargement	Canceled	Specified
3	Double-height enlargement	Canceled	Specified
4	Undefined	-	-
5	Undefined	-	-
6	Undefined	-	-
7	Underline	Canceled	Specified

**[Caution]** **[The specification which is common to the model]**

- Setting both double-height and double-width enlargement causes four times enlargement.
- Underline is applied to all width of printed characters but not to the part skipped by HT. Underline is not applied to the character rotated by 90° clockwise.
- Thickness of underline is the value set by FS – (defaulted to 1 dot width).

**[Default]** n=0

**[See Also]** [FS-](#), [FSW](#), [GS!](#)

# FS &

Support model	CT-S280	CT-S300	CT-S2000	CT-S4000	BD2-2220	PMU series
	CT-S281	CT-S310	CT-S801/851	CT-S601/651	CT-P29x series	CT-S310 II

**[Function]** Setting Kanji mode

**[Code]** <1C>H<26>H

**[Outline]** **[The specification which is common to the model]**

- Sets Kanji mode.

Japanese Kanji specifications:

This command is invalid when Kanji code system is Shift JIS.

Kanji codes are processed in the order of the first byte and second byte.

This code is defaulted to the state of canceling Kanji mode.

**[The specification which depend on the model]**

**CT-S280/CT-S300/CT-S310/CT-S2000/CT-S4000/CT-S801/CT-S851**

**CT-S601/CT-S651/CT-S310 II**

Multilingual specifications (Hangul, Chinese):

Kanji codes are processed in the order of the first byte and second byte.

This code is defaulted to the state of setting Kanji mode.

**[See also]** [FS.](#), [FSC](#)

**[Sample Program]**

```
LPRINT CHR$(&H1C);"&";
LPRINT CHR$(&H34); CHR$(&H41);
LPRINT CHR$(&H3B); CHR$(&H7A);
LPRINT CHR$(&HA);
LPRINT CHR$(&H1C);".";
LPRINT CHR$(&H34); CHR$(&H41);
LPRINT CHR$(&H3B); CHR$(&H7A);
LPRINT CHR$(&HA);
```

**[Print Results]**

漢字 ← When setting Kanji mode  
4A;z ← When canceling Kanji mode

# FS - n

Support model	CT-S280	CT-S300	CT-S2000	CT-S4000	BD2-2220	PMU series
	CT-S281	CT-S310	CT-S801/851	CT-S601/651	CT-P29x series	CT-S310 II

**[Function]** Setting/canceling Kanji underline

**[Code]** <1C>H<2D>H<n>

**[Range]** 0≤n≤2, 48≤n≤50

**[Outline]** **[The specification which is common to the model]**

- Sets or cancels Kanji underline.

n	Function
0, 48	Cancels Kanji underline
1, 49	Sets 1-dot width Kanji underline
2, 50	Sets 2-dot width Kanji underline

**[Caution]** **[The specification which is common to the model]**

- Underline is applied to all width of printed characters but not applied to the part skipped by HT.
- Underline is not applied to the character rotated 90° clockwise.

**[See Also]** [FS !](#)

**[Sample Program]**

```
LPRINT CHR$(&H1C);"&";
LPRINT CHR$(&H1C);"-"; CHR$(0);
LPRINT CHR$(&H34); CHR$(&H41);
LPRINT CHR$(&H3B); CHR$(&H7A);
LPRINT CHR$(&H1C);"-"; CHR$(1);
LPRINT CHR$(&H34); CHR$(&H41);
LPRINT CHR$(&H3B); CHR$(&H7A);
LPRINT CHR$(&HA);
LPRINT CHR$(&H1C);"-";
```

**[Print Results]**

Canceling Kanji underline

←→

漢字漢字

←→

Setting Kanji underline

# FS .

Support model	CT-S280	CT-S300	CT-S2000	CT-S4000	BD2-2220	PMU series
	CT-S281	CT-S310	CT-S801/851	CT-S601/651	CT-P29x series	CT-S310 II

**[Function]** Canceling Kanji mode

**[Code]** <1C>H<2E>H

**[Outline]** **[The specification which is common to the model]**

- Cancels Kanji mode.

Japanese Kanji specifications:

This command is invalid when Kanji code system is Shift JIS.

This code is defaulted to the state of canceling Kanji mode.

**[The specification which depend on the model]**

**CT-S280/CT-S300/CT-S310/CT-S2000/CT-S4000/CT-S801/CT-S851**

**CT-S601/CT-S651/CT-S310II**

Multilingual specifications (Hangul, Chinese):

Kanji codes are processed in the order of the first byte and second byte.

This code is defaulted to the state of setting Kanji mode.

**[See Also]** [FS&](#), [FSC](#)

**[Sample Program]**

[Refer to the Sample Program and Printing Results for FS &.](#)

# FS 2 a1 a2 [d] k

Support model	CT-S280	CT-S300	CT-S2000	CT-S4000	BD2-2220	PMU series
	CT-S281	CT-S310	CT-S801/851	CT-S601/651	CT-P29x series	CT-S310 II

**[Function]** Defining external character

**[Code]** <1C>H<32>H<a1>H<a2>H [<d>] k

**[Range]** Japanese Kanji specifications:

- In case of JIS code system  
a1=<77>H, <21>H≤a2≤<7E>H
- In case of Shift JIS code system  
a1=<EC>H, <40>H≤a2≤<7E>H, <80>H≤a2≤<9E>H

Multilingual specifications (Hangul, Chinese):  
a1=<FE>H, <A1>H≤a2≤<FE>H

Common  
0≤d≤255  
k=72(FONTA: 24×24)  
k=32(FONTC: 16×16)  
**CT-S2000/CT-S4000**  
k=60(FONTB: 20×24)

**[Outline]** **[The specification which is common to the model]**

- Defines external Kanji character.
- a1, a2 show Kanji code to define external character and definition of 94 characters are available.
- "d" is data to be defined and the number of data to be defined is 72 bytes of vertical 3 bytes × 24 dots.
- Each data is created by "1" for printed dot and "0" for unprinted dot.

**[The specification which depend on the model]**  
**CT-S280/CT-S300/CT-S310/CT-S2000/CT-S4000/CT-S801/CT-S851**  
**CT-S601/CT-S651/CT-S310 II**

- In multilingual specifications (Chinese, Hangul), font B, font C cannot define.

**[Default]** All are space.

**[Sample Program]**

```
LPRINT CHR$(&H1C);"&";          DATA &H00, &H00, &H00, &H00, &H00, &H00
GOSUB SETCHR                    DATA &H00, &H00, &H60, &H00, &H00, &HF0
LPRINT CHR$(&H77); CHR$(&H21);   DATA &H00, &H01, &HF8, &H00, &H03, &HFC
LPRINT CHR$(&HA);                DATA &H00, &H07, &HFE, &H00, &H0F, &HFF
LPRINT CHR$(&H1C);".";          DATA &H00, &H00, &HF0, &H00, &H00, &HF0
END                               DATA &H00, &H00, &HF0, &H00, &H00, &HF0
                                DATA &H00, &H00, &HF0, &H00, &H00, &HF0
                                DATA &H00, &H00, &HF0, &H00, &H00, &HF0
                                DATA &H00, &H01, &HF0, &H1F, &HFF, &HF0
                                DATA &H1F, &HFF, &HF0, &H1F, &HFF, &HE0
                                DATA &H1F, &HFF, &HCO, &H00, &H00, &H00
                                DATA &H00, &H00, &H00, &H00, &H00, &H00

SETCHR:
LPRINT CHR$(&H1C);"2";          DATA &H00, &H01, &HF0, &H1F, &HFF, &HF0
LPRINT CHR$(&H77); CHR$(&H21);   DATA &H1F, &HFF, &HF0, &H1F, &HFF, &HE0
FOR I=1 TO 72                    DATA &H1F, &HFF, &HCO, &H00, &H00, &H00
  READ D                          DATA &H00, &H00, &H00, &H00, &H00, &H00
  LPRINT CHR$(D);
NEXT I
RETURN
```

**[Print Results]**

└ Registered character  
←

# FS C n

Support model	CT-S280	CT-S300	CT-S2000	CT-S4000	BD2-2220	PMU series
	CT-S281	CT-S310	CT-S801/851	CT-S601/651	CT-P29x series	CT-S310 II

**[Function]** Selecting Kanji code system

**[Code]** <1C>H<43>H<n>

**[Range]** 0≤n≤1, 48≤n≤49

**[Outline]** **[The specification which is common to the model]**

- Selects Kanji code system.

Japanese Kanji specifications:

n	Function
0, 48	Selects JIS code system.
1, 49	Selects Shift JIS code system.

**[The specification which depend on the model]**

**CT-S310 II**

Japanese Kanji specifications:

n	Function
0, 48	Selects JIS code system.
1, 49	Selects Shift JIS CP932 code system.
2, 50	Selects Shift JIS X0213 code system.

**[The specification which depend on the model]**

**CT-S280/CT-S300/CT-S310/CT-S2000/CT-S4000/CT-S801/CT-S851  
CT-S601/CT-S651/CT-S310 II**

Multilingual specifications (Hangul):

n	Function
0, 48	Selects KS code system.
1, 49	Selects Extend KS code system.

Multilingual specifications (Chinese):

This command is invalid

**[Caution]** **[The specification which is common to the model]**

- Kanji code valid in JIS code system is 21H to 7EH for both 1st and 2nd bytes.
- Kanji code valid in Shift JIS code system is as follows:
  - 1st byte is 81H to 9FH and E0H to EFH.
  - 2nd byte is 40H to 7EH and 80H to FCH.

**[The specification which depend on the model]**

**CT-S280/CT-S300/CT-S310/CT-S2000/CT-S4000/CT-S801/CT-S851/CT-S310 II  
CT-S601/CT-S651**

- Codes valid for KS code system are as follows:
  - Special symbol: 2121H to 2C71H
  - Hangeul: 3021H to 487EH
  - Area other than the above is SPACE.



- With Extend KS code  
 Special symbol: A1A1H to ACF1H  
 Hangeul: B0A1H to C8FEH  
 Area other than the above is SPACE.

**[Default]**      n=0

**[Sample Program]**

```
LPRINT CHR$(&H1C);"&";
LPRINT CHR$(&H1C);"C"; CHR$(0);
LPRINT CHR$(&H34); CHR$(&H41);
LPRINT CHR$(&H3B); CHR$(&H7A);
LPRINT CHR$(&HA);
LPRINT CHR$(&H1C);"C"; CHR$(1);
LPRINT CHR$(&H8A); CHR$(&HBF);
LPRINT CHR$(&H8E); CHR$(&H9A);
LPRINT CHR$(&HA);
LPRINT CHR$(&H1C);".";
```

**[Print Results]**

```
漢字 ← JIS code system printing
漢字 ← Shift JIS code system printing
```

# FS S n1 n2

Support model	CT-S280	CT-S300	CT-S2000	CT-S4000	BD2-2220	PMU series
	CT-S281	CT-S310	CT-S801/851	CT-S601/651	CT-P29x series	CT-S310 II

**[Function]** Setting Kanji space amount

**[Code]** <1C>H<53>H<n1><n2>

**[Range]** 0≤n1≤255  
0≤n2≤255

**[Outline]** **[The specification which is common to the model]**

- Sets both right and left space amount of Kanji in units of dot.
- Sets left space amount by [n1×(Basic calculation pitch)].
- Sets right space amount by [n2×(Basic calculation pitch)].

**[Caution]** **[The specification which is common to the model]**

- The right and left space amount in double-width mode are twice the setting.
- Setting independent line feed amount is possible in STANDARD MODE and PAGE MODE.
- Basic calculation pitch is set by GS P. Even if basic calculation pitch is changed by GS P after setting space amount, there is no change in the amount of line feed.  
When fractional number is caused by the calculation, it is corrected by the minimum pitch of mechanism and the rest is discarded.
- In STANDARD MODE, basic calculation pitch (x) in horizontal direction is used.
- In PAGE MODE, the following operation occurs depending on the start point.
  - (1) When the start point is set at "upper left" or "lower right" by ESC T, basic calculation pitch (y) of vertical direction (paper feed direction) is used.
  - (2) When the start point is set at "upper right" or "lower left" by ESC T, basic calculation pitch (x) of horizontal direction (at right angle to paper feed direction) is used.
- The maximum right spacing is capable of approximately 31.906 mm (255/203 inches). A setting greater than this maximum is trimmed to the maximum.

**[Default]** n1=0, n2=0

# FS W n

Support model	CT-S280	CT-S300	CT-S2000	CT-S4000	BD2-2220	PMU series
	CT-S281	CT-S310	CT-S801/851	CT-S601/651	CT-P29x series	CT-S310 II

**[Function]** Setting/canceling four times enlargement of Kanji

**[Code]** <1C>H<57>H<n>

**[Range]** 0≤n≤255

**[Outline]** **[The specification which is common to the model]**

- Sets or cancels four times enlargement of Kanji.
- "n" is valid only for the lowest bit (n0).
- Control by the lowest bit (n0) is shown as follows:

n0	Function
0	Cancels 4 times enlargement
1	Sets 4 times enlargement

Setting or canceling 4 times enlargement means setting or canceling both double-height and double-width enlargements simultaneously.

**[See Also]** [FS !](#)

**[Sample Program]**

```
LPRINT CHR$(&H1C);"&";
LPRINT CHR$(&H1C);"W"; CHR$(0);
LPRINT CHR$(&H34); CHR$(&H41);
LPRINT CHR$(&H3B); CHR$(&H7A);
LPRINT CHR$(&H1C);"W"; CHR$(1);
LPRINT CHR$(&H34); CHR$(&H41);
LPRINT CHR$(&H3B); CHR$(&H7A);
LPRINT CHR$(&HA);
LPRINT CHR$(&H1C);".";
```

**[Print Results]**

Canceling 4 times enlargement  
↓  
漢字漢字  
↑  
Setting 4 times enlargement

# FS ( A pL pH fn [...])

Support model	CT-S280	CT-S300	CT-S2000	CT-S4000	BD2-2220	PMU series
	CT-S281	CT-S310	CT-S801/851	CT-S601/651	CT-P29x series	CT-S310 II

**[Function]** Setting font attribute of Kanji

**[Outline]** Setting Kanji font attribute means execution of processing for Kanji font attribute by the value of "fn" specified.

fn	Function
48	Sets Kanji font

**[Outline]** **[The specification which is common to the model]**  
This command is effective only for the Japanese Kanji specifications.

**fn=48: Function 48 Set Kanji fonts**

## FS ( A pL pH fn m)

**[Code]** <1C>H<28>H<41>H <pL>< pH>< fn>< m>

**[Range]** (pL+pH×256)=2 (pL=2, pH=0)  
fn=48  
0≤m≤2, 48≤m≤50

**[Default]** m=0

**[Outline]** **[The specification which is common to the model]**  
Prints the succeeding characters with energy set for "m".  
This command is effective only for the Japanese Kanji specifications.

**[The specification which depend on the model]**

CT-S280/CT-S281/CT-S300/CT-S310/CT-S801/CT-S851/CT-S601/CT-S651  
BD2-2220/PMU series/CT-P29x series/CT-S310II

m	Function
0, 48	Kanji font A(24×24)
1, 49	invalid
2, 50	Kanji font C(16×16)

CT-S2000/CT-S4000

m	Function
0, 48	Kanji font A(24×24)
1, 49	Kanji font B(20×24)
2, 50	Kanji font C(16×16)

## 2.2.15 Black Mark Control Commands

# GS FF

Support model	CT-S280	CT-S300	CT-S2000	CT-S4000	BD2-2220	PMU series
	CT-S281	CT-S310	CT-S801/851	CT-S601/651	CT-P29x series	CT-S310 II

**[Function]** Printing and ejecting Black mark paper/ label paper

**[Code]** <1D>H<0C>H

**[Outline]** **[The specification which is common to the model]**

- This command prints the data in the printer buffer and ejects Black mark paper/ label paper.

**[The specification which depend on the model]**

**CT-S2000/CT-S4000/CT-S801/CT-S851/CT-S601/CT-S651**

Data in the print buffer is printed and black mark/label ejection is done by following order.

- When auto cutter enabled is selected
  - (1)The printed black mark/label paper is fed to the auto cutter position and full cutting is carried out.
  - (2)Setting the first position of next BM paper/label paper is carried out.
- When auto cutter disabled is selected
  - (1)Feeds the printed black mark/label paper to the position to be cut by the manual cutter or to be peeled off.
  - (2)Keeps waiting till cutting is made and FEED SW is pressed while blinking LED.
  - (3)If FEED SW is pressed, setting the first position of BM paper/label paper is carried out.
    - The printer is in the BUSY state till the processing of (3) is executed. If, however, FEED SW is not pressed in 3 seconds, the same operation as that with FEED SW is executed.

### CT-S281

Data in the print buffer is printed and black mark/label ejection is done by following order.

- When auto cutter enabled is selected
  - (1)The printed black mark/label paper is fed to the auto cutter position and full cutting is carried out.
    - MSW5-6=ON: When printer receives the enxt data, top of form detection is done in the way of (2).
  - (2)Setting the first position of next BM paper/label paper is carried out.
- When auto cutter disabled is selected
  - (1)Feeds the printed black mark/label paper to manual cut position or manual peel off position.
    - MSW5-6=ON: When printer receives the enxt data, top of form detection is done in the way of (2).
  - (2)Keeps waiting till cutting is made and FEED SW is pressed while blinking LED
    - MSW3-7 = ON: Keep waiting for FEED SW being pressed.
    - MSW3-7 = OFF: If FEED SW is not pressed in 3 seconds (default), the same operation as that with FEED SW is executed.
    - The time to wait for manual cut can be changed by <GS ( E > command.
  - (3) When FEED SW is pressed, feed the paper to detect next black mark/top of label
    - Printer is in BUSY state until (3) transaction is done.
    - When MSW4-5=OFF (Black mark), printer feed the paper backward by about 5mm.
    - When MSW4-5=ON (Label paper) if the distance between black mark or label length is less than

30mm, next or second next black mark/label will be ejected and then feed paper until detecting the black mark or top of label.

MSW3-7 CBM-270 mode OFF = Invalid ON = Valid

MSW5-6 Auto Back Feed OFF = After Cut ON = Before Print (Effective after DE0X-0400)

**[Caution]** **[The specification which is common to the model]**

- Valid only if Black mark paper/ label paper is selected.

**[See Also]** [FF](#), [GS <](#)

## GS <

Support model	CT-S280	CT-S300	CT-S2000	CT-S4000	BD2-2220	PMU series
	CT-S281	CT-S310	CT-S801/851	CT-S601/651	CT-P29x series	CT-S310 II

**[Function]** Initializing the printer mechanism

**[Code]** <1D>H<3C>H

**[Outline]** **[The specification which is common to the model]**

- Performs initializing operation at Black mark/ label similar to the initialization at power on.

**[Caution]** **[The specification which is common to the model]**

- This command is valid only when B.M paper/ label is chosen.
- Parameters configured by commands are not reset.

# GS A m n

Support model	CT-S280	CT-S300	CT-S2000	CT-S4000	BD2-2220	PMU series
	CT-S281	CT-S310	CT-S801/851	CT-S601/651	CT-P29x series	CT-S310 II

**[Function]** Correcting the leader position of Black mark paper/ label paper

**[Code]** <1D>H<41>H<m><n>

**[Range]** 0≤m≤255  
0≤n≤255

**[Outline]** **[The specification which is common to the model]**

- This command sets the leader position of Black mark paper/ label paper in terms of correction value set for the default position.
- "m" denotes the correcting direction.
- "m" is valid only for the lowest bit (m0).
- Control by the lowest bit (m0) is shown as follows:

m0	Correcting Direction
0	Corrects the leader position in the forward direction
1	Corrects the leader position in the reverse direction

- "n" denotes the correction value in units of n/203 inch.

**[Caution]** **[The specification which is common to the model]**

- This command is valid only when Black mark paper/ label paper is chosen.
- This command is ignored except immediately after the execution of a Black mark/ label positioning command (FF, GS FF, GS A, GS <) or immediately after leader positioning performed on a paper feed action with the FEED switch, power on, or cover closure.
- The maximum reverse correction span is 0.5 mm. Correction settings exceeding this value are truncated into the maximum value. The leader position may be deviated due to paper flexure. For reverse correction, exercise care so the leader position does not step out of the Black mark/ label.
- For forward correction, set the correction span by taking into account the Black mark/ label length as the printable area changes before and after correction setting.
- In calculating a correction span, use the basic calculation pitch (y) for the vertical direction. The fractional part contained in the calculation result should be corrected in units of the mechanism's minimum pitch, with the remaining fractional part truncated.

# GS C 0 m n

Support model	CT-S280	CT-S300	CT-S2000	CT-S4000	BD2-2220	PMU series
	CT-S281	CT-S310	CT-S801/851	CT-S601/651	CT-P29x series	CT-S310 II

**[Function]** Setting the numbering print mode

**[Code]** <1D>H<43>H<30>H<m><n>

**[Range]** 0≤m≤5  
0≤n≤2

**[Outline]** **[The specification which is common to the model]**

- This command sets the numbering (serial number counter) print mode.
- "m" denotes the number of print columns.
  - m=0 Prints the columns indicated by numeral. In this case, "n" has no meaning.
  - m=1 to 5 Indicates the maximum number of columns to be printed. Prints the counter in "m" columns. "n" specifies a printing position within the printing columns.
- n=0 Prints the data right justified. The blank columns are spaced.
- n=1 Prints the data right justified. The blank columns are filled with "0".
- n=2 Prints the data left justified. The right blank will become invalid.

**[Caution]** **[The specification which is common to the model]**

- If either "m" or "n" has a value beyond their ranges, that setting will become invalid.

**[Default]** m=0, n=0

**[See Also]** [GSC 1](#), [GSC 2](#), [GSC](#), [GSc](#)

**[Sample Program]**

```

LPRINT CHR$(&H1D);"C0";          *CNT
LPRINT CHR$(0); CHR$(0);         FOR I=1 TO 5
GOSUB *CNT                       LPRINT CHR$(&H1D);"c";
LPRINT CHR$(&H1D);"C0";          NEXT I
LPRINT CHR$(1); CHR$(0);         LPRINT CHR$(&HA);
GOSUB *CNT                       RETURN
LPRINT CHR$(&H1D);"C0";
LPRINT CHR$(3);CHR$(0);
GOSUB *CNT
LPRINT CHR$(&H1D);"C0";
LPRINT CHR$(3); CHR$(1);
GOSUB *CNT
LPRINT CHR$(&H1D);"C0";
LPRINT CHR$(3); CHR$(2);
GOSUB *CNT
END

```

**[Print Results]**

```

12345 ←———— Counts from 1 to 5 at m = 0 and n = 0.
67890 ←———— Counts from 6 to 10 at m = 1 and n = 0.
 11 12 13 14 15 ←—— Counts from 11 to 15 at m = 3 and n = 0.
016017018019020 ←—— Counts from 16 to 20 at m = 3 and n = 1.
21 22 23 24 25 ←—— Counts from 21 to 25 at m = 3 and n = 2.

```



# GS C 1 n1 n2 n3 n4 n5 n6

Support model	CT-S280	CT-S300	CT-S2000	CT-S4000	BD2-2220	PMU series
	CT-S281	CT-S310	CT-S801/851	CT-S601/651	CT-P29x series	CT-S310 II

**[Function]** Setting the numbering counter mode (A)

**[Code]** <1D>H<43>H<31>H<n1><n2><n3><n4><n5><n6>

**[Range]**  $0 \leq n1, n2, n3, n4, n5, n6 \leq 255$

**[Outline]** **[The specification which is common to the model]**

- This command sets the numbering (serial number counter) mode.
  - $n1+n2 \times 256$  ( $n1$ =remainder,  $n2$ =quotient): First value for counter range
  - $n3+n4 \times 256$  ( $n3$ =remainder,  $n4$ =quotient): Last value for counter range
  - $n5$ : Counter step value
  - $n6$ : Identical counter print counter
  - $(n1+n2 \times 256) < (n3+n4 \times 256)$ : Count-up system
  - $(n1+n2 \times 256) > (n3+n4 \times 256)$ : Count-down system
  - $(n1+n2 \times 256) = (n3+n4 \times 256)$  or  $n5=0$  or  $n6=0$ : Counter stop

**[Default]** **[The specification which is common to the model]**

$n1+n2 \times 256=1$   
 $n3+n4 \times 256=65535$   
 $n5=1$   
 $n6=1$

**[See Also]** [GSC0](#), [GSC2](#), [GSC](#), [GSc](#)

**[Sample Program]**

```

LPRINT CHR$(&H1D);"C0";          *CNT
LPRINT CHR$(3); CHR$(0);         FOR I=1 TO 5
LPRINT CHR$(&H1D);"C1";          LPRINT CHR$(&H1D);"c";
LPRINT CHR$(50); CHR$(0);        NEXT I
LPRINT CHR$(0); CHR$(0);         LPRINT CHR$(&HA);
LPRINT CHR$(5); CHR$(2);        RETURN
GOSUB *CNT
LPRINT CHR$(&H1D);"C2"; CHR$(5); CHR$(0);
LPRINT CHR$(10);
GOSUB *CNT
END
  
```

**[Print Results]**

1 1 50 50 45 ← When printing the counter value by setting a count-down range = 0 to 50, step value = 5, and repeat count = 2.

5 5 0 0 50 ← When printing the counter value by setting a count-down range to 0 to 50, step value = 5, and starting value = 5.

# GS C 2 n1 n2

Support model	CT-S280	CT-S300	CT-S2000	CT-S4000	BD2-2220	PMU series
	CT-S281	CT-S310	CT-S801/851	CT-S601/651	CT-P29x series	CT-S310 II

**[Function]** Setting the numbering counter

**[Code]** <1D>H<43>H<32>H<n1><n2>

**[Range]**  $0 \leq n1 \leq 255$   
 $0 \leq n2 \leq 255$

**[Outline]** **[The specification which is common to the model]**

- This command sets the numbering (serial number counter) value.
- $n1+n2 \times 256$  ( $n1$ =remainder,  $n2$ =quotient) becomes a counter value.

**[Caution]** • If the counter value is beyond the range specified with the GS C1 or GS C; command, the counter value will be the first value in counter data range.

**[Default]** Not defined.

**[See Also]** [GSC0](#), [GSC1](#), [GSC;](#), [GSc](#)

**[Sample Program]**

**[Print Results]**

[See the Sample Program and Print Results for the GS C1 command.](#)

# GS C ; n1 ; n2 ; n3 ; n4 ; n5 ;

Support model	CT-S280	CT-S300	CT-S2000	CT-S4000	BD2-2220	PMU series
	CT-S281	CT-S310	CT-S801/851	CT-S601/651	CT-P29x series	CT-S310 II

- [Function]**      Setting the numbering counter mode (B)
- [Code]**            <1D>H<43>H<3B>H<n1><3B>H<n2><3B>H<n3><3B>H<n4><3B>H<n5><3B>H<n1>, <n2>, <n3>, <n4>, <n5> are character codes.
- [Range]**            0≤n1, n2, n5≤65535  
0≤n3, n4≤255
- [Outline]**            **[The specification which is common to the model]**
- This command sets the numbering (serial number counter) mode and a counter value.
    - n1: First value of ounter range
    - n2: Last vale of counter range
    - n3: Counter step value
    - n4: Identical counter print count
    - n5: Counter start value
    - n1<n2: Count-up system
    - n1>n2: Count-down system
    - n1=n2 or n3= 0 or n4=0 : Counter stop
- [Caution]**            **[The specification which is common to the model]**
- If the n5 counter start value is beyond the counter range specified with n1 and n2, it is assumed to be n1=n5.
  - If each value of n1 through n5 contains the character code other than "0" through "9", the printer will invalidate the data up to that parameter and handle the subsequent data as normal data.
- [Default]**            n1=1, n2=65535, n3=1, n4=1, n5=1
- [See Also]**            [GSC0](#), [GSC1](#), [GSC2](#), [GSc](#)

# GS c

Support model	CT-S280	CT-S300	CT-S2000	CT-S4000	BD2-2220	PMU series
	CT-S281	CT-S310	CT-S801/851	CT-S601/651	CT-P29x series	CT-S310 II

**[Function]** Print the counter

**[Code]** <1D>H<63>H

**[Outline]** **[The specification which is common to the model]**

- This command prints the serial number counter data.
- After setting the current counter value in the print buffer as the print data (character string), it increments or decrements the counter according to the set count mode.

**[Caution]** **[The specification which is common to the model]**

- The format used in setting the value to the print buffer depends on the GS C0 command.
- The count mode is set by the GS C1 or GS C; command. When execution of "GS c" command results in excess of the last value of counter range, the counter returns to the first value of the counter range.

**[See Also]** [GSC0](#), [GSC1](#), [GSC2](#), [GSC;](#)

**[Sample Program]**

**[Print Results]**

[See the Sample Program and Print Results for the GS C0 command.](#)

[See the Sample Program and Print Results for the GS C1 command.](#)

# GS I n1L n1H n2L n2H

Support model	CT-S280	CT-S300	CT-S2000	CT-S4000	BD2-2220	PMU series
	CT-S281	CT-S310	CT-S801/851	CT-S601/651	CT-P29x series	CT-S310 II

**[Function]** Setting the Black mark/ label length

**[Code]** <1D>H<6C>H<n1L><n1H><n2L><n2H>

**[Range]**  $0 \leq n1L \leq 255$  ( $24 \leq n1L + n1H \times 256 \leq 360$ )  
 $0 \leq n1H \leq 1$   
 $8 \leq n2L \leq 30$   
 $n2H = 0$

**[Outline]** **[The specification which is common to the model]**

- Define the specifications (length) of the Black mark/ label used.
- n1: Sets the Black mark pitch/ label length
- n2: Sets the Black mark length/ label gap length
- n1 and n2 are specified units of millimeters.
- Divide the maximum Black mark pitch/ label length by 256 with the quotient designated as n1L and the remainder as n2H. Accordingly, the Black mark pitch/ label length available for setting will be  $n1L + n2H \times 256$ .

**[Caution]** **[The specification which is common to the model]**

- This command is valid if MSW4-1 is set to OFF.
- If the specified length is outside of Black mark/ label specifications, the default length is set.
- 300 mm is the maximum Black mark pitch/ label length allowed to define and 25 mm is the minimum.
- 30 mm is the maximum allowable Black mark length/ label gap length to define and 4 mm is the minimum.

**[Default]** The length at the last auto length detection is the default.

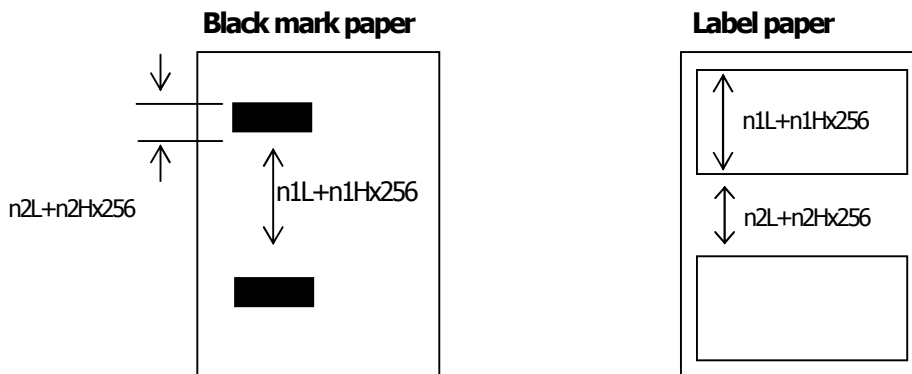

# GS p n

Support model	CT-S280	CT-S300	CT-S2000	CT-S4000	BD2-2220	PMU series
	CT-S281	CT-S310	CT-S801/851	CT-S601/651	CT-P29x series	CT-S310 II

**[Function]** Changing paper type

**[Code]** <1D>H <70>H <n>

**[Range]** 0≤n≤255  
 n=0 specify receipt paper  
 n=1 specify label paper  
 n=2 specify black mark paper

**[Outline]** **[The specification which is common to the model]**

- Switches paper.
- n = 0: Switches to receipt paper (mode).  
 Ignores this command when receipt mode is set.
- n = 1: Switches to label paper mode.  
 Measures paper length or sets first position of paper in accordance with the MSW setting.  
 Ignores this command when label paper mode is set.
- n = 2: Switches to BM paper mode.  
 Measures paper length or sets first position of paper in accordance with the MSW setting.  
 Ignores this command when BM paper mode is set.

**[Caution]** **[The specification which is common to the model]**

- Processed after buffering.
- This command is not initialized by the initialization command.
- This command is initialized by power OFF and paper type set by MSW is valid from the next power ON.
- When BM paper/Label paper mode is changed to receipt mode  
 Change the paper to receipt paper after sending this command (n=0) with BM paper/label paper set. If the paper is changed to receipt paper beforehand, sensing the first position is not available when closing the cover, resulting in BM/label detection error.
- When receipt mode is changed to label mode  
 Send this command (n=1) after changing the paper from receipt paper to label paper. If this command is sent beforehand, label detection error is caused.

# FS FF

Support model	CT-S280	CT-S300	CT-S2000	CT-S4000	BD2-2220	PMU series
	CT-S281	CT-S310	CT-S801/851	CT-S601/651	CT-P29x series	CT-S310 II

**[Function]** Printing and feeding black mark/label paper to manual cut position

**[Code]** <1C>H <0C>H

**[Outline]** **[The specification which is common to the model]**

1. Printer feeds the printed black mark/label paper to the position for manual cut or peeling off.
2. If FEED switch is pressed at manual cut position, printer feeds the paper back to top print position of black mark/label.
3. If printer receives print data at manual cut position, printer feeds the paper back to top print position of black mark/label, then prints the data.
4. This function works regardless of auto cutter setting to be enabled/disabled.

**[Caution]** **[The specification which is common to the model]**

- Valid only if Black mark paper/ label paper is selected.

**[See Also]** FF, GS <

## 2.2.16 Printer Function Setting Commands

# GS ( D pL pH m [a1 b1] ... [ak bk]

Support model	CT-S280	CT-S300	CT-S2000	CT-S4000	BD2-2220	PMU series
	CT-S281	CT-S310	CT-S801/851	CT-S601/651	CT-P29x series	CT-S310 II

**[Function]** Enabling or disabling real-time command

**[Code]** <1D>H<28>H<44>H<pL>< pH>< m> [<a1>< b1>] ... [<ak>< bk>]

**[Range]**  $3 \leq (pL + pH \times 256) \leq 65535$   
M=20  
a=1  
b=0, 1, 48, 49

**[Outline]** **[The specification which is common to the model]**  
• Enables/disables the following real-time command processing.

a	b	Function
1	0, 48	Does not process DLE DC4 fn m t (fn=1). (Invalid)
	1, 49	Processes DLE DC4 fn m t (fn=1). (Valid)

- pL and pH sets the number of bytes on and after m in (pL + pH×256).
- "a" sets the kind of real-time command.
- "b" sets Valid or Invalid.
- When data raw that meets the code configuring real-time command in the image data, it is recommended that the real-time command be set to invalid by this command.

**[Default]**

a	Type of Real-time Command	Initial Value
1	DLE DC4 fn m t (fn=1): Real-time output of pulse specified	Valid

**[Caution]** **[The specification which is common to the model]**

### PMU2XXXII/PMU2300III

- Among PMU series, only PMU2xxx type II and III support this function.



# GS ( E pL pH fn [...]

Support model	CT-S280	CT-S300	CT-S2000	CT-S4000	BD2-2220	PMU series
	CT-S281	CT-S310	CT-S801/851	CT-S601/651	CT-P29x series	CT-S310 II

**[Function]** Printer function setting command

**[Outline]** **[The specification which is common to the model]**

- Printer function setting command is a command to change the function of the printer stored on the non-volatile memory and executes the function set by the value of "fn".

Function No. (fn)	Function
<a href="#">Function 1</a>	Transfers to printer function setting mode.
<a href="#">Function 2</a>	Terminates printer function setting mode.
<a href="#">Function 3</a>	Sets memory switch value.
<a href="#">Function 4</a>	Sends memory switch value set.
<a href="#">Function 5</a>	Sets customize value.
<a href="#">Function 6</a>	Sends customized value set.
<a href="#">Function 7</a>	Copies user-defined page.
<a href="#">Function 8</a>	Defines the data in column format to the character code page of work area.
<a href="#">Function 9</a>	Defines the data in raster format to the character code page of work area.
<a href="#">Function 10</a>	Erases the data of character code page of work area.
<a href="#">Function 11</a>	Sets the communication condition of serial interface. (Note)
<a href="#">Function 12</a>	Sends the communication condition of serial interface set.
<a href="#">Function 255</a>	Sets all contents set in printer function setting mode to the state at the time of shipment.

- pL, pH set the number of bytes following "fn" to (pL + pH×256).
- At the end of printer function setting mode (Function 2), resetting is executed. Then the input buffer is cleared to return various kinds of setting to the state at the time of power on.
- The set value can be confirmed without transferring to printer function setting mode by functions 4, 6, and 12.
- Other functions do not operate without transferring to printer function setting mode.

**[Caution]** **[The specification which is common to the model]**

- This command allows writing to non-volatile memory. Therefore, using this command frequently may result in breakage of memory. Use this command appropriately [10 times max./day].
- During execution of this command, the printer is in Busy state and stops receiving operation. Therefore, data transmission from the host is prohibited.

## fn=1: Function 1 Transferring to Printer Function Setting Mode

# GS ( E pL pH fn d1 d2

---

**[Code]** <1D>H<28>H<45>H <pL><pH><fn><d1><d2>

**[Range]** (pL+pH×256)=3 (pL=3, pH=0)  
fn=1  
d1=73 ("I")  
d2=78 ("N")

**[Outline]** **[The specification which is common to the model]**  
• Transfers to printer function setting mode and sends the report of mode transfer.

	Hex.	No. of Data
Header	37H	1
ID	20H	1
NULL	00H	1

## fn=2: Function 2 End of Printer Function Setting Mode

# GS ( E pL pH fn d1 d2 d3

---

**[Code]** <1D>H<28>H<45>H <pL><pH><fn><d1><d2><d3>

**[Range]** (pL+pH×256)=4 (pL=4, pH=0)  
fn=2  
d1=79 ("O")  
d2=85 ("U")  
d3=84 ("T")

**[Outline]** **[The specification which is common to the model]**  
• Terminates printer function setting mode and executes resetting.  
• Clears input buffer and print buffer and restores various kinds of setting to the state at power on.  
• Operates only in printer function setting mode.

### fn=3: Function 3 Setting Memory Switch Value

## GS ( E pL pH fn [a1 b18...b11] ... [ak bk8...bk1]

**[Code]** <1D>H<28>H<45>H<pL><pH><fn> [<a1><b18>...<b11>] ... [<ak><bk8>...<bk1>]

**[Range]**  $10 \leq (pL + pH \times 256) \leq 65535$   
fn=3  
b=48, 49, 50  
**CT-S280/BD2-2220**  
a=1, 2, 3  
**CT-S300**  
a=1, 2, 3, 4  
**CT-S281/CT-S310/CT-S2000/CT-S4000/PMU2XXX/PMU2XXXII**  
**CT-P29x series**  
a = 1, 2, 3, 4, 5  
**CT-S801/CT-S851/CT-S601/CT-S651/CT-S310II**  
a=1, 2, 3, 4, 5, 6  
**PMU2300III**  
a=1, 2, 3, 4, 5, 11, 12

**[Outline]** **[The specification which is common to the model]**

- Changes the MSW set in a to the value set in "b".

B	Function
48	Sets corresponding bit to OFF.
49	Sets corresponding bit to ON.
50	Does not change corresponding bit.

**[Caution]** **[The specification which depend on the model]**

**CT-S281/CT-S310/CT-S2000/CT-S4000/CT-S801/CT-S851**  
**CT-S601/CT-S651/ PMU series**

- MSW7 to MSW10 cannot be changed by this command. They can be changed by the setting of customize value.

## CT-S280

### • Setting MSW 1 (a=1)

n	b (Set Value)	Function
1	48 (Default)	Reports the power on.
	49	Does not report power on.
2	48 (Default)	Sets input buffer capacity to 4K bytes.
	49	Sets input buffer capacity to 45 bytes.
3	48 (Default)	Sets input buffer full and offline to be Busy.
	49	Sets to be busy with input buffer full.
4	48 (Default)	At the occurrence of receiving error, replaces the data with "?".
	49	At the occurrence of receiving error, ignores the data.
5	48 (Default)	Disables CR (ODH).
	49	Enables CR (ODH).
6	48 (Default)	Reserved
7	48 (Default)	Does not reset at serial I/F pin 6.
	49	Resets at serial I/F pin 6.
8	48 (Default)	Reserved

### • Setting MSW 2 (a=2)

n	b (Set Value)	Function
1	49(Default)	Reserved
2	48(Default)	Reserved
3	48 (Default)	Enables stored printing.
	49	Disables stored printing.
4	48 (Default)	Immediately after digit reaches full, line-feed is taken.
	49	Immediately after digit reaches full, data wait is taken.
5	48 (Default)	After cover close and PE recovery, prints as it is.
	49	After cover close and PE recovery, prints from the beginning using PAGE MODE, barcode, image, double-height printing, etc. as a unit.
6	49 (Default)	Reserved
7	48 (Default)	Reserved
8	48 (Default)	Enables PNE.
	49	Disables PNE.

### • Setting MSW 3 (a=3)

n	b (Set Value)	Function
1	48 (Default)	Reserved
2	48 (Default)	Reserved
3	48 (Default)	Resets with parallel pin 31.
	49	Does not reset with parallel pin 31.
4	48 (Default)	Reserved
5	48 (Default)	Reserved
6	48 (Default)	Reserved
7	48	Sets CBM270-noncompatible mode.
	49 (Default)	Sets CBM270-compatible mode.
8	48 (Default)	Sets cover open error during printing to be auto recovery error.
	49	Sets cover open error during printing to be recoverable error.

## CT-S281

### • Setting MSW 1 (a=1)

n	b (Set Value)	Function
1	48 (Default)	Reports the power on.
	49	Does not report power on.
2	48 (Default)	Sets input buffer capacity to 4K bytes.
	49	Sets input buffer capacity to 45 bytes.
3	48 (Default)	Sets input buffer full and offline to be Busy.
	49	Sets to be busy with input buffer full.
4	48 (Default)	At the occurrence of receiving error, replaces the data with "?".
	49	At the occurrence of receiving error, ignores the data.
5	48 (Default)	Disables CR (ODH).
	49	Enables CR (ODH).
6	48 (Default)	Reserved
7	48 (Default)	Does not reset at serial I/F pin 6.
	49	Resets at serial I/F pin 6.
8	48 (Default)	Reserved

### • Setting MSW 2 (a=2)

n	b (Set Value)	Function
1	49(Default)	Reserve
2	48	Disables auto cutter.
	49 (Default)	Enables auto cutter.
3	48 (Default)	Enables stored printing.
	49	Disables stored printing.
4	48 (Default)	Immediately after digit reaches full, line-feed is taken.
	49	Immediately after digit reaches full, data wait is taken.
5	48 (Default)	After cover close and PE recovery, prints as it is.
	49	After cover close and PE recovery, prints from the beginning using PAGE MODE, barcode, image, double-height printing, etc. as a unit.
6	49 (Default)	Reserved
7	48 (Default)	Reserved
8	48	Enables PNE.
	49 (Default)	Disables PNE.

### • Setting MSW 3 (a=3)

n	b (Set Value)	Function
1	48 (Default)	After clearing cutter error, can be restored by Feed SW.
	49	After clearing cutter error, cannot be restored by Feed SW.
2	48 (Default)	Reserved
3	49 (Default)	Reserved
4	48 (Default)	Reserved
5	48 (Default)	Reserved
6	48 (Default)	Reserved
7	48	Sets EPSON compatible mode.
	49 (Default)	Sets CBM270-compatible mode.
8	48 (Default)	Sets cover open error during printing to be auto recovery error.
	49	Sets cover open error during printing to be recoverable error.

## CT-S281

### • Setting MSW 4 (a=4)

n	b (Set Value)	Function
1	48 (Default)	At the selection of Black mark/Label paper, enables auto end-measurement.
	49	At the selection of Black mark/Label paper, disables auto end-measurement.
2	48 (Default)	Finding top of form at power ON disabled.
	49	Finding top of form at power ON enabled.
3	48 (Default)	Feed & Cut at TOF disabled.
	49	Feed & Cut at TOF enabled.
4	48 (Default)	Uses thermal roll paper.
	49	Uses Black mark paper/ label paper.
5	48 (Default)	Detects paper position and black mark.
	49	Detects paper position and inter-label distance.
6	48 (Default)	Paper type selection disabled
	49	Paper type selection enabled
7	48 (Default)	Label mode 1 - Auto paper type selection disabled
	49	Label mode 2 – Auto paper type selection enabled
8	48	Cut method is determined according to the cut command.
	49 (Default)	Partial cut is performed regardless of cut command. (full but by command: enabled).

\*\*\* Default setting of MSW4-4 depends on the model. Thermal paper is the default of the standard model.

\*\*\* MSW 4-5 is valid only when black mark/label is set. If MSW4-4 is set for thermal paper, it is invalid

\*\*\* MSW4-8 is invalid when black mark/label is selected. Cut type for black mark/label paper is only full cut.

### • Setting MSW 5 (a=5)

n	b (Set Value)	Function
1	49 (Default)	Reserved
2	48 (Default)	Reserved
3	48	USB mode virtual serial.
	49 (Default)	USB mode printer class.
4	48 (Default)	Reserved
5	48 (Default)	Reserved
6	48 (Default)	Reserved
7	48 (Default)	If PNE is released, Error LED is automatically turned off.
	49	Error LED is not turned off until the paper is exchanged (printer Cover is opened) even if PNE is released.
8	48 (Default)	Reserved

## CT-S300

### • Setting MSW 1 (a=1)

n	b (Set Value)	Function
1	48 (Default)	Reports the power on.
	49	Does not report power on.
2	48 (Default)	Sets input buffer capacity to 4K bytes.
	49	Sets input buffer capacity to 45 bytes.
3	48 (Default)	Sets input buffer full and offline to be Busy.
	49	Sets to be busy with input buffer full.
4	48 (Default)	At the occurrence of receiving error, replaces the data with "?".
	49	At the occurrence of receiving error, ignores the data.
5	48 (Default)	Disables CR (ODH).
	49	Enables CR (ODH).
6	48 (Default)	Reserved
7	48 (Default)	Does not reset at serial I/F pin 6.
	49	Resets at serial I/F pin 6.
8	48 (Default)	Does not reset at serial I/F pin 25.
	49	Resets sat serial I/F pin 25.

### • Setting MSW 2 (a=2)

n	b (Set Value)	Function
1	49 (Default)	Reserved
2	48	Disables auto cutter.
	49 (Default)	Enables auto cutter.
3	48 (Default)	Enables stored printing.
	49	Disables stored printing.
4	48 (Default)	Immediately after digit reaches full, line-feed is taken.
	49	Immediately after digit reaches full, data wait is taken.
5	48 (Default)	After cover close and PE recovery, prints as it is.
	49	After cover close and PE recovery, prints from the beginning using PAGE MODE, barcode, image, double-height printing, etc. as a unit.
6	48(Default)	Sets paper width to 80 mm.
	49	Sets paper width to 58 mm.
7	48(Default)	Reserved
8	48(Default)	Enables PNE.
	49	Disables PNE.

### • Setting MSW 3 (a=3)

n	b (Set Value)	Function
1	48 (Default)	After clearing cutter error, can be restored by Feed SW.
	49	After clearing cutter error, cannot be restored by Feed SW.
2	48(Default)	When selecting cover open error as recoverable error, recovered by cover close.
	49	When selecting cover open error as recoverable error, recovered by command.
3	48 (Default)	Resets with parallel pin 31.
	49	Does not reset with parallel pin 31.
4	48(Default)	Uses thermal paper.
	49	Uses Black mark paper.
5	48(Default)	Used with 48/32 print columns.
	49	Used with 42/30 print columns.
6	48 (Default)	Reserved
7	48 (Default)	Sets EPSON compatible mode.
	49	Sets CBM1000-compatible mode.
8	48 (Default)	Sets cover open error during printing to be auto recovery error.
	49	Sets cover open error during printing to be recoverable error.

## CT-S300

- Setting MSW 4 (a=4)

n	b (Set Value)	Function
1	48 (Default)	At the selection of Black mark paper, disables auto end-measurement.
	49	At the selection of Black mark paper, enables auto end-measurement.
2	48(Default)	At the selection of Black mark paper, sets sensor position to be on the printing side.
	49	At the selection of Black mark paper, sets sensor position to be on the back of the printing side.
3	48 (Default)	Reserved
4	48 (Default)	Reserved
5	48 (Default)	Reserved
6	48 (Default)	Reserved
7	48 (Default)	Reserved
8	48 (Default)	Forcible partial cut disabled.
	49	Forcible partial cut enabled (full cut by command: enabled).

\* MSW 4-1, -2 are valid when MSW 3-4 is ON.



## CT-S310

### • Setting MSW 1 (a=1)

n	b (Set Value)	Function
1	48 (Default)	Reports the power on.
	49	Does not report power on.
2	48 (Default)	Sets input buffer capacity to 4K bytes.
	49	Sets input buffer capacity to 45 bytes.
3	48 (Default)	Sets input buffer full and offline to be Busy.
	49	Sets to be busy with input buffer full.
4	48 (Default)	At the occurrence of receiving error, replaces the data with "?".
	49	At the occurrence of receiving error, ignores the data.
5	48 (Default)	Disables CR (ODH).
	49	Enables CR (ODH).
6	48 (Default)	Reserved
7	48 (Default)	Does not reset at serial I/F pin 6.
	49	Resets at serial I/F pin 6.
8	48 (Default)	Does not reset at serial I/F pin 25.
	49	Resets sat serial I/F pin 25.

### • Setting MSW 2 (a=2)

n	b (Set Value)	Function
1	49 (Default)	Reserved
2	48	Disables auto cutter.
	49 (Default)	Enables auto cutter.
3	48 (Default)	Enables stored printing.
	49	Disables stored printing.
4	48 (Default)	Immediately after digit reaches full, line-feed is taken.
	49	Immediately after digit reaches full, data wait is taken.
5	48 (Default)	After cover close and PE recovery, prints as it is.
	49	After cover close and PE recovery, prints from the beginning using PAGE MODE, barcode, image, double-height printing, etc. as a unit.
6	48 (Default)	Sets paper width to 80 mm.
	49	Sets paper width to 58 mm.
7	48 (Default)	Reserved
8	48 (Default)	Enables PNE.
	49	Disables PNE.

### • Setting MSW 3 (a=3)

n	b (Set Value)	Function
1	48 (Default)	After clearing cutter error, can be restored by Feed SW.
	49	After clearing cutter error, cannot be restored by Feed SW.
2	48 (Default)	Reserved
3	48 (Default)	Resets with parallel pin 31.
	49	Does not reset with parallel pin 31.
4	48 (Default)	Uses thermal paper.
	49	Uses Black mark paper.
5	48 (Default)	Used with 48/32 print columns.
	49	Used with 42/30 print columns.
6	48 (Default)	Reserved
7	48 (Default)	Sets EPSON compatible mode.
	49	Sets CBM1000-compatible mode.
8	48 (Default)	Sets cover open error during printing to be auto recovery error.
	49	Sets cover open error during printing to be recoverable error.

### • Setting MSW 4 (a=4)

n	b (Set Value)	Function
1	48 (Default)	At the selection of Black mark paper, disables auto end-measurement.
	49	At the selection of Black mark paper, enables auto end-measurement.
2	48	At the selection of Black mark paper, sets sensor position to be on the printing side.
	49 (Default)	At the selection of Black mark paper, sets sensor position to be on the back of the printing side.
3	48	Paper heading cut disabled.
	49 (Default)	Paper heading cut enabled.
4	48 (Default)	Reserved
5	48 (Default)	Reserved
6	48 (Default)	Reserved
7	48 (Default)	Reserved
8	48	Forcible partial cut disabled.
	49 (Default)	Forcible partial cut enabled (full but by command: enabled).

\* MSW 4-1, -2 are valid when MSW 3-4 is ON.

**CT-S310**

- Setting MSW 5 (a=5)

<b>n</b>	<b>b (Set Value)</b>	<b>Function</b>
1	48 (Default)	Buzzer sound enabled.
	49	Buzzer sound disabled.
2	48 (Default)	Reserved
3	48	USB mode virtual serial.
	49 (Default)	USB mode printer class.
4	48 (Default)	Reserved
5	48 (Default)	Reserved
6	48 (Default)	Reserved
7	48 (Default)	If PNE is released, Error LED is automatically turned off.
	49	Error LED is not turned off until the paper is exchanged (printer cover is opened) even if PNE is released.
8	48 (Default)	Reserved

## CT-S310II

### • Setting MSW 1 (a=1)

n	b (Set Value)	Function
1	48 (Default)	Reports the power on.
	49	Does not report power on.
2	48 (Default)	Sets input buffer capacity to 4K bytes.
	49	Sets input buffer capacity to 45 bytes.
3	48 (Default)	Sets input buffer full and offline to be Busy.
	49	Sets to be busy with input buffer full.
4	48 (Default)	At the occurrence of receiving error, replaces the data with "?".
	49	At the occurrence of receiving error, ignores the data.
5	48 (Default)	Disables CR (ODH).
	49	Enables CR (ODH).
6	48 (Default)	Reserved
7	48 (Default)	Does not reset at serial I/F pin 6.
	49	Resets at serial I/F pin 6.
8	48 (Default)	Does not reset at serial I/F pin 25.
	49	Resets sat serial I/F pin 25.

\* With MSW1-2, parallel I/F (4K fixed) and USB I/F (16K fixed) are disabled. With serial I/F, 45 bytes are enabled only when DMA control (MSW7-6) is disabled.

### • Setting MSW 2 (a=2)

n	b (Set Value)	Function
1	49 (Default)	Reserved
2	48	Disables auto cutter.
	49 (Default)	Enables auto cutter.
3	48 (Default)	Enables stored printing.
	49	Disables stored printing.
4	48 (Default)	Immediately after digit reaches full, line-feed is taken.
	49	Immediately after digit reaches full, data wait is taken.
5	48 (Default)	After cover close and PE recovery, prints as it is.
	49	After cover close and PE recovery, prints from the beginning using PAGE MODE, barcode, image, double-height printing, etc. as a unit.
6	48 (Default)	Reserved
7	48 (Default)	Reserved
8	48 (Default)	Enables PNE.
	49	Disables PNE.

### • Setting MSW 3 (a=3)

n	b (Set Value)	Function
1	48 (Default)	After clearing cutter error, can be restored by Feed SW.
	49	After clearing cutter error, cannot be restored by Feed SW.
2	49 (Default)	Reserved
3	48 (Default)	Reserved
4	48 (Default)	Reserved
5	48 (Default)	Reserved
6	48 (Default)	Reserved
7	48 (Default)	Sets EPSON compatible mode.
	49	Sets CBM1000-compatible mode.
8	48 (Default)	Sets cover open error during printing to be auto recovery error.
	49	Sets cover open error during printing to be recoverable error.

### • Setting MSW 4 (a=4)

n	b (Set Value)	Function
1	48 (Default)	Reserved
2	48 (Default)	Reserved
3	48	Feed & Cut at TOF disabled.
	49 (Default)	Feed & Cut at TOF enabled.
4	48 (Default)	Reserved
5	48 (Default)	Reserved
6	48 (Default)	Reserved
7	48 (Default)	Reserved
8	48	Cut method is determined according to the cut command.
	49 (Default)	Partial cut is performed regardless of cut command. (full but by command: enabled).

## CT-S310II

- Setting MSW 5 (a=5)

n	b (Set Value)	Function
1	48 (Default)	Buzzer sound enabled.
	49	Buzzer sound disabled.
2	48 (Default)	Basic calculation pitch (180 dpi / 360 dpi).
	49	Basic calculation pitch (203 dpi / 406 dpi).
3	48	USB mode virtual serial.
	49 (Default)	USB mode printer class.
4	48 (Default)	Reserved
5	48 (Default)	Reserved
6	48 (Default)	Reserved
7	48 (Default)	Reserved
8	48 (Default)	Reserved

- Setting MSW 6 (a=6)

n	b (Set Value)	Function
1	48 (Default)	Act for driver is enabled.
	49	Act for driver is disabled.
2	48 (Default)	Character space is set for 0.
	49	Character space is set for 1
3	48	USB Power Saving mode disabled
	49(Default)	USB Power Saving mode enabled
4	48 (Default)	Reserved
5	48 (Default)	Reserved
6	48 (Default)	Reserved
7	48 (Default)	Reserved
8	48 (Default)	Reserved

## CT-S2000

### • Setting MSW 1 (a=1)

n	b (Set Value)	Function
1	48 (Default)	Reports the power on.
	49	Does not report power on.
2	48 (Default)	Sets input buffer capacity to 4K bytes.
	49	Sets input buffer capacity to 45 bytes.
3	48 (Default)	Sets input buffer full and offline to be Busy.
	49	Sets to be busy with input buffer full.
4	48 (Default)	At the occurrence of receiving error, replaces the data with "?".
	49	At the occurrence of receiving error, ignores the data.
5	48 (Default)	Disables CR (ODH).
	49	Enables CR (ODH).
6	48 (Default)	Reserved
7	48 (Default)	Does not reset at serial I/F pin 6.
	49	Resets at serial I/F pin 6.
8	48 (Default)	Does not reset at serial I/F pin 25.
	49	Resets sat serial I/F pin 25.

\* With MSW1-2, parallel I/F (4K fixed) and USB I/F (16K fixed) are disabled. With serial I/F, 45 bytes are enabled only when DMA control (MSW7-6) is disabled.

### • Setting MSW 2 (a=2)

n	b (Set Value)	Function
1	49 (Default)	Reserved
2	48	Disables auto cutter.
	49 (Default)	Enables auto cutter.
3	48 (Default)	Enables stored printing.
	49	Disables stored printing.
4	48 (Default)	Immediately after digit reaches full, line-feed is taken.
	49	Immediately after digit reaches full, data wait is taken.
5	48 (Default)	After cover close and PE recovery, prints as it is.
	49	After cover close and PE recovery, prints from the beginning using PAGE MODE, barcode, image, double-height printing, etc. as a unit.
6	48 (Default)	Reserved
7	48 (Default)	Reserved
8	48 (Default)	Enables PNE.
	49	Disables PNE.

### • Setting MSW 3 (a=3)

n	b (Set Value)	Function
1	48 (Default)	After clearing cutter error, can be restored by Feed SW.
	49	After clearing cutter error, cannot be restored by Feed SW.
2	48 (Default)	Reserved
3	48 (Default)	Resets with parallel pin 31.
	49	Does not reset with parallel pin 31.
4	48 (Default)	Reserved
5	48 (Default)	Reserved
6	48 (Default)	Reserved
7	48 (Default)	Sets EPSON compatible mode.
	49	Sets CBM1000-compatible mode.
8	48 (Default)	Sets cover open error during printing to be auto recovery error.
	49	Sets cover open error during printing to be recoverable error.

### • Setting MSW 4 (a=4) (Standard model)

n	b (Set Value)	Function
1	48 (Default)	At the selection of Black mark/Label paper, disables auto end-measurement.
	49	At the selection of Black mark/Label paper, enables auto end-measurement.
2	48 (Default)	Finding top of form at power ON disabled.
	49	Finding top of form at power ON enabled.
3	48	Feed & Cut at TOF disabled.
	49 (Default)	Feed & Cut at TOF enabled.
4	48 (Default)	Reserved
5	48 (Default)	Reserved
6	48 (Default)	Reserved
7	48 (Default)	Reserved
8	48	Cut method is determined according to the cut command.
	49 (Default)	Partial cut is performed regardless of cut command. (full but by command: enabled).

## CT-S2000

### • Setting MSW 4 (a=4) (Black mark/Label model)

n	b (Set Value)	Function
1	48 (Default)	At the selection of Black mark/Label paper, enables auto end-measurement.
	49	At the selection of Black mark/Label paper, disables auto end-measurement.
2	48 (Default)	Finding top of form at power ON disabled.
	49	Finding top of form at power ON enabled.
3	48	Feed & Cut at TOF disabled.
	49 (Default)	Feed & Cut at TOF enabled.
4	48 (Default)	Uses thermal roll paper.
	49	Uses Black mark paper/ label paper.
5	48 (Default)	Detects paper position and black mark.
	49	Detects paper position and inter-label distance.
6	48 (Default)	Paper type selection disabled
	49	Paper type selection enabled
7	48 (Default)	Reserved
8	48	Cut method is determined according to the cut command.
	49 (Default)	Partial cut is performed regardless of cut command. (full but by command: enabled).

\* MSW 4-5 is valid only if black mark/label is set. If MSW4-4 is set for thermal paper, it is invalid

\* MSW4-8 is invalid when black mark/label is selected. Cut type for black mark/label paper is only full cut.

### • Setting MSW 5 (a=5)

n	b (Set Value)	Function
1	48 (Default)	Buzzer sound enabled.
	49	Buzzer sound disabled.
2	48 (Default)	Basic calculation pitch (180 dpi / 360 dpi).
	49	Basic calculation pitch (203 dpi / 406 dpi).
3	48	USB mode virtual serial.
	49 (Default)	USB mode printer class.
4	48 (Default)	Reserved
5	48 (Default)	Reserved
6	48 (Default)	High quality printing mode disabled
	49	High quality printing mode enabled
7	48 (Default)	Reserved
8	48 (Default)	Reserved

## CT-S4000

### • Setting MSW 1 (a=1)

n	b (Set Value)	Function
1	48 (Default)	Reports the power on.
	49	Does not report power on.
2	48 (Default)	Sets input buffer capacity to 4K bytes.
	49	Sets input buffer capacity to 45 bytes. (Note)
3	48 (Default)	Sets input buffer full and offline to be Busy.
	49	Sets to be busy with input buffer full.
4	48 (Default)	At the occurrence of receiving error, replaces the data with "?".
	49	At the occurrence of receiving error, ignores the data.
5	48 (Default)	Disables CR (ODH).
	49	Enables CR (ODH).
6	48 (Default)	Reserved
7	48 (Default)	Does not reset at serial I/F pin 6.
	49	Resets at serial I/F pin 6.
8	48 (Default)	Does not reset at serial I/F pin 25.
	49	Resets sat serial I/F pin 25.

### • Setting MSW 2 (a=2)

n	b (Set Value)	Function
1	49 (Default)	Reserved
2	48	Disables auto cutter.
	49 (Default)	Enables auto cutter.
3	48 (Default)	Enables stored printing.
	49	Disables stored printing.
4	48 (Default)	Immediately after digit reaches full, line-feed is taken.
	49	Immediately after digit reaches full, data wait is taken.
5	48 (Default)	After cover close and PE recovery, prints as it is.
	49	After cover close and PE recovery, prints from the beginning using PAGE MODE, barcode, image, double-height printing, etc. as a unit.
6	48 (Default)	Reserved
7	48 (Default)	Reserved
8	48 (Default)	Enables PNE.
	49	Disables PNE.

### • Setting MSW 3 (a=3)

n	b (Set Value)	Function
1	48 (Default)	After clearing cutter error, can be restored by Feed SW.
	49	After clearing cutter error, cannot be restored by Feed SW.
2	48 (Default)	Reserved
3	48 (Default)	Resets with parallel pin 31.
	49	Does not reset with parallel pin 31.
4	48 (Default)	Reserved
5	48 (Default)	Reserved
6	48 (Default)	Reserved
7	48 (Default)	Sets EPSON compatible mode.
	49	Sets CBM1000-compatible mode.
8	48 (Default)	Sets cover open error during printing to be auto recovery error.
	49	Sets cover open error during printing to be recoverable error.

## CT-S4000

### • Setting MSW 4 (a=4)

n	b (Set Value)	Function
1	48 (Default)	At the selection of Black mark paper/ label paper, enables auto end-measurement.
	49	At the selection of Black mark paper/ label paper, disables auto end-measurement.
2	48 (Default)	Setting the first position at power ON disabled.
	49	Setting the first position at power ON enabled.
3	48	Paper heading cut disabled.
	49 (Default)	Paper heading cut enabled.
4	48 (Default)	Uses thermal roll paper.
	49	Uses Black mark paper/ label paper.
5	48 (Default)	Detects paper position and black mark.
	49	Detects paper position and inter-label distance.
6	48 (Default)	Reserved
7	48 (Default)	Reserved
8	48	Forcible partial cut disabled.
	49 (Default)	Forcible partial cut enabled (full but by command: enabled).

\* Default setting of MSW4-4 depends on the model. Thermal paper is the default of the standard model.

\* MSW 4-5 is valid only for black mark/label model. If MSW4-4 is set for thermal paper, it is invalid

\* MSW4-8 is invalid when black mark/label is selected. Cut type for black mark/label paper is only full cut.

### • Setting MSW 5 (a=5)

n	b (Set Value)	Function
1	48 (Default)	Buzzer sound enabled.
	49	Buzzer sound disabled.
2	48 (Default)	Basic calculation pitch (180 dpi / 360 dpi).
	49	Basic calculation pitch (203 dpi / 406 dpi).
3	48	USB mode virtual serial.
	49 (Default)	USB mode printer class.
4	48 (Default)	Reserved
5	48 (Default)	Reports the power off.
	49	Does not report power off.
6	48 (Default)	Reserved
7	48 (Default)	Reserved
8	48 (Default)	Reserved



**CT-S801/CT-S851/CT-S601/CT-S651**

• Setting MSW 1 (a=1)

n	b (Set Value)	Function
1	48 (Default)	Reports the power on.
	49	Does not report power on.
2	48 (Default)	Sets input buffer capacity to 4K bytes.
	49	Sets input buffer capacity to 45 bytes.
3	48 (Default)	Sets input buffer full and offline to be Busy.
	49	Sets to be busy with input buffer full.
4	48 (Default)	At the occurrence of receiving error, replaces the data with "?".
	49	At the occurrence of receiving error, ignores the data.
5	48 (Default)	Disables CR (ODH).
	49	Enables CR (ODH).
6	48 (Default)	Reserved
7	48 (Default)	Does not reset at serial I/F pin 6.
	49	Resets at serial I/F pin 6.
8	48 (Default)	Does not reset at serial I/F pin 25.
	49	Resets sat serial I/F pin 25.

\* With MSW1-2, parallel I/F (4K fixed) and USB I/F (16K fixed) are disabled. With serial I/F, 45 bytes are enabled only when DMA control (MSW7-6) is disabled.

• Setting MSW 2 (a=2)

n	b (Set Value)	Function
1	49 (Default)	Reserved
2	48	Disables auto cutter.
	49 (Default)	Enables auto cutter.
3	48 (Default)	Enables stored printing.
	49	Disables stored printing.
4	48 (Default)	Immediately after digit reaches full, line-feed is taken.
	49	Immediately after digit reaches full, data wait is taken.
5	48 (Default)	After cover close and PE recovery, prints as it is.
	49	After cover close and PE recovery, prints from the beginning using PAGE MODE, barcode, image, double-height printing, etc. as a unit.
6	48 (Default)	Reserved
7	48 (Default)	Reserved
8	48 (Default)	Enables PNE.
	49	Disables PNE.

• Setting MSW 3 (a=3)

n	b (Set Value)	Function
1	48 (Default)	After clearing cutter error, can be restored by Feed SW.
	49	After clearing cutter error, cannot be restored by Feed SW.
2	48 (Default)	Reserved
3	48 (Default)	Resets with parallel pin 31.
	49	Does not reset with parallel pin 31.
4	48 (Default)	Reserved
5	48 (Default)	Reserved
6	48 (Default)	Reserved
7	48 (Default)	Sets EPSON compatible mode.
	49	Sets CBM1000-compatible mode.
8	48 (Default)	Sets cover open error during printing to be auto recovery error.
	49	Sets cover open error during printing to be recoverable error.

**CT-S801/CT-S851/CT-S601/CT-S601**

• Setting MSW 4 (a=4)

n	b (Set Value)	Function
1	48 (Default)	At the selection of Black mark/Label paper, disables auto end-measurement.
	49	At the selection of Black mark/Label paper, enables auto end-measurement.
2	48 (Default)	Finding top of form at power ON disabled.
	49	Finding top of form at power ON enabled.
3	48	Feed & Cut at TOF disabled.
	49 (Default)	Feed & Cut at TOF enabled.
4	48 (Default)	Uses Black mark paper/ label paper.
	49	Uses thermal roll paper.
5	48 (Default)	Detects paper position and black mark.
	49	Detects paper position and inter-label distance.
6	48 (Default)	Paper type selection disabled
	49	Paper type selection enabled
7	48 (Default)	Reserved
8	48	Cut method is determined according to the cut command.
	49 (Default)	Partial cut is performed regardless of cut command. (full but by command: enabled).

\* Default setting of MSW4-4 depends on the model. Thermal paper is the default of the standard model.

\* MSW 4-5 is valid only for black mark/label model. If MSW4-4 is set for thermal paper, it is invalid

\* MSW4-8 is invalid when black mark/label is selected. Cut type for black mark/label paper is only full cut.

• Setting MSW 5 (a=5)

n	b (Set Value)	Function
1	48 (Default)	Buzzer sound enabled.
	49	Buzzer sound disabled.
2	48 (Default)	Basic calculation pitch (180 dpi / 360 dpi).
	49	Basic calculation pitch (203 dpi / 406 dpi).
3	48	USB mode virtual serial.
	49 (Default)	USB mode printer class.
4	48 (Default)	Reserved
5	48 (Default)	Reserved
6	48 (Default)	Reserved
7	48 (Default)	Reserved
8	48 (Default)	Reserved

• Setting MSW 6 (a=6)

n	b (Set Value)	Function
1	48 (Default)	Act for driver is enabled.
	49	Act for driver is disabled.
2	48 (Default)	Character space is set for 0.
	49	Character space is set for 1
3	48 (Default)	Reserved
4	48 (Default)	Reserved
5	48 (Default)	Reserved
6	48 (Default)	Reserved
7	48 (Default)	Reserved
8	48 (Default)	Reserved

## BD2-2220

### • Setting MSW 1 (a=1)

n	b (Set Value)	Function
1	48 (Default)	Reports the power on.
	49	Does not report power on.
2	48 (Default)	Sets input buffer capacity to 4K bytes.
	49	Sets input buffer capacity to 45 bytes. (Note)
3	48 (Default)	Sets input buffer full and offline to be Busy.
	49	Sets to be busy with input buffer full.
4	48 (Default)	At the occurrence of receiving error, replaces the data with "?".
	49	At the occurrence of receiving error, ignores the data.
5	48 (Default)	Disables CR (ODH).
	49	Enables CR (ODH).
6	48 (Default)	Reserved
7	48 (Default)	Does not reset at serial I/F pin 6.
	49	Resets at serial I/F pin 6.
8	48 (Default)	Reserved

### • Setting MSW 2 (a=2)

n	b (Set Value)	Function
1	49 (Default)	Reserved
2	48 (Default)	Reserved
3	48 (Default)	Enables stored printing.
	49	Disables stored printing.
4	48 (Default)	Immediately after digit reaches full, line-feed is taken.
	49	Immediately after digit reaches full, data wait is taken.
5	48 (Default)	After head-down* and PE recovery, prints as it is.
	49	After head-down* and PE recovery, prints from the beginning using PAGE MODE, barcode, image, double-height printing, etc. as a unit.
6	49 (Default)	Reserved
7	48 (Default)	Reserved
8	48 (Default)	Reserved

### • Setting MSW 3 (a=3)

n	b (Set Value)	Function
1	48 (Default)	After clearing cutter error, can be restored by Feed SW.
	49	After clearing cutter error, cannot be restored by Feed SW.
2	48 (Default)	Reserved
3	48 (Default)	Resets with parallel pin 31.
	49	Does not reset with parallel pin 31.
4	48 (Default)	Reserved
5	48 (Default)	Reserved
6	48 (Default)	Reserved
7	48 (Default)	Reserved
8	48 (Default)	Sets head-up* error during printing to be auto recovery error.
	49	Sets head-up* error during printing to be recoverable error.

\* Name depends on a mechanism to use.

LT2X20 series: Head-down/Head-up

LT2X21 series: platen-close/platen-open

## PMU2XXX

### • Setting MSW 1 (a=1)

n	b (Set Value)	Function
1	48 (Default)	Reports the power on.
	49	Does not report power on.
2	48 (Default)	Sets input buffer capacity to 4K bytes.
	49	Sets input buffer capacity to 45 bytes. (Note)
3	48 (Default)	Sets input buffer full and offline to be Busy.
	49	Sets to be busy with input buffer full.
4	48 (Default)	At the occurrence of receiving error, replaces the data with "?".
	49	At the occurrence of receiving error, ignores the data.
5	48 (Default)	Disables CR (ODH).
	49	Enables CR (ODH).
6	48 (Default)	Reserved
7	48 (Default)	Does not reset at serial I/F pin 6.
	49	Resets at serial I/F pin 6.
8	48 (Default)	Reserved

### • Setting MSW 2 (a=2)

n	b (Set Value)	Function
1	49 (Default)	Reserved
2	48	Disables auto cutter.
	49(Default)	Enables auto cutter.
3	48 (Default)	Enables stored printing.
	49	Disables stored printing.
4	48 (Default)	Immediately after digit reaches full, line-feed is taken.
	49	Immediately after digit reaches full, data wait is taken.
5	48 (Default)	After head-down* and PE recovery, prints as it is.
	49	After head-down* and PE recovery, prints from the beginning using PAGE MODE, barcode, image, double-height printing, etc. as a unit.
6	48	Sets paper width to 80 mm
	49	Sets paper width to 58(60) mm
7	48 (Default)	Reserved
8	48	Enables PNE.
	49 (Default)	Disables PNE.

### • Setting MSW 3 (a=3)

n	b (Set Value)	Function
1	48 (Default)	After clearing cutter error, can be restored by Feed SW.
	49	After clearing cutter error, cannot be restored by Feed SW.
2	48 (Default)	Reserved
3	48 (Default)	Resets with parallel pin 31.
	49	Does not reset with parallel pin 31.
4	48 (Default)	Uses thermal paper
	49	Uses Black mark paper
5	48 (Default)	Reserved
6	48 (Default)	Reserved
7	48 (Default)	Reserved
8	48 (Default)	Sets platen-open error during printing to be auto recovery error.
	49	Sets platen-open error during printing to be recoverable error.

### • Setting MSW 4 (a=4)

n	b (Set Value)	Function
1	48	At the selection of Black mark paper, disables auto end-measurement.
	49 (Default)	At the selection of Black mark paper, enables auto end-measurement.
2	48	At the selection of Black mark paper, sets sensor position to be on the printing side
	49 (Default)	At the selection of Black mark paper, sets sensor position to be on the back of the printing side
3	48	Paper heading cut disabled.
	49 (Default)	Paper heading cut enabled.
4	48	Base style is PMU2XX0/PMU2XX2.
	49	Base style is PMU2XX1.
5	48	Mechanism name is LT-23XX.
	49	Mechanism name is LT-22XX.
6	48 (Default)	Reserved
7	48 (Default)	Reserved
8	48(Default)	Forcible partial cut disabled.
	49	Forcible partial cut enabled (full cut by command: enabled).

\* MSW 4-1, -2 are valid when MSW 3-4 is ON.

## PMU2XXX

Setting MSW 5 (a=5)

<b>n</b>	<b>b (Set Value)</b>	<b>Function</b>
1	48 (Default)	Reserved
2	48 (Default)	Reserved
3	48 (Default)	Reserved
4	48 (Default)	Reserved
5	48 (Default)	Reserved
6	48	It is priority of the print quality.
	49 (Default)	Priority of the print speed.
7	48 (Default)	Reserved
8	48 (Default)	Reserved

## PMU2XXXII

### • Setting MSW 1 (a=1)

n	b (Set Value)	Function
1	48 (Default)	Reports the power on.
	49	Does not report power on.
2	48 (Default)	Sets input buffer capacity to 4K bytes.
	49	Sets input buffer capacity to 45 bytes. (Note)
3	48 (Default)	Sets input buffer full and offline to be Busy.
	49	Sets to be busy with input buffer full.
4	48 (Default)	At the occurrence of receiving error, replaces the data with "?".
	49	At the occurrence of receiving error, ignores the data.
5	48 (Default)	Disables CR (ODH).
	49	Enables CR (ODH).
6	48 (Default)	Reserved
7	48 (Default)	Does not reset at serial I/F pin 6.
	49	Resets at serial I/F pin 6.
8	48 (Default)	Reserved

### • Setting MSW 2 (a=2)

n	b (Set Value)	Function
1	49 (Default)	Reserved
2	48	Disables auto cutter.
	49(Default)	Enables auto cutter.
3	48 (Default)	Enables stored printing.
	49	Disables stored printing.
4	48 (Default)	Immediately after digit reaches full, line-feed is taken.
	49	Immediately after digit reaches full, data wait is taken.
5	48 (Default)	After head-down* and PE recovery, prints as it is.
	49	After head-down* and PE recovery, prints from the beginning using PAGE MODE, barcode, image, double-height printing, etc. as a unit.
6	48	Sets paper width to 80 mm.
	49	Sets paper width to 58(60) mm.
7	48 (Default)	Reserved
8	48	Enables PNE.
	49 (Default)	Disables PNE.

### • Setting MSW 3 (a=3)

n	b (Set Value)	Function
1	48 (Default)	After clearing cutter error, can be restored by Feed SW.
	49	After clearing cutter error, cannot be restored by Feed SW.
2	48 (Default)	Reserved
3	48 (Default)	Resets with parallel pin 31.
	49	Does not reset with parallel pin 31.
4	48 (Default)	Uses thermal paper.
	49	Uses Black mark paper.
5	48(Default)	Used with 48/32 print columns.
	49	Used with 42/30 print columns.
6	48 (Default)	Reserved
7	48 (Default)	Sets EPSON compatible mode.
	49	Sets CBM1000-compatible mode.
8	48 (Default)	Sets platen-open error during printing to be auto recovery error.
	49	Sets platen-open error during printing to be recoverable error.

## PMU2XXXII

### • Setting MSW 4 (a=4)

n	b (Set Value)	Function
1	48	At the selection of Black mark paper, disables auto end-measurement.
	49 (Default)	At the selection of Black mark paper, enables auto end-measurement.
2	48	At the selection of Black mark paper, sets sensor position to be on the printing side.
	49 (Default)	At the selection of Black mark paper, sets sensor position to be on the back of the printing side.
3	48	Paper heading cut disabled.
	49 (Default)	Paper heading cut enabled.
4	48	Base style is PMU2XX0/PMU2XX2.
	49	Base style is PMU2XX1.
5	48	Mechanism name is LT-23XX.
	49	Mechanism name is LT-22XX.
6	48 (Default)	Reserved
7	48 (Default)	Reserved
8	48(Default)	Forcible partial cut disabled.
	49	Forcible partial cut enabled (full cut by command: enabled).

\* MSW 4-1, -2 are valid when MSW 3-4 is ON.

### Setting MSW 5 (a=5)

n	b (Set Value)	Function
1	48 (Default)	Reserved
2	48 (Default)	Reserved
3	48	USB mode virtual serial.
	49 (Default)	USB mode printer class.
4	48 (Default)	Reserved
5	48 (Default)	Reserved
6	48 (Default)	It is priority of the print quality.
	49	Priority of the print speed.
7	48 (Default)	Reserved
8	48 (Default)	Reserved

## PMU2300III

### • Setting MSW 1 (a=1)

n	b (Set Value)	Function
1	48 (Default)	Reports the power on.
	49	Does not report power on.
2	48 (Default)	Sets input buffer capacity to 4K bytes.
	49	Sets input buffer capacity to 45 bytes. (Note)
3	48 (Default)	Sets input buffer full and offline to be Busy.
	49	Sets to be busy with input buffer full.
4	48 (Default)	At the occurrence of receiving error, replaces the data with "?".
	49	At the occurrence of receiving error, ignores the data.
5	48 (Default)	Disables CR (ODH).
	49	Enables CR (ODH).
6	48 (Default)	Reserved
7	48 (Default)	Does not reset at serial I/F pin 6.
	49	Resets at serial I/F pin 6.
8	48 (Default)	Reserved

### • Setting MSW 2 (a=2)

n	b (Set Value)	Function
1	49 (Default)	Reserved
2	48	Disables auto cutter.
	49 (Default)	Enables auto cutter.
3	48 (Default)	Enables stored printing.
	49	Disables stored printing.
4	48 (Default)	Immediately after digit reaches full, line-feed is taken.
	49	Immediately after digit reaches full, data wait is taken.
5	48 (Default)	After platen-close and PE recovery, prints as it is.
	49	After platen-close and PE recovery, prints from the beginning using PAGE MODE, barcode, image, double-height printing, etc. as a unit.
6	48 (Default)	Reserved
7	48 (Default)	Reserved
8	48	Enables PNE.
	49 (Default)	Disables PNE.

### • Setting MSW 3 (a=3)

n	b (Set Value)	Function
1	48 (Default)	After clearing cutter error, can be restored by Feed SW.
	49	After clearing cutter error, cannot be restored by Feed SW.
2	48 (Default)	Reserved
3	48 (Default)	Resets with parallel pin 31.
	49	Does not reset with parallel pin 31.
4	48 (Default)	Uses thermal paper.
	49	Uses Black mark paper.
5	48 (Default)	Used with 48 print columns.
	49	Used with 42 print columns.
6	48 (Default)	Reserved
7	48 (Default)	Sets EPSON compatible mode.
	49	Sets CBM1000-compatible mode.
8	48 (Default)	Sets platen-open error during printing to be auto recovery error.
	49	Sets platen-open error during printing to be recoverable error.

### • Setting MSW 4 (a=4)

n	b (Set Value)	Function
1	48	At the selection of Black mark paper, disables auto end-measurement.
	49 (Default)	At the selection of Black mark paper, enables auto end-measurement.
2	48	At the selection of Black mark paper, sets sensor position to be on the printing side.
	49 (Default)	At the selection of Black mark paper, sets sensor position to be on the back of the printing side.
3	48	Paper heading cut disabled.
	49 (Default)	Paper heading cut enabled.
4	48 (Default)	Reserved
5	48 (Default)	Reserved
6	48 (Default)	Reserved
7	48 (Default)	Reserved
8	48 (Default)	Forcible partial cut disabled.
	49	Forcible partial cut enabled (full cut by command: enabled).

\* MSW 4-1, -2 are valid when MSW 3-4 is ON.

## PMU2XXXIII



• Setting MSW 5 (a=5)

n	b (Set Value)	Function
1	48 (Default)	Reserved
2	48 (Default)	Reserved
3	48	USB mode virtual serial.
	49 (Default)	USB mode printer class.
4	48 (Default)	Reserved
5	48 (Default)	Reserved
6	48 (Default)	Faster printing mode
	49	Higher quality printing mode
7	48 (Default)	Reserved
8	48 (Default)	Reserved

• Setting MSW11 (a=11)

n	b (Set Value)	Function
1	48	Presenter function disabled
	49	Presenter function enabled
2	48 (Default)	Retract function disabled
	49	Retract function enabled
3	48 (Default)	Retract direction = Rear
	49	Retract direction = Front
4	48	Store and eject = disabled
	49 (Default)	Store and eject = enabled
5	48	No print with paper = disabled
	49 (Default)	No print with paper = enabled
6	48 (Default)	Minimum receipt length = 75mm
	49	Minimum receipt length = 120mm
7	48 (Default)	Reserved
8	48 (Default)	Reserved

• Setting MSW12 (a=12)

n	b (Set Value)	Function
1	48	Bezel function disabled
	49	Bezel function enabled
2	48	LED control disabled
	49 (Default)	LED control enabled
3	48 (Default)	Reserved
4	48 (Default)	Reserved
5	48 (Default)	Show Error by LED = disabled
	49	Show Error by LED = enabled
6	48	No print with paper = disabled
	49 (Default)	No print with paper = enabled
7	48 (Default)	Reserved
8	48 (Default)	Reserved

### CT-P29x series

- Setting MSW 1 (a=1)

n	b (Set Value)	Function
1	48 (Default)	Reports the power on.
	49	Does not report power on.
2	48 (Default)	Sets input buffer capacity to 4K bytes.
	49	Sets input buffer capacity to 45 bytes. (Note)
3	48 (Default)	Sets input buffer full and offline to be Busy.
	49	Sets to be busy with input buffer full.
4	48 (Default)	At the occurrence of receiving error, replaces the data with "?".
	49	At the occurrence of receiving error, ignores the data.
5	48 (Default)	Disables CR (ODH).
	49	Enables CR (ODH).
6	48 (Default)	Reserved
7	48 (Default)	Does not reset at serial I/F pin 6.
	49	Resets at serial I/F pin 6.
8	48 (Default)	Reserved

- Setting MSW 2 (a=2)

n	b (Set Value)	Function
1	49 (Default)	Reserved
2	48	Disables auto cutter.
	49(Default)	Enables auto cutter.
3	48 (Default)	Enables stored printing.
	49	Disables stored printing.
4	48 (Default)	Immediately after digit reaches full, line-feed is taken.
	49	Immediately after digit reaches full, data wait is taken.
5	48 (Default)	After head-down* and PE recovery, prints as it is.
	49	After head-down* and PE recovery, prints from the beginning using PAGE MODE, barcode, image, double-height printing, etc. as a unit.
6	48	Sets paper width to 80 mm.
	49	Sets paper width to 58(60) mm.
7	48 (Default)	Reserved
8	48	Enables PNE.
	49 (Default)	Disables PNE.

- Setting MSW 3 (a=3)

n	b (Set Value)	Function
1	48 (Default)	After clearing cutter error, can be restored by Feed SW.
	49	After clearing cutter error, cannot be restored by Feed SW.
2	48 (Default)	Reserved
3	48 (Default)	Resets with parallel pin 31.
	49	Does not reset with parallel pin 31.
4	48 (Default)	Uses thermal paper.
	49	Uses Black mark paper.
5	48(Default)	Used with 48 print columns
	49	Used with 32 print columns.
6	48 (Default)	Reserved
7	48 (Default)	Sets EPSON compatible mode.
	49	Sets CBM1000-compatible mode.
8	48 (Default)	Sets platen-open error during printing to be auto recovery error.
	49	Sets platen-open error during printing to be recoverable error.

### CT-P29x series

- Setting MSW 4 (a=4)

n	b (Set Value)	Function
1	48	Reserved
	49	Reserved
2	48	Reserved
	49 (Default)	Reserved
3	48	Paper heading cut disabled.
	49 (Default)	Paper heading cut enabled.
4	48	Reserved
	49	Reserved
5	48	Reserved
	49	Reserved
6	48	Reserved
7	48	Reserved
8	48(Default)	Forcible partial cut disabled.
	49	Forcible partial cut enabled (full cut by command: enabled).

\* MSW 4-1, -2 are valid when MSW 3-4 is ON.

### Setting MSW 5 (a=5)

n	b (Set Value)	Function
1	48 (Default)	Reserved
2	48 (Default)	Reserved
3	48	Reserved
	49	Reserved
4	48 (Default)	Reserved
5	48 (Default)	Reserved
6	48	Priority of the print speed.
	49 (Default)	It is priority of the print quality.
7	48 (Default)	Reserved
8	48 (Default)	Reserved

## fn=4: Function 4 Sending the Set Memory Switch Value

# GS ( E pL pH fn a

**[Code]** <1D>H<28>H<45>H<pL><pH><fn><a>

**[Range]** (pL+pH×256)=2

fn=4

**CT-S280/BD2-2220**

a=1, 2, 3

**CT-S300**

a=1, 2, 3, 4

**CT-S281/CT-S310/CT-S2000/CT-S4000/PMU2XXX/PMU2XXXII**

**CT-P29x series**

a=1, 2, 3, 4, 5

**CT-S801/CT-S851/CT-S601/CT-S601/CT-S310II**

a=1, 2, 3, 4, 5, 6

**PMU2300III**

a=1, 2, 3, 4, 5, 11, 12

**[Outline]** **[The specification which is common to the model]**

- Sends the content of MSW set in "a".

	Hex.	No. of Data
Header	37H	1
ID	21H	1
Data	30H or 31H	8
NULL	00H	1

- Sends the set value of data in 8-byte data raw in order of bits 8, 7, 6  
 OFF: 30H ("0")  
 ON : 31H ("1")

**[Caution]** **[The specification which depend on the model]**

**CT-S310/CT-S2000/CT-S4000/CT-S801/CT-S601**

- MSW7 to MSW10 cannot be sent by this command.
- Transmission is available by <Sending preset customize value>.

**fn=5: Function 5 Setting Customized Value**

# GS ( E pL pH fn [a1 n1L n1H] ... [ak nkL nkH]

<b>[Code]</b>	<1D>H<28>H<45>H<pL><pH><fn> [<a1><n1L><n1H>] ... [<ak><nkL><nkH>]
<b>[Range]</b>	<p>4≤(pL+pH×256)≤65535 fn=5 1≤(nL+nH×256)≤65535</p> <p><b>CT-S280</b> a=5, 6, 116, 201, 202, 214, 216, 217, 218</p> <p><b>CT-S281</b> a=5, 6, 116, 202, 213, 214, 216, 217, 218, 226</p> <p><b>CT-S300/CT-S310</b> a=3, 5, 6, 97, 116, 201, 202, 220, 221, 222, 223, 224, 225</p> <p><b>CT-S310II</b> a=1, 2, 3, 5, 6, 202, 212, 213, 214, 216, 217, 218, 244,245, 246, 247, 248</p> <p><b>CT-S2000</b> a=1, 2, 3, 5, 6, 116, 201, 202, 212, 213, 214, 220, 221, 222, 223, 224, 225</p> <p><b>CT-S4000</b> a=1, 2, 3, 5, 6, 116, 201, 202, 212, 213, 214</p> <p><b>CT-S801</b> a=1, 2, 3, 5, 6, 116, 201, 202, 212, 213, 214, 216, 217, 218, 220, 221, 222, 223, 224, 225, 230, 231, 232, 233, 234, 240, 241, 242, 243, 244,245, 246, 247, 248</p> <p><b>CT-S851</b> a=1, 2, 3, 5, 6, 116, 201, 202, 212, 213, 214, 216, 217, 218, 220, 221, 222, 223, 224, 225, 230, 231, 232, 233, 240, 241, 242, 243</p> <p><b>CT-S601/CT-S651</b> a=1, 2, 3, 5, 6, 116, 201, 202, 212, 213, 214, 216, 217, 218, 220, 221, 222, 223, 224, 225, 240, 240, 241, 242, 243</p> <p><b>BD2-2220</b> a=5, 6, 201, 202</p> <p><b>PMU 2XXX/PMU2XXXII</b> a=5, 6,201, 202, 220, 221, 222, 223, 224, 225 *a=220, 221, 222, 223, 224, and 225 are supported with only label/BM model.</p> <p><b>PMU2300III</b> a=5, 6, 130, 131, 132, 133, 134, 135, 136, 202, 213, 214, 216, 217, 218, 220, 221, 222, 223, 224, 225 *a=220, 221, 222, 223, 224, 225 are supported with only BM model.</p> <p><b>CT-P29x series</b> a=5, 6, 213, 214, 216, 217, 218</p>

**[Outline]****[The specification which is common to the model]**

- Sets the customized value set in "a" to (nL+nH×256).

<b>a</b>	<b>Function</b>
1	Specifies user NV memory capacity.
2	Specifies the memory capacity of NV graphics.
3	Selects paper width.
5	Selects printing density.
6	Selects printing speed.
97	Sets the number of divisions for conducting head
116	Selects printing color.
130	Sets the auto retraction time length
131	Sets the time length of bezel LED ON at waiting
132	Sets the time length of bezel LED ON at blinking
133	Sets the time length of bezel LED OFF at blinking
134	Sets the state of bezel LED at waiting
135	Sets the state of bezel LED at printing
136	Sets the state of bezel LED at ejecting
201	Sets ACK output position (only parallel I/F).
202	Selects input buffer full Busy output/cancel timing (idle capacity).
212	Selects DMA (Direct Memory Access) control of serial communication.
213	Selects the flow control when virtual COM is set.
214	Select the enable/disable of Kanji.
216	Selects JIS / Shift JIS
217	Selects the international character set
218	Selects the codepage
220	Sets the maximum BM width.
221	Sets the maximum BM page length.
222	Adjusts the distance of BM header.
223	Adjusts the distance of BM footer.
224	Adjusts the length of BM cut distance.
225	Adjusts the length of BM head distance.
226	Sets the wait time for manual cut
230	Selects the language of LCD message
231	Selects the enable/disable of LCD download message
232	Selects the LCD auto Off time
233	Selects the enable/disable of key lock
234	Selects the direction of LCD message
240	Sets the buzzer volume
241	Sets the max dot number for one head division
242	Sets the max dot number for Powered USB
243	Select the mechanism type

**[Caution]****[The specification which is common to the model]**

- This function operates only in printer function setting mode.
- The value changed by this command is enabled by execution of function 2 (fn = 2: End of printer function setting mode) (Recommended)

**CT-S280**

- a=5: Sets printing density to the level specified by (nL+nH×256).

(nL+nH×256)	Printing Density
65530	70%
65531	75%
65532	80%
65533	85%
65534	90%
65535	95%
0(Default)	100%
1	105%
2	110%
3	115%
4	120%
5	125%
6	130%
7	135%
8	140%

- a=6: Sets printing speed to the value specified by (nL+nH×256).

(nL+nH×256)	Printing Speed
1	Printing speed level 1 (84%)
2	Printing speed level 2 (86%)
3	Printing speed level 3 (88%)
4	Printing speed level 4 (90%)
5	Printing speed level 5 (92%)
6	Printing speed level 6 (94%)
7	Printing speed level 7 (96%)
8	Printing speed level 8 (98%)
9 (Default)	Printing speed level 9 (100%)

- a=116: Sets the paper specified by (nL+nH×256).

(nL+nH×256)	Paper
1 (Default)	Specified single color paper.
257	Recommended 2-color paper5

- a=201: Outputs ACK to the position specified by (nL+nH×256).

(nL+nH×256)	ACK Output Position
1 (Default)	ACK-in-Busy
2	ACK-while-Busy
3	ACK-after-Busy

- a=202: Controls input buffer full Busy with the value selected by (nL+nH×256) and controls Busy with output/cancel timing (remaining capacity).

(nL+nH×256)	When Input Buffer Capacity "Small" is Set		When Input Buffer Capacity 4K Bytes (Large) is Set	
	Output	Cancel	Output	Cancel
1 (Default)	16	26	128	256
2	16	40	128	512
3	30	50	72	256
4	30	60	72	512

- XON/XOFF is also output by the establishment of conditions.
- Ignores the data received when input buffer idle capacity is 0.

**CT-S280**

- a=214: Select the enable/disable of Kanji specified by (nL+nH×256)

(nL+nH×256)	Kanji
1	Invalid(OFF)
2(Default)	Valid(ON)

- a=216: Select the JIS/Shift JIS specified by (nL+nH×256)

(nL+nH×256)	JIS/Shift JIS
1(Default)	JIS (ON)
2	Shift JIS(OFF)

- a=217: Select the international character set specified by (nL+nH×256)

(nL+nH×256)	Int'l Char set	(nL+nH×256)	Int'l Char set
1(Default)	U.S.A.	9	Japan
2	France	10	Norway
3	Germany	11	Denmark II
4	U.K.	12	Spain II
5	Denmark I	13	Latin America
6	Sweden	14	Korea
7	Italy		
8	Spain I		

- a=218: Select the codepage specified by (nL+nH×256)

(nL+nH×256)	Codepage	(nL+nH×256)	Codepage
1(Default)	Codepage PC437	8	Codepage PC866
2	Katakana	9	Codepage PC857
3	Codepage PC850	10	WPC1252
4	Codepage PC860	11	Space page
5	Codepage PC863	12	Codepage PC864
6	Codepage PC865	13	Thai code18
7	Codepage PC852		



## CT-S281

- a=5: Sets printing density to the level specified by (nL+nH×256).

(nL+nH×256)	Printing Density
65530	70%
65531	75%
65532	80%
65533	85%
65534	90%
65535	95%
0(Default)	100%
1	105%
2	110%
3	115%
4	120%
5	125%
6	130%
7	135%
8	140%

- a=6: Sets printing speed to the value specified by (nL+nH×256).

(nL+nH×256)	Printing Speed
1	Printing speed level 1 (84%)
2	Printing speed level 2 (86%)
3	Printing speed level 3 (88%)
4	Printing speed level 4 (90%)
5	Printing speed level 5 (92%)
6	Printing speed level 6 (94%)
7	Printing speed level 7 (96%)
8	Printing speed level 8 (98%)
9 (Default)	Printing speed level 9 (100%)

- a=116: Sets the paper specified by (nL+nH×256).

(nL+nH×256)	Paper
1 (Default)	Specified single color paper.
257	Recommended 2-color paper5

- a=202: Controls input buffer full Busy with the value selected by (nL+nH×256) and controls Busy with output/cancel timing (remaining capacity).

(nL+nH×256)	When Input Buffer Capacity "Small" is Set		When Input Buffer Capacity 4K Bytes (Large) is Set	
	Output	Cancel	Output	Cancel
1 (Default)	16	26	128	256
2	16	40	128	512
3	30	50	72	256
4	30	60	72	512

- XON/XOFF is also output by the establishment of conditions.
- Ignores the data received when input buffer idle capacity is 0.
- a=213: Selects the flow control specified by (nL+nH×256) when virtual COM is set.

(nL+nH×256)	Flow control
1(Default)	PC setting
2	DTR/DSR
3	XON/XOFF

## CT-S281

- a=214: Select the enable/disable of Kanji specified by (nL+nH×256)

(nL+nH×256)	Kanji
1	Invalid(OFF)
2(Default)	Valid(ON)

- a=216: Select the JIS/Shift JIS specified by (nL+nH×256)

(nL+nH×256)	JIS/Shift JIS
1(Default)	JIS (ON)
2	Shift JIS(OFF)

- a=217: Select the international character set specified by (nL+nH×256)

(nL+nH×256)	Int'l Char set	(nL+nH×256)	Int'l Char set
1(Default)	U.S.A.	9	Japan
2	France	10	Norway
3	Germany	11	Denmark II
4	U.K.	12	Spain II
5	Denmark I	13	Latin America
6	Sweden	14	Korea
7	Italy	15	Croatia
8	Spain I	16	P.R. China

- a=218: Select the codepage specified by (nL+nH×256)

(nL+nH×256)	Codepage	(nL+nH×256)	Codepage
1(Default)	Codepage PC437	8	Codepage PC866
2	Katakana	9	Codepage PC857
3	Codepage PC850	10	WPC1252
4	Codepage PC860	11	Space page
5	Codepage PC863	12	Codepage PC864
6	Codepage PC865	13	Thai code18
7	Codepage PC852		

- a=226: Sets the wait time for manual cut by (nL+nH×256)  
if "0" is specified, printer wait until FEED is pressed.

$$0 \leq (nL+nH \times 256) \leq 1200$$

Unit: 1 second.

Default: 3 seconds.

**CT-S300**

- a=3: Sets paper width to the size specified by (nL+nH×256).

(nL+nH×256)	Paper Width
2	58mm
6 (Default)	80mm

- a=5: Sets printing density to the level specified by (nL+nH×256).

(nL+nH×256)	Printing Density
65530	70%
65531	75%
65532	80%
65533	85%
65534	90%
65535	95%
0(Default)	100%
1	105%
2	110%
3	115%
4	120%
5	125%
6	130%
7	135%
8	140%

- a=6: Sets printing speed to the value specified by (nL+nH×256).

(nL+nH×256)	Printing Speed
1	Printing speed level 1 (84%)
2	Printing speed level 2 (86%)
3	Printing speed level 3 (88%)
4	Printing speed level 4 (90%)
5	Printing speed level 5 (92%)
6	Printing speed level 6 (94%)
7	Printing speed level 7 (96%)
8	Printing speed level 8 (98%)
9(Default)	Printing speed level 9 (100%)

- a=97: Sets the number of divisions for conducting head specified by (nL+nH×256).

(nL+nH×256)	No. of Divisions for Conducting Head
2(Default)	2-division conducting
4	4-division conducting

- a=116: Sets the paper specified by (nL+nH×256).

(nL+nH×256)	Paper
1 (Default)	Specified single color paper.
257	Recommended 2-color paper5

- a=201: Outputs ACK to the position specified by (nL+nH×256).

(nL+nH×256)	ACK Output Position
1 (Default)	ACK-in-Busy
2	ACK-while-Busy
3	ACK-after-Busy

**CT-S300**

- a=202: Controls input buffer full Busy with the value selected by (nL+nH×256) and controls Busy with output/cancel timing (remaining capacity).

(nL+nH×256)	When Input Buffer Capacity "Small" is Set		When Input Buffer Capacity 4K Bytes (Large) is Set	
	Output	Cancel	Output	Cancel
1 (Default)	16	26	128	256
2	16	40	128	512
3	30	50	72	256
4	30	60	72	512

- XON/XOFF is also output by the establishment of conditions.
- Ignores the data received when input buffer idle capacity is 0.

- a=220: Sets the maximum width of black mark by the amount selected by (nL+nH×256)

$1 \leq (nL+nH \times 256) \leq 32767$   
 Unit: 1 dot  
 Initial value: 40 dots

- a=221: Sets the maximum length of black mark page with the value selected by (nL+nH×256).

$1 \leq (nL+nH \times 256) \leq 32767$   
 Unit: 1 dot  
 Initial value: 2360 dots

- a=222: Head margin set by the value selected by (nL+nH×256).

$1 \leq (nL+nH \times 256) \leq 32767$   
 Unit: 168dot  
 Initial value: 0dot

- a=223: Sets black mark bottom margin with the amount selected by (nL+nH×256).

$1 \leq (nL+nH \times 256) \leq 255$   
 Unit: 1 dot  
 Initial value: 34 dots

- a=224: Sets cut distance with the value selected by (nL+nH×256).

$1 \leq (nL+nH \times 256) \leq 255$   
 Unit: 1 dot  
 Initial value: 232 dots

- a=225: Sets head distance with the value selected by (nL+nH×256).

$1 \leq (nL+nH \times 256) \leq 255$   
 Unit: 1 dot  
 Initial value: 56 dots

### CT-S310

- a=3: Sets paper width to the size specified by (nL+nH×256).

(nL+nH×256)	Paper Width
2	58mm
6 (Default)	80mm

- a=5: Sets printing density to the level specified by (nL+nH×256).

(nL+nH×256)	Printing Density
65530	70%
65531	75%
65532	80%
65533	85%
65534	90%
65535	95%
0(Default)	100%
1	105%
2	110%
3	115%
4	120%
5	125%
6	130%
7	135%
8	140%

- a=6: Sets printing speed to the value specified by (nL+nH×256).

(nL+nH×256)	Printing Speed
1	Printing speed level 1 (84%)
2	Printing speed level 2 (86%)
3	Printing speed level 3 (88%)
4	Printing speed level 4 (90%)
5	Printing speed level 5 (92%)
6	Printing speed level 6 (94%)
7	Printing speed level 7 (96%)
8	Printing speed level 8 (98%)
9(Default)	Printing speed level 9 (100%)

- a=97: Sets the number of divisions for conducting head specified by (nL+nH×256).

(nL+nH×256)	No. of Divisions for Conducting Head
2(Default)	2-division conducting
4	4-division conducting

- a=116: Sets the paper specified by (nL+nH×256).

(nL+nH×256)	Paper
1 (Default)	Specified single color paper.
257	Recommended 2-color paper5

**CT-S310**

- a=202: Controls input buffer full Busy with the value selected by (nL+nH×256) and controls Busy with output/cancel timing (remaining capacity).

(nL+nH×256)	When Input Buffer Capacity "Small" is Set		When Input Buffer Capacity 4K Bytes (Large) is Set	
	Output	Cancel	Output	Cancel
1 (Default)	16	26	384	512
2	16	36	384	1024
3	8	26	256	384
4	8	36	256	512

- XON/XOFF is also output by the establishment of conditions.
- Ignores the data received when input buffer idle capacity is 0.

- a=220: Sets the maximum width of black mark by the amount selected by (nL+nH×256).

$1 \leq (nL+nH \times 256) \leq 32767$   
 Unit: 1 dot  
 Initial value: 40 dots

- a=221: Sets the maximum length of black mark page with the value selected by (nL+nH×256).

$1 \leq (nL+nH \times 256) \leq 32767$   
 Unit: 1 dot  
 Initial value: 2360 dots

- a=222: Head margin set by the value selected by (nL+nH×256).

$1 \leq (nL+nH \times 256) \leq 32767$   
 Unit: 168dot  
 Initial value: 0dot

- a=223: Sets black mark bottom margin with the amount selected by (nL+nH×256).

$1 \leq (nL+nH \times 256) \leq 255$   
 Unit: 1 dot  
 Initial value: 34 dots

- a=224: Sets cut distance with the value selected by (nL+nH×256).

$1 \leq (nL+nH \times 256) \leq 255$   
 Unit: 1 dot  
 Initial value: 232 dots

- a=225: Sets head distance with the value selected by (nL+nH×256).

$1 \leq (nL+nH \times 256) \leq 255$   
 Unit: 1 dot  
 Initial value: 56 dots

**CT-S310II**

- a=1: Sets the user NV memory capacity to the size specified by (nL+nH×256).

(nL+nH×256)	Memory Capacity
1	1K bytes
2	64K bytes
3	128K bytes
4(Default)	192K bytes

- a=2: Sets NV graphic memory capacity to the size specified by (nL+nH×256).

(nL+nH×256)	Memory Capacity
1	None
2	64K bytes
3	128K bytes
4	192K bytes
5	256K bytes
6	320K bytes
7(Default)	384K bytes

- a=3: Sets paper width to the size specified by (nL+nH×256).

(nL+nH×256)	Paper Width
1	58mm(360dot)
2	58mm(384dot)
3	58mm(420dot)
6	80mm(512dot)
7(Default)	80mm(576dot)
9	58mm(390dot)
10	80mm(546dot)

- a=5: Sets printing density to the level specified by (nL+nH×256).

(nL+nH×256)	Printing Density
65530	70%
65531	75%
65532	80%
65533	85%
65534	90%
65535	95%
0(Default)	100%
1	105%
2	110%
3	115%
4	120%
5	125%
6	130%
7	135%
8	140%

- a=6: Sets printing speed to the value specified by (nL+nH×256).

(nL+nH×256)	Printing Speed
1	Printing speed level 1 (84%)
2	Printing speed level 2 (86%)
3	Printing speed level 3 (88%)
4	Printing speed level 4 (90%)
5	Printing speed level 5 (92%)
6	Printing speed level 6 (94%)
7	Printing speed level 7 (96%)
8	Printing speed level 8 (98%)
9(Default)	Printing speed level 9 (100%)

**CT-S310II**

- a=202: Controls input buffer full Busy with the value selected by (nL+nH×256) and controls Busy with output/cancel timing (remaining capacity).

(nL+nH×256)	When Input Buffer Capacity "Small" is Set		When Input Buffer Capacity 4K Bytes (Large) is Set	
	Output	Cancel	Output	Cancel
1	16	26	128	256
2	16	40	128	512
3	30	50	72	256
4	30	60	72	512

- XON/XOFF is also output by the establishment of conditions.
- Ignores the data received when input buffer idle capacity is 0.

- a=212: Selects DMA (Direct Memory Access) control of serial communication specified by (nL+nH×256).

(nL+nH×256)	DMA control
1	Invalid
2(Default)	Valid

- a=213: Selects the flow control specified by (nL+nH×256) when virtual COM is set.

(nL+nH×256)	Flow control
1(Default)	PC setting
2	DTR/DSR
3	XON/XOFF

- a=214: Select the enable/disable of Kanji specified by (nL+nH×256)

(nL+nH×256)	Kanji
1	Invalid(OFF)
2(Default)	Valid(ON)

- a=216: Select the JIS/Shift JIS specified by (nL+nH×256)

(nL+nH×256)	JIS/Shift JIS
1(Default)	JIS
2	Shift JIS(CP932)
3	Shift JIS(X0213)

- a=217: Select the international character set specified by (nL+nH×256)

(nL+nH×256)	Int'l Char set	(nL+nH×256)	Int'l Char set
1(Default)	U.S.A.	9	Japan
2	France	10	Norway
3	Germany	11	Denmark II
4	U.K.	12	Spain II
5	Denmark I	13	Latin America
6	Sweden	14	Korea
7	Italy	15	Croatia
8	Spain I	16	P.R. China

- a=218: Select the codepage specified by (nL+nH×256)

(nL+nH×256)	Codepage	(nL+nH×256)	Codepage
1	Codepage PC437	8	Codepage PC866
2	Katakana	9	Codepage PC857
3	Codepage PC850	10	WPC1252
4	Codepage PC860	11	Space page
5	Codepage PC863	12	Codepage PC864
6	Codepage PC865	13	Thai code18
7	Codepage PC852		



**CT-S310II**

•a=244: Selects the top margin specified by (nL+nH×256)  
 (Small top margin = long back feed at printing start)

(nL+nH×256)	Top margin
1(Default)	11mm (No back feed)
2	3mm (8mm back feed)
3	4mm (7mm back feed)
4	5mm (6mm back feed)
5	6mm (5mm back feed)
6	7mm (4mm back feed)
7	8mm (3mm back feed)
8	9mm (2mm back feed)
9	10mm (1mm back feed)

•a=245: Selects the line gap reduction ratio specified by (nL+nH×256)

(nL+nH×256)	Rudction ratio of line gap
1(Default)	No reduction
2	Reduction to 3/4
3	Reduction to 2/3
4	Reduction to 1/2
5	Reduction to 1/3
6	Reduction to 1/4
7	Reduction to 1/5
8	No line gap

•a =246: Selects the mode to print compressed character specified by (nL+nH×256)

(nL+nH×256)	Character size compression ratio Vertical/Horizontal
1(Default)	100% / 100% (No compression)
2	75% / 100%
3	50% / 100%
4	100% / 75%
5	75% / 75%
6	50% / 75%

•a=247: Select the number of dot for auto side shift specified by (nL+nH×256)

(nL+nH×256)	Auto Side Shift
1(Default)	Invalid
2	1dot
3	2dot
4	3dot
5	4dot
6	5dot
7	6dot
8	7dot

•a=248: Selects the event for the buzzer activation specified by (nL+nH×256)

(nL+nH×256)	Buzzer enent
1	All events / errors
2(Default)	Except cover open
3	Except cover open / no paper

## CT-S2000

- a=1: Sets the user NV memory capacity to the size specified by (nL+nH×256).

(nL+nH×256)	Memory Capacity
1	1K bytes
2	64K bytes
3	128K bytes
4(Default)	192K bytes

- a=2: Sets NV graphic memory capacity to the size specified by (nL+nH×256).

(nL+nH×256)	Memory Capacity
1	None
2	64K bytes
3	128K bytes
4	192K bytes
5	256K bytes
6	320K bytes
7(Default)	384K bytes

- a=3: Sets paper width to the size specified by (nL+nH×256).

(nL+nH×256)	Paper Width
1	58mm(360dot)
2	58mm(384dot)
3	58mm(420dot)
4	58mm(432dot)
5	58mm(436dot)
6	80mm(512dot)
7(Default)	80mm(576dot)
8	82.5mm(640dot)

- a=5: Sets printing density to the level specified by (nL+nH×256).

(nL+nH×256)	Printing Density
65530	70%
65531	75%
65532	80%
65533	85%
65534	90%
65535	95%
0(Default)	100%
1	105%
2	110%
3	115%
4	120%
5	125%
6	130%
7	135%
8	140%

- a=6: Sets printing speed to the value specified by (nL+nH×256).

(nL+nH×256)	Printing Speed
1	Printing speed level 1 (84%)
2	Printing speed level 2 (86%)
3	Printing speed level 3 (88%)
4	Printing speed level 4 (90%)
5	Printing speed level 5 (92%)
6	Printing speed level 6 (94%)
7	Printing speed level 7 (96%)
8	Printing speed level 8 (98%)
9(Default)	Printing speed level 9 (100%)

**CT-S2000**

- a=116: Sets the paper specified by (nL+nH×256).

(nL+nH×256)	Paper
1(Default)	Specified single color paper.
257	Recommended 2-color paper5

- a=201: Outputs ACK to the position specified by (nL+nH×256).

(nL+nH×256)	ACK Output Position
1(Default)	ACK-in-Busy
2	ACK-while-Busy
3	ACK-after-Busy

- a=202: Controls input buffer full Busy with the value selected by (nL+nH×256) and controls Busy with output/cancel timing (remaining capacity).

(nL+nH×256)	When Input Buffer Capacity "Small" is Set		When Input Buffer Capacity 4K Bytes (Large) is Set	
	Output	Cancel	Output	Cancel
1	16	26	128	256
2	16	40	128	512
3	30	50	72	256
4	30	60	72	512

- XON/XOFF is also output by the establishment of conditions.
- Ignores the data received when input buffer idle capacity is 0.

- a=212: Selects DMA (Direct Memory Access) control of serial communication specified by (nL+nH×256).

(nL+nH×256)	DMA control
1	Invalid
2(Default)	Valid

- a=213: Selects the flow control specified by (nL+nH×256) when virtual COM is set.

(nL+nH×256)	Flow control
1(Default)	PC setting
2	DTR/DSR
3	XON/XOFF

- a=214: Select the enable/disable of Kanji specified by (nL+nH×256)

(nL+nH×256)	Kanji
1	Invalid(OFF)
2(Default)	Valid(ON)

- a=220: Sets the maximum width of black mark by the amount selected by (nL+nH×256).

$$1 \leq (nL+nH \times 256) \leq 32767$$

Unit: 1 dot

Initial value: 40 dots

## CT-S2000

- a=221: Sets the maximum length of black mark page with the value selected by  $(nL+nH \times 256)$ .

$$1 \leq (nL+nH \times 256) \leq 32767$$

Unit: 1 dot

Initial value: 2360 dots

- a=222: Head margin set by the value selected by  $(nL+nH \times 256)$ .

$$1 \leq (nL+nH \times 256) \leq 32767$$

Unit: 168dot

Initial value: 0dot

- a=223: Sets black mark bottom margin with the amount selected by  $(nL+nH \times 256)$ .

$$1 \leq (nL+nH \times 256) \leq 255$$

Unit: 1 dot

Initial value: 34 dots

- a=224: Sets cut distance with the value selected by  $(nL+nH \times 256)$ .

$$1 \leq (nL+nH \times 256) \leq 255$$

Unit: 1 dot

Initial value: 232 dots

- a=225: Sets head distance with the value selected by  $(nL+nH \times 256)$ .

$$1 \leq (nL+nH \times 256) \leq 255$$

Unit: 1 dot

Initial value: 56 dots

**CT-S4000**

- a=1: Sets the user NV memory capacity to the size specified by (nL+nH×256).

(nL+nH×256)	Memory Capacity
1	1K bytes
2	64K bytes
3	128K bytes
4	192K bytes

- a=2: Sets NV graphic memory capacity to the size specified by (nL+nH×256).

(nL+nH×256)	Memory Capacity
1	None
2	64K bytes
3	128K bytes
4	192K bytes
5	256K bytes
6	320K bytes
7(Default)	384K bytes

- a=3: Sets paper width to the size specified by (nL+nH×256).

(nL+nH×256)	Paper Width
1	360 dots(512 dots for receipt/BM)
4	432 dots(512 dots for receipt/BM)
6	512 dots
7	576 dots
9	660 dots(576 dots for label)
10	720 dots
11(Default)	832 dots

- a=5: Sets printing density to the level specified by (nL+nH×256).

(nL+nH×256)	Printing Density
65530	70%
65531	75%
65532	80%
65533	85%
65534	90%
65535	95%
0(Default)	100%
1	105%
2	110%
3	115%
4	120%
5	125%
6	130%
7	135%
8	140%

- a=6: Sets printing speed to the value specified by (nL+nH×256).

(nL+nH×256)	Printing Speed
1	Printing speed level 1 (84%)
2	Printing speed level 2 (86%)
3	Printing speed level 3 (88%)
4	Printing speed level 4 (90%)
5	Printing speed level 5 (92%)
6	Printing speed level 6 (94%)
7	Printing speed level 7 (96%)
8	Printing speed level 8 (98%)
9(Default)	Printing speed level 9 (100%)

**CT-S4000**

- a=116: Sets the paper specified by (nL+nH×256).

(nL+nH×256)	Paper
1 (Default)	Specified single color paper.
257	Recommended 2-color paper5

- a=201: Outputs ACK to the position specified by (nL+nH×256).

(nL+nH×256)	ACK Output Position
1(Default)	ACK-in-Busy
2	ACK-while-Busy
3	ACK-after-Busy

- a=202: Controls input buffer full Busy with the value selected by (nL+nH×256) and controls Busy with output/cancel timing (remaining capacity).

(nL+nH×256)	When Input Buffer Capacity "Small" is Set		When Input Buffer Capacity 4K Bytes (Large) is Set	
	Output	Cancel	Output	Cancel
1	16	26	128	256
2	16	40	128	512
3	30	50	72	256
4	30	60	72	512

- XON/XOFF is also output by the establishment of conditions.
- Ignores the data received when input buffer idle capacity is 0.

- a=212: Selects DMA (Direct Memory Access) control of serial communication specified by (nL+nH×256).

(nL+nH×256)	DMA control
1	Invalid
2(Default)	Valid

- a=213: Selects the flow control specified by (nL+nH×256) when virtual COM is set.

(nL+nH×256)	Flow control
1(Default)	PC setting
2	DTR/DSR
3	XON/XOFF

- a=214: Select the enable/disable of Kanji specified by (nL+nH×256).

(nL+nH×256)	Kanji
1	Invalid(OFF)
2(Default)	Valid(ON)

## CT-S801/CT-S851

- a=1: Sets the user NV memory capacity to the size specified by (nL+nH×256).

(nL+nH×256)	Memory Capacity
1	1K bytes
2	64K bytes
3	128K bytes
4(Default)	192K bytes

- a=2: Sets NV graphic memory capacity to the size specified by (nL+nH×256).

(nL+nH×256)	Memory Capacity
1	None
2	64K bytes
3	128K bytes
4	192K bytes
5	256K bytes
6	320K bytes
7(Default)	384K bytes

- a=3: Sets paper width to the size specified by (nL+nH×256).

(nL+nH×256)	Paper Width
1	58mm(360dot)
2	58mm(384dot)
3	58mm(420dot)
4	58mm(432dot)
5	58mm(436dot)
6	80mm(512dot)
7(Default)	80mm(576dot)
8	82.5mm(640dot)
9	58mm(390dot)
10	80mm(546dot)

- a=5: Sets printing density to the level specified by (nL+nH×256).

(nL+nH×256)	Printing Density
65530	70%
65531	75%
65532	80%
65533	85%
65534	90%
65535	95%
0(Default)	100%
1	105%
2	110%
3	115%
4	120%
5	125%
6	130%
7	135%
8	140%

- a=6: Sets printing speed to the value specified by (nL+nH×256).

(nL+nH×256)	Printing Speed
1	Printing speed level 1 (84%)
2	Printing speed level 2 (86%)
3	Printing speed level 3 (88%)
4	Printing speed level 4 (90%)
5	Printing speed level 5 (92%)
6	Printing speed level 6 (94%)
7	Printing speed level 7 (96%)
8	Printing speed level 8 (98%)
9(Default)	Printing speed level 9 (100%)

## CT-S801/CT-S851

- a=116: Sets the paper specified by (nL+nH×256).

(nL+nH×256)	Paper
1(Default)	Specified single color paper.
257	Recommended 2-color paper5

- a=201: Outputs ACK to the position specified by (nL+nH×256).

(nL+nH×256)	ACK Output Position
1(Default)	ACK-in-Busy
2	ACK-while-Busy
3	ACK-after-Busy

- a=202: Controls input buffer full Busy with the value selected by (nL+nH×256) and controls Busy with output/cancel timing (remaining capacity).

(nL+nH×256)	When Input Buffer Capacity "Small" is Set		When Input Buffer Capacity 4K Bytes (Large) is Set	
	Output	Cancel	Output	Cancel
1	16	26	128	256
2	16	40	128	512
3	30	50	72	256
4	30	60	72	512

- XON/XOFF is also output by the establishment of conditions.
- Ignores the data received when input buffer idle capacity is 0.

- a=212: Selects DMA (Direct Memory Access) control of serial communication specified by (nL+nH×256).

(nL+nH×256)	DMA control
1	Invalid
2(Default)	Valid

- a=213: Selects the flow control specified by (nL+nH×256) when virtual COM is set.

(nL+nH×256)	Flow control
1(Default)	PC setting
2	DTR/DSR
3	XON/XOFF

- a=214: Select the enable/disable of Kanji specified by (nL+nH×256)

(nL+nH×256)	Kanji
1	Invalid(OFF)
2(Default)	Valid(ON)

- a=216: Select the JIS/Shift JIS specified by (nL+nH×256)

(nL+nH×256)	JIS/Shift JIS
1(Default)	JIS (ON)
2	Shift JIS(OFF)



**CT-S801/CT-S851**

- a=217: Select the international character set specified by (nL+nH×256)

(nL+nH×256)	Int'l Char set	(nL+nH×256)	Int'l Char set
1(Default)	U.S.A.	9	Japan
2	France	10	Norway
3	Germany	11	Denmark II
4	U.K.	12	Spain II
5	Denmark I	13	Latin America
6	Sweden	14	Korea
7	Italy	15	Croatia
8	Spain I	16	P.R. China

- a=218: Select the codepage specified by (nL+nH×256)

(nL+nH×256)	Codepage	(nL+nH×256)	Codepage
1	Codepage PC437	8	Codepage PC866
2	Katakana	9	Codepage PC857
3	Codepage PC850	10	WPC1252
4	Codepage PC860	11	Space page
5	Codepage PC863	12	Codepage PC864
6	Codepage PC865	13	Thai code18
7	Codepage PC852		

- a=220: Sets the maximum width of black mark by the amount selected by (nL+nH×256).

$1 \leq (nL+nH \times 256) \leq 32767$   
 Unit: 1 dot  
 Initial value: 40 dots

- a=221: Sets the maximum length of black mark page with the value selected by (nL+nH×256).

$1 \leq (nL+nH \times 256) \leq 32767$   
 Unit: 1 dot  
 Initial value: 2360 dots

- a=222: Head margin set by the value selected by (nL+nH×256).

$1 \leq (nL+nH \times 256) \leq 32767$   
 Unit: 168dot  
 Initial value: 0dot

- a=223: Sets black mark bottom margin with the amount selected by (nL+nH×256).

$1 \leq (nL+nH \times 256) \leq 255$   
 Unit: 1 dot  
 Initial value: 34 dots

- a=224: Sets cut distance with the value selected by (nL+nH×256).

$1 \leq (nL+nH \times 256) \leq 255$   
 Unit: 1 dot  
 Initial value: 232 dots

**CT-S801/CT-S851**

- a=225: Sets head distance with the value selected by (nL+nH×256).

1≤(nL+nH×256)≤255  
 Unit: 1 dot  
 Initial value: 56 dots

- a=230: Sets the language of LCD messages selected by (nL+nH×256).

(nL+nH×256)	Language
1(Default)	English
2	French
3	German
4	Italian
5	Spanish
6	Japanese
7	Chinese

- a=231: Selects the enable/disable of download LCD message specified by (nL+nH×256)

(nL+nH×256)	Download LCD message
1(Default)	Invalid(ON)
2	Valid(OFF)

- a=232: Sets the LCD auto off time specified by (nL+nH×256)

(nL+nH×256)	LCD auto off time
1(Default)	Invalid
2	30 sec. later
3	5 min. later

- a=233: Selects the enable/disable of key lock specified by (nL+nH×256)

(nL+nH×256)	Key lock
1(Default)	Invalid
2	Valid

- a=234: Selects the direction of LCD message specified by (nL+nH×256)

(nL+nH×256)	LCD display direction
1(Default)	Normal
2	Inverted

- a=240: Sets the buzzer level specified by (nL+nH×256)

(nL+nH×256)	Buzzer volume
1(Default)	Level 1
2	Level 2
3	Level 3
4	Level 4

- a=241: Sets the max number of 1 head division specified by (nL+nH×256)

(nL+nH×256)	Max dot in 1 head division
1	128 dots
2(Default)	200 dots
3	288 dots

### CT-S801/CT-S851

- a=242: Sets the max dot number with Powered USB specified by (nL+nH×256)

<b>(nL+nH×256)</b>	<b>Powered USB max dot nos</b>
1(Default)	128 dots
2	200 dots
3	288 dots

- a=243: Selects the mechanism type specified by (nL+nH×256)

<b>(nL+nH×256)</b>	<b>Mechanism type</b>
1(Default)	2 inch
2	3 inch

**CT-S601/CT-S651**

- a=1: Sets the user NV memory capacity to the size specified by (nL+nH×256).

(nL+nH×256)	Memory Capacity
1	1K bytes
2	64K bytes
3	128K bytes
4(Default)	192K bytes

- a=2: Sets NV graphic memory capacity to the size specified by (nL+nH×256).

(nL+nH×256)	Memory Capacity
1	None
2	64K bytes
3	128K bytes
4	192K bytes
5	256K bytes
6	320K bytes
7(Default)	384K bytes

- a=3: Sets paper width to the size specified by (nL+nH×256).

(nL+nH×256)	Paper Width
1	58mm(360dot)
2	58mm(384dot)
3	58mm(420dot)
4	58mm(432dot)
5	58mm(436dot)
6	80mm(512dot)
7(Default)	80mm(576dot)
8	82.5mm(640dot)
9	58mm(390dot)
10	80mm(546dot)

- a=5: Sets printing density to the level specified by (nL+nH×256).

(nL+nH×256)	Printing Density
65530	70%
65531	75%
65532	80%
65533	85%
65534	90%
65535	95%
0(Default)	100%
1	105%
2	110%
3	115%
4	120%
5	125%
6	130%
7	135%
8	140%

- a=6: Sets printing speed to the value specified by (nL+nH×256).

(nL+nH×256)	Printing Speed
1	Printing speed level 1 (84%)
2	Printing speed level 2 (86%)
3	Printing speed level 3 (88%)
4	Printing speed level 4 (90%)
5	Printing speed level 5 (92%)
6	Printing speed level 6 (94%)
7	Printing speed level 7 (96%)
8	Printing speed level 8 (98%)
9(Default)	Printing speed level 9 (100%)

## CT-S601/CT-S651

- a=116: Sets the paper specified by (nL+nH×256).

(nL+nH×256)	Paper
1(Default)	Specified single color paper.
257	Recommended 2-color paper5

- a=201: Outputs ACK to the position specified by (nL+nH×256).

(nL+nH×256)	ACK Output Position
1(Default)	ACK-in-Busy
2	ACK-while-Busy
3	ACK-after-Busy

- a=202: Controls input buffer full Busy with the value selected by (nL+nH×256) and controls Busy with output/cancel timing (remaining capacity).

(nL+nH×256)	When Input Buffer Capacity "Small" is Set		When Input Buffer Capacity 4K Bytes (Large) is Set	
	Output	Cancel	Output	Cancel
1	16	26	128	256
2	16	40	128	512
3	30	50	72	256
4	30	60	72	512

- XON/XOFF is also output by the establishment of conditions.
- Ignores the data received when input buffer idle capacity is 0.

- a=212: Selects DMA (Direct Memory Access) control of serial communication specified by (nL+nH×256).

(nL+nH×256)	DMA control
1	Invalid
2(Default)	Valid

- a=213: Selects the flow control specified by (nL+nH×256) when virtual COM is set.

(nL+nH×256)	Flow control
1(Default)	PC setting
2	DTR/DSR
3	XON/XOFF

- a=214: Select the enable/disable of Kanji specified by (nL+nH×256)

(nL+nH×256)	Kanji
1	Invalid(OFF)
2(Default)	Valid(ON)

- a=216: Select the JIS/Shift JIS specified by (nL+nH×256)

(nL+nH×256)	JIS/Shift JIS
1(Default)	JIS (ON)
2	Shift JIS(OFF)

**CT-S601/CT-S651**

- a=217: Select the international character set specified by (nL+nH×256)

(nL+nH×256)	Int'l Char set	(nL+nH×256)	Int'l Char set
1(Default)	U.S.A.	9	Japan
2	France	10	Norway
3	Germany	11	Denmark II
4	U.K.	12	Spain II
5	Denmark I	13	Latin America
6	Sweden	14	Korea
7	Italy	15	Croatia
8	Spain I	16	P.R. China

- a=218: Select the codepage specified by (nL+nH×256)

(nL+nH×256)	Codepage	(nL+nH×256)	Codepage
1	Codepage PC437	8	Codepage PC866
2	Katakana	9	Codepage PC857
3	Codepage PC850	10	WPC1252
4	Codepage PC860	11	Space page
5	Codepage PC863	12	Codepage PC864
6	Codepage PC865	13	Thai code18
7	Codepage PC852		

- a=220: Sets the maximum width of black mark by the amount selected by (nL+nH×256).

$1 \leq (nL+nH \times 256) \leq 32767$   
 Unit: 1 dot  
 Initial value: 40 dots

- a=221: Sets the maximum length of black mark page with the value selected by (nL+nH×256).

$1 \leq (nL+nH \times 256) \leq 32767$   
 Unit: 1 dot  
 Initial value: 2360 dots

- a=222: Head margin set by the value selected by (nL+nH×256).

$1 \leq (nL+nH \times 256) \leq 32767$   
 Unit: 168dot  
 Initial value: 0dot

- a=223: Sets black mark bottom margin with the amount selected by (nL+nH×256).

$1 \leq (nL+nH \times 256) \leq 255$   
 Unit: 1 dot  
 Initial value: 34 dots

- a=224: Sets cut distance with the value selected by (nL+nH×256).

$1 \leq (nL+nH \times 256) \leq 255$   
 Unit: 1 dot  
 Initial value: 232 dots

**CT-S601/CT-S651**

- a=225: Sets head distance with the value selected by (nL+nH×256).

$$1 \leq (nL+nH \times 256) \leq 255$$

Unit: 1 dot

Initial value: 56 dots

- a=243: Selects the mechanism type specified by (nL+nH×256)

(nL+nH×256)	Mechanism type
1(Default)	2 inch
2	3 inch

- a=240: Sets the buzzer level specified by (nL+nH×256)

(nL+nH×256)	Buzzer volume
1(Default)	Level 1
2	Level 2
3	Level 3
4	Level 4

- a=241: Sets the max number of 1 head division specified by (nL+nH×256)

(nL+nH×256)	Max dot in 1 head division
1	128 dots
2(Default)	200 dots
3	288 dots

- a=242: Sets the max dot number with Powered USB specified by (nL+nH×256)

(nL+nH×256)	Powered USB max dot nos
1(Default)	128 dots
2	200 dots
3	288 dots

**BD2-2220**

- a=5: Sets printing density to the level specified by (nL+nH×256).

(nL+nH×256)	Printing Density
65530	70%
65531	75%
65532	80%
65533	85%
65534	90%
65535	95%
0(Default)	100%
1	105%
2	110%
3	115%
4	120%
5	125%
6	130%
7	135%
8	140%

- a=6: Sets printing speed to the value specified by (nL+nH×256).

(nL+nH×256)	Printing Speed
1	Printing speed level 1 (84%)
2	Printing speed level 2 (86%)
3	Printing speed level 3 (88%)
4	Printing speed level 4 (90%)
5	Printing speed level 5 (92%)
6	Printing speed level 6 (94%)
7	Printing speed level 7 (96%)
8	Printing speed level 8 (98%)
9(Default)	Printing speed level 9 (100%)

- a=201: Outputs ACK to the position specified by (nL+nH×256).

(nL+nH×256)	ACK Output Position
1(Default)	ACK-in-Busy
2	ACK-while-Busy
3	ACK-after-Busy

- a=202: Controls input buffer full Busy with the value selected by (nL+nH×256) and controls Busy with output/cancel timing (remaining capacity).

(nL+nH×256)	When Input Buffer Capacity "Small" is Set		When Input Buffer Capacity 4K Bytes (Large) is Set	
	Output	Cancel	Output	Cancel
1 (Default)	16	26	128	256
2	16	40	128	512
3	30	50	72	256
4	30	60	72	512

- XON/XOFF is also output by the establishment of conditions.
- Ignores the data received when input buffer idle capacity is 0.



**PMU2XXX**

- a=5: Sets printing density to the level specified by (nL+nH×256).

(nL+nH×256)	Printing Density
65530	70%
65531	75%
65532	80%
65533	85%
65534	90%
65535	95%
0(Default)	100%
1	105%
2	110%
3	115%
4	120%
5	125%
6	130%
7	135%
8	140%

- a=6: Sets printing speed to the value specified by (nL+nH×256).

(nL+nH×256)	Printing Speed
1	Printing speed level 1 (84%)
2	Printing speed level 2 (86%)
3	Printing speed level 3 (88%)
4	Printing speed level 4 (90%)
5	Printing speed level 5 (92%)
6	Printing speed level 6 (94%)
7	Printing speed level 7 (96%)
8	Printing speed level 8 (98%)
9(Default)	Printing speed level 9 (100%)

- a=201: Outputs ACK to the position specified by (nL+nH×256).

(nL+nH×256)	ACK Output Position
1(Default)	ACK-in-Busy
2	ACK-while-Busy
3	ACK-after-Busy

- a=202: Controls input buffer full Busy with the value selected by (nL+nH×256) and controls Busy with output/cancel timing (remaining capacity).

(nL+nH×256)	When Input Buffer Capacity "Small" is Set		When Input Buffer Capacity 4K Bytes (Large) is Set	
	Output	Cancel	Output	Cancel
1(Default)	16	26	128	256
2	16	40	128	512
3	30	50	72	256
4	30	60	72	512

- XON/XOFF is also output by the establishment of conditions.
- Ignores the data received when input buffer idle capacity is 0.
- a=220: Sets the maximum width of black mark by the amount selected by (nL+nH×256).

$$1 \leq (nL+nH \times 256) \leq 32767$$

Unit: 1 dot

Initial value: 40 dots

## PMU2XXX

- a=221: Sets the maximum length of black mark page with the value selected by  $(nL+nH \times 256)$ .

$$1 \leq (nL+nH \times 256) \leq 32767$$

Unit: 1 dot

Initial value: 2360 dots

- a=222: Head margin set by the value selected by  $(nL+nH \times 256)$ .

$$1 \leq (nL+nH \times 256) \leq 32767$$

Unit: 168dot

Initial value: 0dot

- a=223: Sets black mark bottom margin with the amount selected by  $(nL+nH \times 256)$ .

$$1 \leq (nL+nH \times 256) \leq 255$$

Unit: 1 dot

Initial value: 34 dots

- a=224: Sets cut distance with the value selected by  $(nL+nH \times 256)$ .

$$1 \leq (nL+nH \times 256) \leq 255$$

Unit: 1 dot

Initial value: 232 dots

- a=225: Sets head distance with the value selected by  $(nL+nH \times 256)$

$$1 \leq (nL+nH \times 256) \leq 255$$

Unit: 1 dot

Initial value: 56 dots

**PMU2XXXII**

- a=5: Sets printing density to the level specified by (nL+nH×256).

(nL+nH×256)	Printing Density
65530	70%
65531	75%
65532	80%
65533	85%
65534	90%
65535	95%
0(Default)	100%
1	105%
2	110%
3	115%
4	120%
5	125%
6	130%
7	135%
8	140%

- a=6: Sets printing speed to the value specified by (nL+nH×256).

(nL+nH×256)	Printing Speed
1	Printing speed level 1 (84%)
2	Printing speed level 2 (86%)
3	Printing speed level 3 (88%)
4	Printing speed level 4 (90%)
5	Printing speed level 5 (92%)
6	Printing speed level 6 (94%)
7	Printing speed level 7 (96%)
8	Printing speed level 8 (98%)
9 (Default)	Printing speed level 9 (100%)

- a=202: Controls input buffer full Busy with the value selected by (nL+nH×256) and controls Busy with output/cancel timing (remaining capacity).

(nL+nH×256)	When Input Buffer Capacity "Small" is Set		When Input Buffer Capacity 4K Bytes (Large) is Set	
	Output	Cancel	Output	Cancel
1(Default)	16	26	128	256
2	16	40	128	512
3	30	50	72	256
4	30	60	72	512

- XON/XOFF is also output by the establishment of conditions.
- Ignores the data received when input buffer idle capacity is 0.

## PMU2XXXII

- a=220: Sets the maximum width of black mark by the amount selected by (nL+nHx256).

$$1 \leq (nL+nH \times 256) \leq 32767$$

Unit: 1 dot

Initial value: 40 dots

- a=221: Sets the maximum length of black mark page with the value selected by (nL+nHx256).

$$1 \leq (nL+nH \times 256) \leq 32767$$

Unit: 1 dot

Initial value: 2360 dots

- a=222: Head margin set by the value selected by (nL+nHx256).

$$1 \leq (nL+nH \times 256) \leq 32767$$

Unit: 168dot

Initial value: 0dot

- a=223: Sets black mark bottom margin with the amount selected by (nL+nHx256).

$$1 \leq (nL+nH \times 256) \leq 255$$

Unit: 1 dot

Initial value: 34 dots

- a=224: Sets cut distance with the value selected by (nL+nHx256).

$$1 \leq (nL+nH \times 256) \leq 255$$

Unit: 1 dot

Initial value: 232 dots

- a=225: Sets head distance with the value selected by (nL+nHx256).

$$1 \leq (nL+nH \times 256) \leq 255$$

Unit: 1 dot

Initial value: 56 dots

**PMU2300III**

- a=5: Sets printing density to the level specified by (nL+nH×256).

(nL+nH×256)	Printing Density
65530	70%
65531	75%
65532	80%
65533	85%
65534	90%
65535	95%
0(Default)	100%
1	105%
2	110%
3	115%
4	120%
5	125%
6	130%
7	135%
8	140%

- a=6: Sets printing speed to the value specified by (nL+nH×256).

(nL+nH×256)	Printing Speed
1	Printing speed level 1 (84%)
2	Printing speed level 2 (86%)
3	Printing speed level 3 (88%)
4	Printing speed level 4 (90%)
5	Printing speed level 5 (92%)
6	Printing speed level 6 (94%)
7	Printing speed level 7 (96%)
8	Printing speed level 8 (98%)
9 (Default)	Printing speed level 9 (100%)

- a=130: Sets the auto retraction time length selected by (nL+nH×256).  
If n = 0, time length is not set. (Retraction is done by GS R 0 command.)

$1 \leq (nL+nH \times 256) \leq 32767$   
Unit: 100ms  
Initial value: 50 (5000ms)

- a=131: Sets the time length of bezel LED ON at waiting selected by (nL+nH×256).

$1 \leq (nL+nH \times 256) \leq 32767$   
Unit: 100ms  
Initial value: 0 (LED is kept on)

- a=132: Sets the time length of bezel LED ON at blinking selected by (nL+nH×256).

$2 \leq (nL+nH \times 256) \leq 3000$   
Unit: 100ms  
Initial value: 5 (500ms)

- a=133: Sets the time length of bezel LED OFF at blinking selected by (nL+nH×256).

$2 \leq (nL+nH \times 256) \leq 3000$   
Unit: 100ms  
Initial value: 5 (500ms)

## PMU2300III

- a=134: Sets the state of bezel LED at waiting selected by (nL+nH×256).

(nL+nH×256)	Bezel LED state at waiting
0(Default)	Off
1	On
2	Blinking

- a=135: Sets the state of bezel LED at printing selected by (nL+nH×256).

(nL+nH×256)	Bezel LED state at printing
0	Off
1(Default)	On
2	Blinking

- a=136: Sets the state of bezel LED at ejecting selected by (nL+nH×256).

(nL+nH×256)	Bezel LED state at ejecting
0	Off
1	On
2(Default)	Blinking

- a=202: Controls input buffer full Busy with the value selected by (nL+nH×256) and controls Busy with output/cancel timing (remaining capacity).

(nL+nH×256)	When Input Buffer Capacity "Small" is Set		When Input Buffer Capacity 4K Bytes (Large) is Set	
	Output	Cancel	Output	Cancel
1(Default)	16	26	128	256
2	16	40	128	512
3	30	50	72	256
4	30	60	72	512

- XON/XOFF is also output by the establishment of conditions.
- Ignores the data received when input buffer idle capacity is 0.
- a=213: Selects the flow control specified by (nL+nH×256) when virtual COM is set.

(nL+nH×256)	Flow control
1(Default)	PC setting
2	DTR/DSR
3	XON/XOFF

**PMU2300III**

- a=214: Select the enable/disable of Kanji specified by (nL+nH×256)

(nL+nH×256)	Kanji
1	Invalid(OFF)
2(Default)	Valid(ON)

- a=216: Select the JIS/Shift JIS specified by (nL+nH×256)

(nL+nH×256)	JIS/Shift JIS
1(Default)	JIS (ON)
2	Shift JIS(OFF)

- a=217: Select the international character set specified by (nL+nH×256)

(nL+nH×256)	Int'l Char set	(nL+nH×256)	Int'l Char set
1(Default)	U.S.A.	9	Japan
2	France	10	Norway
3	Germany	11	Denmark II
4	U.K.	12	Spain II
5	Denmark I	13	Latin America
6	Sweden	14	Korea
7	Italy	15	Croatia
8	Spain I	16	P.R. China

- a=218: Select the codepage specified by (nL+nH×256)

(nL+nH×256)	Codepage	(nL+nH×256)	Codepage
1(Default)	Codepage PC437	8	Codepage PC866
2	Katakana	9	Codepage PC857
3	Codepage PC850	10	WPC1252
4	Codepage PC860	11	Space page
5	Codepage PC863	12	Codepage PC864
6	Codepage PC865	13	Thai code18
7	Codepage PC852		

### PMU2300III

- a=220: Sets the maximum width of black mark by the amount selected by  $(nL+nH \times 256)$ .

$$1 \leq (nL+nH \times 256) \leq 32767$$

Unit: 1 dot

Initial value: 40 dots

- a=221: Sets the maximum length of black mark page with the value selected by  $(nL+nH \times 256)$ .

$$1 \leq (nL+nH \times 256) \leq 32767$$

Unit: 1 dot

Initial value: 1992 dots

- a=222: Head margin set by the value selected by  $(nL+nH \times 256)$ .

$$1 \leq (nL+nH \times 256) \leq 32767$$

Unit: 226dot

Initial value: 0dot

- a=223: Sets black mark bottom margin with the amount selected by  $(nL+nH \times 256)$ .

$$1 \leq (nL+nH \times 256) \leq 32767$$

Unit: 1 dot

Initial value: 34 dots

- a=224: Sets cut distance with the value selected by  $(nL+nH \times 256)$ .

$$1 \leq (nL+nH \times 256) \leq 32767$$

Unit: 1 dot

Initial value: 316 dots

- a=225: Sets head distance with the value selected by  $(nL+nH \times 256)$ .

$$1 \leq (nL+nH \times 256) \leq 32767$$

Unit: 1 dot

Initial value: 86 dots



## CT-P29x series

- a=5: Sets printing density to the level specified by (nL+nH×256).

(nL+nH×256)	Printing Density
65530	70%
65531	75%
65532	80%
65533	85%
65534	90%
65535	95%
0(Default)	100%
1	105%
2	110%
3	115%
4	120%
5	125%
6	130%
7	135%
8	140%

- a=6: Sets printing speed to the value specified by (nL+nH×256).

(nL+nH×256)	Printing Speed
1	Printing speed level 1 (84%)
2	Printing speed level 2 (86%)
3	Printing speed level 3 (88%)
4	Printing speed level 4 (90%)
5	Printing speed level 5 (92%)
6	Printing speed level 6 (94%)
7	Printing speed level 7 (96%)
8	Printing speed level 8 (98%)
9 (Default)	Printing speed level 9 (100%)

- a=213: Selects the flow control specified by (nL+nH×256) when virtual COM is set.

(nL+nH×256)	Flow control
1(Default)	PC setting
2	DTR/DSR
3	XON/XOFF

- a=214: Select the enable/disable of Kanji specified by (nL+nH×256)

(nL+nH×256)	Kanji
1	Invalid(OFF)
2(Default)	Valid(ON)

- a=216: Select the JIS/Shift JIS specified by (nL+nH×256)

(nL+nH×256)	JIS/Shift JIS
1(Default)	JIS (ON)
2	Shift JIS(OFF)

- a=217: Select the international character set specified by (nL+nH×256)

(nL+nH×256)	Int'l Char set	(nL+nH×256)	Int'l Char set
1(Default)	U.S.A.	9	Japan
2	France	10	Norway
3	Germany	11	Denmark II
4	U.K.	12	Spain II
5	Denmark I	13	Latin America
6	Sweden	14	Korea
7	Italy	15	Croatia
8	Spain I	16	P.R. China

### CT-P29x series

- a=218: Select the codepage specified by (nL+nH×256)

(nL+nH×256)	Codepage	(nL+nH×256)	Codepage
1	Codepage PC437	8	Codepage PC866
2	Katakana	9	Codepage PC857
3	Codepage PC850	10	WPC1252
4	Codepage PC860	11	Space page
5	Codepage PC863	12	Codepage PC864
6	Codepage PC865	13	Thai code18
7	Codepage PC852		

## fn=6: Function 6 Sending the Set Customized Value

# GS ( E pL pH fn a

<b>[Code]</b>	<1D>H<28>H<45>H<pL><pH><fn><a>
<b>[Range]</b>	<p><math>(pL+pH \times 256) = 2</math> (pL=2, pH=0) fn=6</p> <p><b>CT-S280</b> a=5, 6, 116, 201, 202, 214, 216, 217, 218</p> <p><b>CT-S281</b> a=5, 6, 116, 202, 213, 214, 216, 217, 218, 226</p> <p><b>CT-S300/ CT-S310</b> a=3, 5, 6, 97, 116, 201, 202, 220, 221, 222, 223, 224, 225</p> <p><b>CT-S2000</b> a=1, 2, 3, 5, 6, 116, 201, 202, 212, 213, 214, 220, 221, 222, 223, 224, 225</p> <p><b>CT-S4000</b> a=1, 2, 3, 5, 6, 116, 201, 202, 212, 213, 214</p> <p><b>CT-S310II</b> a=1, 2, 3, 5, 6, 202, 212, 213, 214, 216, 217, 218, 244, 245, 246, 247, 248</p> <p><b>CT-S801</b> a=1, 2, 3, 5, 6, 116, 201, 202, 212, 213, 214, 216, 217, 218, 220, 221, 222, 223, 224, 225, 230, 231, 232, 233, 234, 240, 241, 242, 243</p> <p><b>CT-S601</b> a=1, 2, 3, 5, 6, 116, 201, 202, 212, 213, 214, 216, 217, 218, 220, 221, 222, 223, 224, 225, 240, 241, 242, 243</p> <p><b>BD2-2220</b> a=5, 6, 201, 202</p> <p><b>PMU2XXX/PMU2XXXII</b> a=5, 6, 201, 202, 220, 221, 222, 223, 224, 225 *a=220, 221, 222, 223, 224, 225 are supported with only label/BM model.</p> <p><b>PMU2300III</b> a=5, 6, 130, 131, 132, 133, 134, 135, 136, 202, 213, 214, 216, 217, 218, 220, 221, 222, 223, 224, 225 *a=220, 221, 222, 223, 224, 225 are supported with only BM model.</p> <p><b>CT-P29x series</b> a=5, 6, 213, 214, 216, 217, 218</p>

**[Outline] [The specification which is common to the model]**

- Sends the set value of customized value set by "a".

	Hex.	No. of Data
Header	37H	1
ID	27H	1
Customized value No.	30H to 39H	1 to 3
Separation number	1FH	1
Customized value	30H to 39H	1 to 5
NULL	00H	1

• Configuration of customized value No.

a	Sending Data		
	1st Byte	2nd Byte	3rd Byte
1	49(^1')	-	-
2	50(^2')	-	-
3	51(^3')	-	-
5	53(^5')	-	-
6	54(^6')	-	-
97	57(^9')	55(^7')	-
130	49(^1')	51(^3')	48(^0')
131	49(^1')	51(^3')	49(^1')
132	49(^1')	51(^3')	50(^2')
133	49(^1')	51(^3')	51(^3')
134	49(^1')	51(^3')	52(^4')
135	49(^1')	51(^3')	53(^5')
136	49(^1')	51(^3')	54(^6')
116	49(^1')	49(^1')	54(^6')
201	50(^2')	48(^0')	49(^1')
202	50(^2')	48(^0')	50(^2')
212	50(^2')	49(^1')	50(^2')
213	50(^2')	49(^1')	51(^3')
214	50(^2')	49(^1')	52(^4')
216	50(^2')	49(^1')	54(^6')
217	50(^2')	49(^1')	55(^7')
218	50(^2')	49(^1')	56(^8')
220	50(^2')	50(^2')	48(^0')
221	50(^2')	50(^2')	49(^1')
222	50(^2')	50(^2')	50(^2')
223	50(^2')	50(^2')	51(^3')
224	50(^2')	50(^2')	52(^4')
225	50(^2')	50(^2')	53(^5')
226	50(^2')	50(^2')	54(^6')
230	50(^2')	51(^3')	48(^0')
231	50(^2')	51(^3')	49(^1')
232	50(^2')	51(^3')	50(^2')
233	50(^2')	51(^3')	51(^3')
234	50(^2')	51(^3')	52(^4')
240	50(^2')	52(^4')	48(^0')
241	50(^2')	52(^4')	49(^1')
242	50(^2')	52(^4')	50(^2')
243	50(^2')	52(^4')	51(^3')

## CT-S280

- a=5: When print density is specified

Setting Status		Sending Data				
Stored Value	Print Density	1st Byte	2nd Byte	3rd Byte	4th Byte	5th Byte
65530	70%	54("6")	53("5")	53("5")	51("3")	48("0")
65531	75%	54("6")	53("5")	53("5")	51("3")	49("1")
65532	80%	54("6")	53("5")	53("5")	51("3")	50("2")
65533	85%	54("6")	53("5")	53("5")	51("3")	51("3")
65534	90%	54("6")	53("5")	53("5")	51("3")	52("4")
65535	95%	54("6")	53("5")	53("5")	51("3")	53("5")
0	Basic density	48("0")	-	-	-	-
1	105%	49("1")	-	-	-	-
2	110%	50("2")	-	-	-	-
3	115%	51("3")	-	-	-	-
4	120%	52("4")	-	-	-	-
5	125%	53("5")	-	-	-	-
6	130%	54("6")	-	-	-	-
7	135%	55("7")	-	-	-	-
8	140%	56("8")	-	-	-	-

- a=6: When printing speed is specified

Setting Status		Sending Data				
Stored Value	Print Speed	1st Byte	2nd Byte	3rd Byte	4th Byte	5th Byte
1	Speed level 1	49("1")	-	-	-	-
2	Speed level 2	50("2")	-	-	-	-
3	Speed level 3	51("3")	-	-	-	-
4	Speed level 4	52("4")	-	-	-	-
5	Speed level 5	53("5")	-	-	-	-
6	Speed level 6	54("6")	-	-	-	-
7	Speed level 7	55("7")	-	-	-	-
8	Speed level 8	56("8")	-	-	-	-
9	Speed level 9	57("9")	-	-	-	-

- a=116: When kind of paper is specified

Setting Status		Sending Data				
Stored Value	Paper	1st Byte	2nd Byte	3rd Byte	4th Byte	5th Byte
1	Single-color paper	49("1")	-	-	-	-
2	2-color paper	50("2")	-	-	-	-

- a=201: When ACK output position is specified

Setting Status		Sending Data				
Stored Value	ACK Output Position	1st Byte	2nd Byte	3rd Byte	4th Byte	5th Byte
1	ACK-in-Busy	49("1")	-	-	-	-
2	ACK-while-Busy	50("2")	-	-	-	-
3	ACK-after-Busy	51("3")	-	-	-	-

- a=202: Input buffer full Busy output/cancel timing

Setting Status		Sending Data				
Stored Value	BUSY Output/Cancel	1st Byte	2nd Byte	3rd Byte	4th Byte	5th Byte
1		49("1")	-	-	-	-
2		50("2")	-	-	-	-
3		51("3")	-	-	-	-
4		52("4")	-	-	-	-

- a=214: When Kanji is specified

Setting Status		Sending Data				
Stored Value	Kanji	1st Byte	2nd Byte	3rd Byte	4th Byte	5th Byte
1	OFF	49("1")	-	-	-	-
2	ON	50("2")	-	-	-	-

**CT-S280**

- a=216: When JIS/Shift JIS is specified

Setting Status		Sending Data				
Stored Value	JIS/Shift JIS	1 <sup>st</sup> Byte	2 <sup>nd</sup> Byte	3 <sup>rd</sup> Byte	4 <sup>th</sup> Byte	5 <sup>th</sup> Byte
1	JIS	49("\1")	-	-	-	-
2	Shift JIS	50("\2")	-	-	-	-

- a=217: When international character set is specified

Setting Status		Sending Data				
Stored Value	Int'l char. set	1 <sup>st</sup> Byte	2 <sup>nd</sup> Byte	3 <sup>rd</sup> Byte	4 <sup>th</sup> Byte	5 <sup>th</sup> Byte
1	U.S.A.	49("\1")	-	-	-	-
2	France	50("\2")	-	-	-	-
3	Germany	51("\3")	-	-	-	-
4	U.K.	52("\4")	-	-	-	-
5	Denmark I	53("\5")	-	-	-	-
6	Sweden	54("\6")	-	-	-	-
7	Italy	55("\7")	-	-	-	-
8	Spain I	56("\8")	-	-	-	-
9	Japan	57("\9")	-	-	-	-
10	Norway	49("\1")	48("\0")	-	-	-
11	Denmark II	49("\1")	49("\1")	-	-	-
12	Spain II	49("\1")	50("\2")	-	-	-
13	Latin America	49("\1")	51("\3")	-	-	-
14	Korea	49("\1")	52("\4")	-	-	-

- a=218: When codepage is specified

Setting Status		Sending Data				
Stored Value	Codepage	1 <sup>st</sup> Byte	2 <sup>nd</sup> Byte	3 <sup>rd</sup> Byte	4 <sup>th</sup> Byte	5 <sup>th</sup> Byte
1	Codepage PC437	49("\1")	-	-	-	-
2	Katakana	50("\2")	-	-	-	-
3	Codepage PC850	51("\3")	-	-	-	-
4	Codepage PC860	52("\4")	-	-	-	-
5	Codepage PC863	53("\5")	-	-	-	-
6	Codepage PC865	54("\6")	-	-	-	-
7	Codepage PC852	55("\7")	-	-	-	-
8	Codepage PC866	56("\8")	-	-	-	-
9	Codepage PC857	57("\9")	-	-	-	-
10	WPC1252	49("\1")	48("\0")	-	-	-
11	Space page	49("\1")	49("\1")	-	-	-
12	Codepage PC864	49("\1")	50("\2")	-	-	-
13	Thaicode18	49("\1")	51("\3")	-	-	-

## CT-S281

- a=5: When print density is specified

Setting Status		Sending Data				
Stored Value	Print Density	1st Byte	2nd Byte	3rd Byte	4th Byte	5th Byte
65530	70%	54("6")	53("5")	53("5")	51("3")	48("0")
65531	75%	54("6")	53("5")	53("5")	51("3")	49("1")
65532	80%	54("6")	53("5")	53("5")	51("3")	50("2")
65533	85%	54("6")	53("5")	53("5")	51("3")	51("3")
65534	90%	54("6")	53("5")	53("5")	51("3")	52("4")
65535	95%	54("6")	53("5")	53("5")	51("3")	53("5")
0	Basic density	48("0")	-	-	-	-
1	105%	49("1")	-	-	-	-
2	110%	50("2")	-	-	-	-
3	115%	51("3")	-	-	-	-
4	120%	52("4")	-	-	-	-
5	125%	53("5")	-	-	-	-
6	130%	54("6")	-	-	-	-
7	135%	55("7")	-	-	-	-
8	140%	56("8")	-	-	-	-

- a=6: When printing speed is specified

Setting Status		Sending Data				
Stored Value	Print Density	1st Byte	2nd Byte	3rd Byte	4th Byte	5th Byte
1	Speed level 1	49("1")	-	-	-	-
2	Speed level 2	50("2")	-	-	-	-
3	Speed level 3	51("3")	-	-	-	-
4	Speed level 4	52("4")	-	-	-	-
5	Speed level 5	53("5")	-	-	-	-
6	Speed level 6	54("6")	-	-	-	-
7	Speed level 7	55("7")	-	-	-	-
8	Speed level 8	56("8")	-	-	-	-
9	Speed level 9	57("9")	-	-	-	-

- a=116: When kind of paper is specified

Setting Status		Sending Data				
Stored Value	Paper	1st Byte	2nd Byte	3rd Byte	4th Byte	5th Byte
1	Single-color paper	49("1")	-	-	-	-
2	2-color paper	50("2")	53("5")	50("7")	-	-

- a=202: Input buffer full Busy output/cancel timing

Setting Status		Sending Data				
Stored Value	BUSY Output/Cancel	1st Byte	2nd Byte	3rd Byte	4th Byte	5th Byte
1		49("1")	-	-	-	-
2		50("2")	-	-	-	-
3		51("3")	-	-	-	-
4		52("4")	-	-	-	-

- a=213: When the flow control of virtual COM is specified.

Setting Status		Sending Data				
Stored Value	Flow control	1st Byte	2nd Byte	3rd Byte	4th Byte	5th Byte
1	PC setting	49("1")	-	-	-	-
2	DTR/DSR	50("2")	-	-	-	-
3	XON/XOF	51("3")	-	-	-	-

- a=214: When Kanji is specified

Setting Status		Sending Data				
Stored Value	Kanji	1st Byte	2nd Byte	3rd Byte	4th Byte	5th Byte
1	OFF	49("1")	-	-	-	-
2	ON	50("2")	-	-	-	-

## CT-S281

- a=216: When JIS/Shift JIS is specified

Setting Status		Sending Data				
Stored Value	JIS/Shift JIS	1st Byte	2nd Byte	3rd Byte	4th Byte	5th Byte
1	JIS	49("1")	-	-	-	-
2	Shift JIS	50("2")	-	-	-	-

- a=217: When international character set is specified

Setting Status		Sending Data				
Stored Value	Int'l char. set	1st Byte	2nd Byte	3rd Byte	4th Byte	5th Byte
1	U.S.A.	49("1")	-	-	-	-
2	France	50("2")	-	-	-	-
3	Germany	51("3")	-	-	-	-
4	U.K.	52("4")	-	-	-	-
5	Denmark I	53("5")	-	-	-	-
6	Sweden	54("6")	-	-	-	-
7	Italy	55("7")	-	-	-	-
8	Spain I	56("8")	-	-	-	-
9	Japan	57("9")	-	-	-	-
10	Norway	49("1")	48("0")	-	-	-
11	Denmark II	49("1")	49("1")	-	-	-
12	Spain II	49("1")	50("2")	-	-	-
13	Latin America	49("1")	51("3")	-	-	-
14	Korea	49("1")	52("4")	-	-	-
15	Croatia	49("1")	53("5")	-	-	-
16	P.R.China	49("1")	54("6")	-	-	-

- a=218: When codepage is specified

Setting Status		Sending Data				
Stored Value	Codepage	1st Byte	2nd Byte	3rd Byte	4th Byte	5th Byte
1	Codepage PC437	49("1")	-	-	-	-
2	Katakana	50("2")	-	-	-	-
3	Codepage PC850	51("3")	-	-	-	-
4	Codepage PC860	52("4")	-	-	-	-
5	Codepage PC863	53("5")	-	-	-	-
6	Codepage PC865	54("6")	-	-	-	-
7	Codepage PC852	55("7")	-	-	-	-
8	Codepage PC866	56("8")	-	-	-	-
9	Codepage PC857	57("9")	-	-	-	-
10	WPC1252	49("1")	48("0")	-	-	-
11	Space page	49("1")	49("1")	-	-	-
12	Codepage PC864	49("1")	50("2")	-	-	-
13	Thaicode18	49("1")	51("3")	-	-	-

- a=226: When the wait time for manual cut is specified.

Setting Status		Sending Data				
Stored Value	Wait time for manual cut	1st Byte	2nd Byte	3rd Byte	4th Byte	5th Byte
0	0 sec	48("0")	48("0")	48("0")	48("0")	48("0")
1	1 sec	48("0")	48("0")	48("0")	48("0")	49("1")
⋮	⋮	⋮	⋮	⋮	⋮	⋮
1200	1200 sec	48("0")	49("1")	50("2")	48("0")	48("0")



## CT-S300/CT-S310

- a=3: When paper width is specified

Setting Status		Sending Data				
Stored Value	Paper Width	1st Byte	2nd Byte	3rd Byte	4th Byte	5th Byte
1	58mm	49("1")	-	-	-	-
6	80mm	54("6")	-	-	-	-

- a=5: When print density is specified

Setting Status		Sending Data				
Stored Value	Print Density	1st Byte	2nd Byte	3rd Byte	4th Byte	5th Byte
65530	70%	54("6")	53("5")	53("5")	51("3")	48("0")
65531	75%	54("6")	53("5")	53("5")	51("3")	49("1")
65532	80%	54("6")	53("5")	53("5")	51("3")	50("2")
65533	85%	54("6")	53("5")	53("5")	51("3")	51("3")
65534	90%	54("6")	53("5")	53("5")	51("3")	52("4")
65535	95%	54("6")	53("5")	53("5")	51("3")	53("5")
0	Basic density	48("0")	-	-	-	-
1	105%	49("1")	-	-	-	-
2	110%	50("2")	-	-	-	-
3	115%	51("3")	-	-	-	-
4	120%	52("4")	-	-	-	-
5	125%	53("5")	-	-	-	-
6	130%	54("6")	-	-	-	-
7	135%	55("7")	-	-	-	-
8	140%	56("8")	-	-	-	-

- a=6: When printing speed is specified

Setting Status		Sending Data				
Stored Value	Print Speed	1st Byte	2nd Byte	3rd Byte	4th Byte	5th Byte
1	Speed level 1	49("1")	-	-	-	-
2	Speed level 2	50("2")	-	-	-	-
3	Speed level 3	51("3")	-	-	-	-
4	Speed level 4	52("4")	-	-	-	-
5	Speed level 5	53("5")	-	-	-	-
6	Speed level 6	54("6")	-	-	-	-
7	Speed level 7	55("7")	-	-	-	-
8	Speed level 8	56("8")	-	-	-	-
9	Speed level 9	57("9")	-	-	-	-

- a=97: When number of divisions for head conducting is specified

Setting Status		Sending Data				
Stored Value	No. of Divisions	1st Byte	2nd Byte	3rd Byte	4th Byte	5th Byte
2	2 division conducting	50("2")	-	-	-	-
4	4 division conducting	52("4")	-	-	-	-

- a=116: When kind of paper is specified

Setting Status		Sending Data				
Stored Value	Paper	1st Byte	2nd Byte	3rd Byte	4th Byte	5th Byte
1	Single-color paper	49("1")	-	-	-	-
2	2-color paper	50("2")	53("5")	55("7")	-	-

## CT-S300/CT-S310

- a=201: When ACK output position is specified

Setting Status		Sending Data				
Stored Value	ACK Output Position	1st Byte	2nd Byte	3rd Byte	4th Byte	5th Byte
1	ACK-in-Busy	49("1")	-	-	-	-
2	ACK-while-Busy	50("2")	-	-	-	-
3	ACK-after-Busy	51("3")	-	-	-	-

\* support by CT-S300

- a=202: Input buffer full Busy output/cancel timing

Setting Status		Sending Data				
Stored Value	BUSY Output/Cancel	1st Byte	2nd Byte	3rd Byte	4th Byte	5th Byte
1		49("1")	-	-	-	-
2		50("2")	-	-	-	-
3		51("3")	-	-	-	-
4		52("4")	-	-	-	-

- a=220: When maximum black mark width is specified

Setting Status		Sending Data				
Stored Value	Maximum B.M Width	1st Byte	2nd Byte	3rd Byte	4th Byte	5th Byte
0	0dot	49("1")	48("0")	48("0")	48("0")	48("0")
⋮	⋮	⋮	⋮	⋮	⋮	⋮
32767	32767dot	51("3")	50("2")	55("7")	54("6")	55("7")

- a=221: When maximum length of black mark page is specified

Setting Status		Sending Data				
Stored Value	Maximum B.M Page Length	1st Byte	2nd Byte	3rd Byte	4th Byte	5th Byte
0	0dot	49("1")	48("0")	48("0")	48("0")	48("0")
⋮	⋮	⋮	⋮	⋮	⋮	⋮
32767	32767dot	51("3")	50("2")	55("7")	54("6")	55("7")

- a=222: When head margin is specified

Setting Status		Sending Data				
Stored Value	Head Margin	1st Byte	2nd Byte	3rd Byte	4th Byte	5th Byte
0	0dot	49("1")	48("0")	48("0")	48("0")	48("0")
⋮	⋮	⋮	⋮	⋮	⋮	⋮
32767	32767dot	51("3")	50("2")	55("7")	54("6")	55("7")

- a=223: When bottom margin is specified

Setting Status		Sending Data				
Stored Value	Bottom Margin	1st Byte	2nd Byte	3rd Byte	4th Byte	5th Byte
0	0	48("0")	48("0")	48("0")	-	-
⋮	⋮	⋮	⋮	⋮	⋮	⋮
255	255	50("2")	53("5")	53("5")	-	-

- a=224: When cut distance is specified

Setting Status		Sending Data				
Stored Value	Cut Distance	1st Byte	2nd Byte	3rd Byte	4th Byte	5th Byte
0	0	48("0")	48("0")	48("0")	-	-
⋮	⋮	⋮	⋮	⋮	⋮	⋮
255	255	50("2")	53("5")	53("5")	-	-

- a=225: When head distance is specified

Setting Status		Sending Data				
Stored Value	Head Distance	1st Byte	2nd Byte	3rd Byte	4th Byte	5th Byte
0	0	48("0")	48("0")	48("0")	-	-
⋮	⋮	⋮	⋮	⋮	⋮	⋮
255	255	50("2")	53("5")	53("5")	-	-

## CT-S310II

- a=1: When user NV memory capacity is specified

Setting Status		Sending Data				
Stored Value	Memory Capacity	1st Byte	2nd Byte	3rd Byte	4th Byte	5th Byte
1	1K bytes	49("1")	-	-	-	-
2	64K bytes	50("2")	-	-	-	-
3	128K bytes	51("3")	-	-	-	-
4	192K bytes	52("4")	-	-	-	-

- a=2: When NV graphics memory capacity is specified

Setting Status		Sending Data				
Stored Value	Memory Capacity	1st Byte	2nd Byte	3rd Byte	4th Byte	5th Byte
1	None	49("1")	-	-	-	-
2	64K bytes	50("2")	-	-	-	-
3	128K bytes	51("3")	-	-	-	-
4	192K bytes	52("4")	-	-	-	-
5	256K bytes	53("5")	-	-	-	-
6	320K bytes	54("6")	-	-	-	-
7	384K bytes	55("7")	-	-	-	-

- a=3: When paper width is specified

Setting Status		Sending Data				
Stored Value	Paper Width	1st Byte	2nd Byte	3rd Byte	4th Byte	5th Byte
1	58mm(360dot)	49("1")	-	-	-	-
2	58mm(384dot)	50("2")	-	-	-	-
3	58mm(420dot)	51("3")	-	-	-	-
4	58mm(432dot)	52("4")	-	-	-	-
5	58mm(436dot)	53("5")	-	-	-	-
6	80mm(512dot)	54("6")	-	-	-	-
7	80mm(576dot)	55("7")	-	-	-	-
8	82.5mm(640dot)	56("8")	-	-	-	-
9	58mm(390dot)	57("9")	-	-	-	-
10	80mm(546dot)	49("1")	48("0")	-	-	-

- a=5: When print density is specified

Setting Status		Sending Data				
Stored Value	Print Density	1st Byte	2nd Byte	3rd Byte	4th Byte	5th Byte
65530	70%	54("6")	53("5")	53("5")	51("3")	48("0")
65531	75%	54("6")	53("5")	53("5")	51("3")	49("1")
65532	80%	54("6")	53("5")	53("5")	51("3")	50("2")
65533	85%	54("6")	53("5")	53("5")	51("3")	51("3")
65534	90%	54("6")	53("5")	53("5")	51("3")	52("4")
65535	95%	54("6")	53("5")	53("5")	51("3")	53("5")
0	Basic density	48("0")	-	-	-	-
1	105%	49("1")	-	-	-	-
2	110%	50("2")	-	-	-	-
3	115%	51("3")	-	-	-	-
4	120%	52("4")	-	-	-	-
5	125%	53("5")	-	-	-	-
6	130%	54("6")	-	-	-	-
7	135%	55("7")	-	-	-	-
8	140%	56("8")	-	-	-	-

- a=6: When printing speed is specified

Setting Status		Sending Data				
Stored Value	Print Speed	1st Byte	2nd Byte	3rd Byte	4th Byte	5th Byte
1	Speed level 1	49("1")	-	-	-	-
2	Speed level 2	50("2")	-	-	-	-
3	Speed level 3	51("3")	-	-	-	-
4	Speed level 4	52("4")	-	-	-	-
5	Speed level 5	53("5")	-	-	-	-
6	Speed level 6	54("6")	-	-	-	-
7	Speed level 7	55("7")	-	-	-	-
8	Speed level 8	56("8")	-	-	-	-
9	Speed level 9	57("9")	-	-	-	-

## CT-S310II

- a=202: Input buffer full Busy output/cancel timing

Setting Status		Sending Data				
Stored Value	BUSY Output/Cancel	1st Byte	2nd Byte	3rd Byte	4th Byte	5th Byte
1		49("1")	-	-	-	-
2		50("2")	-	-	-	-
3		51("3")	-	-	-	-
4		52("4")	-	-	-	-

- a=212: When DMA (Direct Memory Access) control of serial communication is specified

Setting Status		Sending Data				
Stored Value	DMA control	1st Byte	2nd Byte	3rd Byte	4th Byte	5th Byte
1	Valid	49("1")	-	-	-	-
2	Invalid	50("2")	-	-	-	-

- a=213: When the flow control of virtual COM is specified.

Setting Status		Sending Data				
Stored Value	Flow control	1st Byte	2nd Byte	3rd Byte	4th Byte	5th Byte
1	PC setting	49("1")	-	-	-	-
2	DTR/DSR	50("2")	-	-	-	-
3	XON/XOF	51("3")	-	-	-	-

- a=214: When Kanji is specified

Setting Status		Sending Data				
Stored Value	Kanji	1st Byte	2nd Byte	3rd Byte	4th Byte	5th Byte
1	OFF	49("1")	-	-	-	-
2	ON	50("2")	-	-	-	-

- a=216: When JIS/Shift JIS is specified

Setting Status		Sending Data				
Stored Value	JIS/Shift JIS	1st Byte	2nd Byte	3rd Byte	4th Byte	5th Byte
1	JIS	49("1")	-	-	-	-
2	Shift JIS (CP932)	50("2")	-	-	-	-
3	Shift JIS (X0213)	51("3")	-	-	-	-

- a=217: When international character set is specified

Setting Status		Sending Data				
Stored Value	Int'l char. set	1st Byte	2nd Byte	3rd Byte	4th Byte	5th Byte
1	U.S.A.	49("1")	-	-	-	-
2	France	50("2")	-	-	-	-
3	Germany	51("3")	-	-	-	-
4	U.K.	52("4")	-	-	-	-
5	Denmark I	53("5")	-	-	-	-
6	Sweden	54("6")	-	-	-	-
7	Italy	55("7")	-	-	-	-
8	Spain I	56("8")	-	-	-	-
9	Japan	57("9")	-	-	-	-
10	Norway	49("1")	48("0")	-	-	-
11	Denmark II	49("1")	49("1")	-	-	-
12	Spain II	49("1")	50("2")	-	-	-
13	Latin America	49("1")	51("3")	-	-	-
14	Korea	49("1")	52("4")	-	-	-
15	Croatia	49("1")	53("5")	-	-	-
16	P.R.China	49("1")	54("6")	-	-	-

## CT-S310II

- a=218: When codepage is specified

Setting Status		Sending Data				
Stored Value	Codepage	1st Byte	2nd Byte	3rd Byte	4th Byte	5th Byte
1	Codepage PC437	49("1")	-	-	-	-
2	Katakana	50("2")	-	-	-	-
3	Codepage PC850	51("3")	-	-	-	-
4	Codepage PC860	52("4")	-	-	-	-
5	Codepage PC863	53("5")	-	-	-	-
6	Codepage PC865	54("6")	-	-	-	-
7	Codepage PC852	55("7")	-	-	-	-
8	Codepage PC866	56("8")	-	-	-	-
9	Codepage PC857	57("9")	-	-	-	-
10	WPC1252	49("1")	48("0")	-	-	-
11	Space page	49("1")	49("1")	-	-	-
12	Codepage PC864	49("1")	50("2")	-	-	-
13	Thaicode18	49("1")	51("3")	-	-	-

- a=244: When Top Margin is specified

Setting Status		Sending Data				
Stored Value	Codepage	1st Byte	2nd Byte	3rd Byte	4th Byte	5th Byte
1	11mm	49("1")	—	—	—	—
2	3mm	50("2")	—	—	—	—
3	4mm	51("3")	—	—	—	—
4	5mm	52("4")	—	—	—	—
5	6mm	53("5")	—	—	—	—
6	7mm	54("6")	—	—	—	—
7	8mm	55("7")	—	—	—	—
8	9mm	56("8")	—	—	—	—
9	10mm	57("9")	—	—	—	—

- a=245: When Line Gap Reduce n is specified

Setting Status		Sending Data				
Stored Value	Line Gap Reduce	1st Byte	2nd Byte	3rd Byte	4th Byte	5th Byte
1	Invalid	49("1")	—	—	—	—
2	3/4	50("2")	—	—	—	—
3	2/3	51("3")	—	—	—	—
4	1/2	52("4")	—	—	—	—
5	1/3	53("5")	—	—	—	—
6	1/4	54("6")	—	—	—	—
7	1/5	55("7")	—	—	—	—
8	All	56("8")	—	—	—	—

- a=246: When Reduced Char V/H is specified

Setting Status		Sending Data				
Stored Value	Reduced Char V/H	1st Byte	2nd Byte	3rd Byte	4th Byte	5th Byte
1	100% / 100%	49("1")	—	—	—	—
2	75% / 100%	50("2")	—	—	—	—
3	50% / 100%	51("3")	—	—	—	—
4	100% / 75%	52("4")	—	—	—	—
5	75% / 75%	53("5")	—	—	—	—
6	50% / 75%	54("6")	—	—	—	—

## CT-S310II

·a=247: When Auto Side Shift is specified

Setting Status		Sending Data				
Stored Value	Auto Side Shift	1st Byte	2nd Byte	3rd Byte	4th Byte	5th Byte
1	Invalid	49("1")	—	—	—	—
2	1dot	50("2")	—	—	—	—
3	2dot	51("3")	—	—	—	—
4	3dot	52("4")	—	—	—	—
5	4dot	53("5")	—	—	—	—
6	5dot	54("6")	—	—	—	—
7	6dot	55("7")	—	—	—	—
8	7dot	56("8")	—	—	—	—

·a=248: When Buzzer Event is specified

Setting Status		Sending Data				
Stored Value	Buzzer Event	1st Byte	2nd Byte	3rd Byte	4th Byte	5th Byte
1	All Event/Error	49("1")	—	—	—	—
2	Not by C.Open	50("2")	—	—	—	—
3	Not by C.Open/PE	51("3")	—	—	—	—

## CT-S2000

- a=1: When user NV memory capacity is specified

Setting Status		Sending Data				
Stored Value	Memory Capacity	1st Byte	2nd Byte	3rd Byte	4th Byte	5th Byte
1	1K bytes	49("1")	-	-	-	-
2	64K bytes	50("2")	-	-	-	-
3	128K bytes	51("3")	-	-	-	-
4	192K bytes	52("4")	-	-	-	-

- a=2: When NV graphics memory capacity is specified

Setting Status		Sending Data				
Stored Value	Memory Capacity	1st Byte	2nd Byte	3rd Byte	4th Byte	5th Byte
1	None	49("1")	-	-	-	-
2	64K bytes	50("2")	-	-	-	-
3	128K bytes	51("3")	-	-	-	-
4	192K bytes	52("4")	-	-	-	-
5	256K bytes	53("5")	-	-	-	-
6	320K bytes	54("6")	-	-	-	-
7	384K bytes	55("7")	-	-	-	-

- a=3: When paper width is specified

Setting Status		Sending Data				
Stored Value	Paper Width	1st Byte	2nd Byte	3rd Byte	4th Byte	5th Byte
1	58mm(360dot)	49("1")	-	-	-	-
2	58mm(384dot)	50("2")	-	-	-	-
3	58mm(420dot)	51("3")	-	-	-	-
4	58mm(432dot)	52("4")	-	-	-	-
5	58mm(436dot)	53("5")	-	-	-	-
6	80mm(512dot)	54("6")	-	-	-	-
7	80mm(576dot)	55("7")	-	-	-	-
8	82.5mm(640dot)	56("8")	-	-	-	-

- a=5: When print density is specified

Setting Status		Sending Data				
Stored Value	Print Density	1st Byte	2nd Byte	3rd Byte	4th Byte	5th Byte
65530	70%	54("6")	53("5")	53("5")	51("3")	48("0")
65531	75%	54("6")	53("5")	53("5")	51("3")	49("1")
65532	80%	54("6")	53("5")	53("5")	51("3")	50("2")
65533	85%	54("6")	53("5")	53("5")	51("3")	51("3")
65534	90%	54("6")	53("5")	53("5")	51("3")	52("4")
65535	95%	54("6")	53("5")	53("5")	51("3")	53("5")
0	Basic density	48("0")	-	-	-	-
1	105%	49("1")	-	-	-	-
2	110%	50("2")	-	-	-	-
3	115%	51("3")	-	-	-	-
4	120%	52("4")	-	-	-	-
5	125%	53("5")	-	-	-	-
6	130%	54("6")	-	-	-	-
7	135%	55("7")	-	-	-	-
8	140%	56("8")	-	-	-	-

- a=6: When printing speed is specified

Setting Status		Sending Data				
Stored Value	Print Speed	1st Byte	2nd Byte	3rd Byte	4th Byte	5th Byte
1	Speed level 1	49("1")	-	-	-	-
2	Speed level 2	50("2")	-	-	-	-
3	Speed level 3	51("3")	-	-	-	-
4	Speed level 4	52("4")	-	-	-	-
5	Speed level 5	53("5")	-	-	-	-
6	Speed level 6	54("6")	-	-	-	-
7	Speed level 7	55("7")	-	-	-	-
8	Speed level 8	56("8")	-	-	-	-
9	Speed level 9	57("9")	-	-	-	-

## CT-S2000

- a=116: When kind of paper is specified

Setting Status		Sending Data				
Stored Value	Paper	1st Byte	2nd Byte	3rd Byte	4th Byte	5th Byte
1	Single-color paper	49("1")	-	-	-	-
2	2-color paper	50("2")	53("5")	55("7")	-	-

- a=201: When ACK output position is specified

Setting Status		Sending Data				
Stored Value	ACK Output Position	1st Byte	2nd Byte	3rd Byte	4th Byte	5th Byte
1	ACK-in-Busy	49("1")	-	-	-	-
2	ACK-while-Busy	50("2")	-	-	-	-
3	ACK-after-Busy	51("3")	-	-	-	-

- a=202: Input buffer full Busy output/cancel timing

Setting Status		Sending Data				
Stored Value	BUSY Output/Cancel	1st Byte	2nd Byte	3rd Byte	4th Byte	5th Byte
1		49("1")	-	-	-	-
2		50("2")	-	-	-	-
3		51("3")	-	-	-	-
4		52("4")	-	-	-	-

- a=212: When DMA (Direct Memory Access) control of serial communication is specified

Setting Status		Sending Data				
Stored Value	DMA control	1st Byte	2nd Byte	3rd Byte	4th Byte	5th Byte
1	Valid	49("1")	-	-	-	-
2	Invalid	50("2")	-	-	-	-

- a=213: When the flow control of virtual COM is specified.

Setting Status		Sending Data				
Stored Value	Flow control	1st Byte	2nd Byte	3rd Byte	4th Byte	5th Byte
1	PC setting	49("1")	-	-	-	-
2	DTR/DSR	50("2")	-	-	-	-
3	XON/XOF	51("3")	-	-	-	-

- a=214: When Kanji is specified

Setting Status		Sending Data				
Stored Value	Kanji	1st Byte	2nd Byte	3rd Byte	4th Byte	5th Byte
1	OFF	49("1")	-	-	-	-
2	ON	50("2")	-	-	-	-

- a=220: When maximum black mark width is specified

Setting Status		Sending Data				
Stored Value	Maximum B.M Width	1st Byte	2nd Byte	3rd Byte	4th Byte	5th Byte
0	0dot	49("1")	48("0")	48("0")	48("0")	48("0")
⋮	⋮	⋮	⋮	⋮	⋮	⋮
32767	32767dot	51("3")	50("2")	55("7")	54("6")	55("7")

- a=221: When maximum black mark page length is specified

Setting Status		Sending Data				
Stored Value	Maximum B.M page length	1st Byte	2nd Byte	3rd Byte	4th Byte	5th Byte
0	0dot	49("1")	48("0")	48("0")	48("0")	48("0")
⋮	⋮	⋮	⋮	⋮	⋮	⋮
32767	32767dot	51("3")	50("2")	55("7")	54("6")	55("7")



## CT-S2000

- a=222: When head margin is specified

Setting Status		Sending Data				
Stored Value	Head Margin	1st Byte	2nd Byte	3rd Byte	4th Byte	5th Byte
0	0dot	49(^"1")	48(^"0")	48(^"0")	48(^"0")	48(^"0")
⋮	⋮	⋮	⋮	⋮	⋮	⋮
32767	32767dot	51(^"3")	50(^"2")	55(^"7")	54(^"6")	55(^"7")

- a=223: When bottom margin is specified

Setting Status		Sending Data				
Stored Value	Bottom Margin	1st Byte	2nd Byte	3rd Byte	4th Byte	5th Byte
0	0	48(^"0")	48(^"0")	48(^"0")	-	-
⋮	⋮	⋮	⋮	⋮	⋮	⋮
255	255	50(^"2")	53(^"5")	53(^"5")	-	-

- a=224: When cut distance is specified

Setting Status		Sending Data				
Stored Value	Cut Distance	1st Byte	2nd Byte	3rd Byte	4th Byte	5th Byte
0	0	48(^"0")	48(^"0")	48(^"0")	-	-
⋮	⋮	⋮	⋮	⋮	⋮	⋮
255	255	50(^"2")	53(^"5")	53(^"5")	-	-

- a=225: When head distance is specified

Setting Status		Sending Data				
Stored Value	Head Distance	1st Byte	2nd Byte	3rd Byte	4th Byte	5th Byte
0	0	48(^"0")	48(^"0")	48(^"0")	-	-
⋮	⋮	⋮	⋮	⋮	⋮	⋮
255	255	50(^"2")	53(^"5")	53(^"5")	-	-

**CT-S4000**

- a=1: When user NV memory capacity is specified

Setting Status		Sending Data				
Stored Value	Memory Capacity	1st Byte	2nd Byte	3rd Byte	4th Byte	5th Byte
1	1K bytes	49("1")	-	-	-	-
2	64K bytes	50("2")	-	-	-	-
3	128K bytes	51("3")	-	-	-	-
4	192K bytes	52("4")	-	-	-	-

- a=2: When NV graphics memory capacity is specified

Setting Status		Sending Data				
Stored Value	Memory Capacity	1st Byte	2nd Byte	3rd Byte	4th Byte	5th Byte
1	None	49("1")	-	-	-	-
2	64K bytes	50("2")	-	-	-	-
3	128K bytes	51("3")	-	-	-	-
4	192K bytes	52("4")	-	-	-	-
5	256K bytes	53("5")	-	-	-	-
6	320K bytes	54("6")	-	-	-	-
7	384K bytes	55("7")	-	-	-	-

- a=3: When paper width is specified

Setting Status		Sending Data				
Stored Value	Paper Width	1st Byte	2nd Byte	3rd Byte	4th Byte	5th Byte
1	360 dots	49("1")	-	-	-	-
4	432 dots	52("4")	-	-	-	-
6	512 dots	54("6")	-	-	-	-
7	576 dots	55("7")	-	-	-	-
9	660 dots	57("9")	-	-	-	-
10	720 dots	49("1")	48("0")	-	-	-
11	832 dots	49("1")	49("1")	-	-	-

- a=5: When print density is specified

Setting Status		Sending Data				
Stored Value	Print Density	1st Byte	2nd Byte	3rd Byte	4th Byte	5th Byte
65530	70%	54("6")	53("5")	53("5")	51("3")	48("0")
65531	75%	54("6")	53("5")	53("5")	51("3")	49("1")
65532	80%	54("6")	53("5")	53("5")	51("3")	50("2")
65533	85%	54("6")	53("5")	53("5")	51("3")	51("3")
65534	90%	54("6")	53("5")	53("5")	51("3")	52("4")
65535	95%	54("6")	53("5")	53("5")	51("3")	53("5")
0	Basic density	48("0")	-	-	-	-
1	105%	49("1")	-	-	-	-
2	110%	50("2")	-	-	-	-
3	115%	51("3")	-	-	-	-
4	120%	52("4")	-	-	-	-
5	125%	53("5")	-	-	-	-
6	130%	54("6")	-	-	-	-
7	135%	55("7")	-	-	-	-
8	140%	56("8")	-	-	-	-

- a=6: When printing speed is specified

Setting Status		Sending Data				
Stored Value	Print Speed	1st Byte	2nd Byte	3rd Byte	4th Byte	5th Byte
1	Speed level 1	49("1")	-	-	-	-
2	Speed level 2	50("2")	-	-	-	-
3	Speed level 3	51("3")	-	-	-	-
4	Speed level 4	52("4")	-	-	-	-
5	Speed level 5	53("5")	-	-	-	-
6	Speed level 6	54("6")	-	-	-	-
7	Speed level 7	55("7")	-	-	-	-
8	Speed level 8	56("8")	-	-	-	-
9	Speed level 9	57("9")	-	-	-	-

## CT-S4000

- a=116: When kind of paper is specified

Setting Status		Sending Data				
Stored Value	Paper	1st Byte	2nd Byte	3rd Byte	4th Byte	5th Byte
1	Single-color paper	49("1")	-	-	-	-
2	2-color paper	50("2")	53("5")	55("7")	-	-

- a=201: When ACK output position is specified

Setting Status		Sending Data				
Stored Value	ACK Output Position	1st Byte	2nd Byte	3rd Byte	4th Byte	5th Byte
1	ACK-in-Busy	49("1")	-	-	-	-
2	ACK-while-Busy	50("2")	-	-	-	-
3	ACK-after-Busy	51("3")	-	-	-	-

- a=202: Input buffer full Busy output/cancel timing

Setting Status		Sending Data				
Stored Value	BUSY Output/Cancel	1st Byte	2nd Byte	3rd Byte	4th Byte	5th Byte
1		49("1")	-	-	-	-
2		50("2")	-	-	-	-
3		51("3")	-	-	-	-
4		52("4")	-	-	-	-

- a=212: When DMA (Direct Memory Access) control of serial communication is specified

Setting Status		Sending Data				
Stored Value	DMA control	1st Byte	2nd Byte	3rd Byte	4th Byte	5th Byte
1	Valid	49("1")	-	-	-	-
2	Invalid	50("2")	-	-	-	-

- a=213: When the flow control of virtual COM is specified.

Setting Status		Sending Data				
Stored Value	Flow control	1st Byte	2nd Byte	3rd Byte	4th Byte	5th Byte
1	PC setting	49("1")	-	-	-	-
2	DTR/DSR	50("2")	-	-	-	-
3	XON/XOF	51("3")	-	-	-	-

- a=214: When Kanji is specified

Setting Status		Sending Data				
Stored Value	Kanji	1st Byte	2nd Byte	3rd Byte	4th Byte	5th Byte
1	OFF	49("1")	-	-	-	-
2	ON	50("2")	-	-	-	-

## CT-S801/CT-S851

- a=1: When user NV memory capacity is specified

Setting Status		Sending Data				
Stored Value	Memory Capacity	1st Byte	2nd Byte	3rd Byte	4th Byte	5th Byte
1	1K bytes	49("1")	-	-	-	-
2	64K bytes	50("2")	-	-	-	-
3	128K bytes	51("3")	-	-	-	-
4	192K bytes	52("4")	-	-	-	-

- a=2: When NV graphics memory capacity is specified

Setting Status		Sending Data				
Stored Value	Memory Capacity	1st Byte	2nd Byte	3rd Byte	4th Byte	5th Byte
1	None	49("1")	-	-	-	-
2	64K bytes	50("2")	-	-	-	-
3	128K bytes	51("3")	-	-	-	-
4	192K bytes	52("4")	-	-	-	-
5	256K bytes	53("5")	-	-	-	-
6	320K bytes	54("6")	-	-	-	-
7	384K bytes	55("7")	-	-	-	-

- a=3: When paper width is specified

Setting Status		Sending Data				
Stored Value	Paper Width	1st Byte	2nd Byte	3rd Byte	4th Byte	5th Byte
1	58mm(360dot)	49("1")	-	-	-	-
2	58mm(384dot)	50("2")	-	-	-	-
3	58mm(420dot)	51("3")	-	-	-	-
4	58mm(432dot)	52("4")	-	-	-	-
5	58mm(436dot)	53("5")	-	-	-	-
6	80mm(512dot)	54("6")	-	-	-	-
7	80mm(576dot)	55("7")	-	-	-	-
8	82.5mm(640dot)	56("8")	-	-	-	-
9	58mm(390dot)	57("9")	-	-	-	-
10	80mm(546dot)	49("1")	48("0")	-	-	-

- a=5: When print density is specified

Setting Status		Sending Data				
Stored Value	Print Density	1st Byte	2nd Byte	3rd Byte	4th Byte	5th Byte
65530	70%	54("6")	53("5")	53("5")	51("3")	48("0")
65531	75%	54("6")	53("5")	53("5")	51("3")	49("1")
65532	80%	54("6")	53("5")	53("5")	51("3")	50("2")
65533	85%	54("6")	53("5")	53("5")	51("3")	51("3")
65534	90%	54("6")	53("5")	53("5")	51("3")	52("4")
65535	95%	54("6")	53("5")	53("5")	51("3")	53("5")
0	Basic density	48("0")	-	-	-	-
1	105%	49("1")	-	-	-	-
2	110%	50("2")	-	-	-	-
3	115%	51("3")	-	-	-	-
4	120%	52("4")	-	-	-	-
5	125%	53("5")	-	-	-	-
6	130%	54("6")	-	-	-	-
7	135%	55("7")	-	-	-	-
8	140%	56("8")	-	-	-	-

- a=6: When printing speed is specified

Setting Status		Sending Data				
Stored Value	Print Speed	1st Byte	2nd Byte	3rd Byte	4th Byte	5th Byte
1	Speed level 1	49("1")	-	-	-	-
2	Speed level 2	50("2")	-	-	-	-
3	Speed level 3	51("3")	-	-	-	-
4	Speed level 4	52("4")	-	-	-	-
5	Speed level 5	53("5")	-	-	-	-
6	Speed level 6	54("6")	-	-	-	-
7	Speed level 7	55("7")	-	-	-	-
8	Speed level 8	56("8")	-	-	-	-
9	Speed level 9	57("9")	-	-	-	-

## CT-S801/CT-S851

- a=116: When kind of paper is specified

Setting Status		Sending Data				
Stored Value	Paper	1st Byte	2nd Byte	3rd Byte	4th Byte	5th Byte
1	Single-color paper	49("1")	-	-	-	-
2	2-color paper	50("2")	53("5")	55("7")	-	-

- a=201: When ACK output position is specified

Setting Status		Sending Data				
Stored Value	ACK Output Position	1st Byte	2nd Byte	3rd Byte	4th Byte	5th Byte
1	ACK-in-Busy	49("1")	-	-	-	-
2	ACK-while-Busy	50("2")	-	-	-	-
3	ACK-after-Busy	51("3")	-	-	-	-

- a=202: Input buffer full Busy output/cancel timing

Setting Status		Sending Data				
Stored Value	BUSY Output/Cancel	1st Byte	2nd Byte	3rd Byte	4th Byte	5th Byte
1		49("1")	-	-	-	-
2		50("2")	-	-	-	-
3		51("3")	-	-	-	-
4		52("4")	-	-	-	-

- a=212: When DMA (Direct Memory Access) control of serial communication is specified

Setting Status		Sending Data				
Stored Value	DMA control	1st Byte	2nd Byte	3rd Byte	4th Byte	5th Byte
1	Valid	49("1")	-	-	-	-
2	Invalid	50("2")	-	-	-	-

- a=213: When the flow control of virtual COM is specified.

Setting Status		Sending Data				
Stored Value	Flow control	1st Byte	2nd Byte	3rd Byte	4th Byte	5th Byte
1	PC setting	49("1")	-	-	-	-
2	DTR/DSR	50("2")	-	-	-	-
3	XON/XOF	51("3")	-	-	-	-

- a=214: When Kanji is specified

Setting Status		Sending Data				
Stored Value	Kanji	1st Byte	2nd Byte	3rd Byte	4th Byte	5th Byte
1	OFF	49("1")	-	-	-	-
2	ON	50("2")	-	-	-	-

- a=216: When JIS/Shift JIS is specified

Setting Status		Sending Data				
Stored Value	JIS/Shift JIS	1st Byte	2nd Byte	3rd Byte	4th Byte	5th Byte
1	JIS	49("1")	-	-	-	-
2	Shift JIS	50("2")	-	-	-	-

## CT-S801/CT-S851

- a=217: When international character set is specified

Setting Status		Sending Data				
Stored Value	Int'l char. set	1st Byte	2nd Byte	3rd Byte	4th Byte	5th Byte
1	U.S.A.	49("1")	-	-	-	-
2	France	50("2")	-	-	-	-
3	Germany	51("3")	-	-	-	-
4	U.K.	52("4")	-	-	-	-
5	Denmark I	53("5")	-	-	-	-
6	Sweden	54("6")	-	-	-	-
7	Italy	55("7")	-	-	-	-
8	Spain I	56("8")	-	-	-	-
9	Japan	57("9")	-	-	-	-
10	Norway	49("1")	48("0")	-	-	-
11	Denmark II	49("1")	49("1")	-	-	-
12	Spain II	49("1")	50("2")	-	-	-
13	Latin America	49("1")	51("3")	-	-	-
14	Korea	49("1")	52("4")	-	-	-
15	Croatia	49("1")	53("5")	-	-	-
16	P.R.China	49("1")	54("6")	-	-	-

- a=218: When codepage is specified

Setting Status		Sending Data				
Stored Value	Codepage	1st Byte	2nd Byte	3rd Byte	4th Byte	5th Byte
1	Codepage PC437	49("1")	-	-	-	-
2	Katakana	50("2")	-	-	-	-
3	Codepage PC850	51("3")	-	-	-	-
4	Codepage PC860	52("4")	-	-	-	-
5	Codepage PC863	53("5")	-	-	-	-
6	Codepage PC865	54("6")	-	-	-	-
7	Codepage PC852	55("7")	-	-	-	-
8	Codepage PC866	56("8")	-	-	-	-
9	Codepage PC857	57("9")	-	-	-	-
10	WPC1252	49("1")	48("0")	-	-	-
11	Space page	49("1")	49("1")	-	-	-
12	Codepage PC864	49("1")	50("2")	-	-	-
13	Thaicode18	49("1")	51("3")	-	-	-

- a=220: When maximum black mark width is specified

Setting Status		Sending Data				
Stored Value	Maximum B.M Width	1st Byte	2nd Byte	3rd Byte	4th Byte	5th Byte
0	0dot	49("1")	48("0")	48("0")	48("0")	48("0")
⋮	⋮	⋮	⋮	⋮	⋮	⋮
32767	32767dot	51("3")	50("2")	55("7")	54("6")	55("7")

- a=221: When maximum black mark page length is specified

Setting Status		Sending Data				
Stored Value	Maximum B.M page length	1st Byte	2nd Byte	3rd Byte	4th Byte	5th Byte
0	0dot	49("1")	48("0")	48("0")	48("0")	48("0")
⋮	⋮	⋮	⋮	⋮	⋮	⋮
32767	32767dot	51("3")	50("2")	55("7")	54("6")	55("7")

- a=222: When head margin is specified

Setting Status		Sending Data				
Stored Value	Head Margin	1st Byte	2nd Byte	3rd Byte	4th Byte	5th Byte
0	0dot	49("1")	48("0")	48("0")	48("0")	48("0")
⋮	⋮	⋮	⋮	⋮	⋮	⋮
32767	32767dot	51("3")	50("2")	55("7")	54("6")	55("7")

## CT-S801/CT-S851

- a=223: When bottom margin is specified

Setting Status		Sending Data				
Stored Value	Bottom Margin	1st Byte	2nd Byte	3rd Byte	4th Byte	5th Byte
0	0	48("0")	48("0")	48("0")	-	-
⋮	⋮	⋮	⋮	⋮	⋮	⋮
255	255	50("2")	53("5")	53("5")	-	-

- a=224: When cut distance is specified

Setting Status		Sending Data				
Stored Value	Cut Distance	1st Byte	2nd Byte	3rd Byte	4th Byte	5th Byte
0	0	48("0")	48("0")	48("0")	-	-
⋮	⋮	⋮	⋮	⋮	⋮	⋮
255	255	50("2")	53("5")	53("5")	-	-

- a=225: When head distance is specified

Setting Status		Sending Data				
Stored Value	Head Distance	1st Byte	2nd Byte	3rd Byte	4th Byte	5th Byte
0	0	48("0")	48("0")	48("0")	-	-
⋮	⋮	⋮	⋮	⋮	⋮	⋮
255	255	50("2")	53("5")	53("5")	-	-

- a=230: When LCD language is specified

Setting Status		Sending Data				
Stored Value	LCD language	1st Byte	2nd Byte	3rd Byte	4th Byte	5th Byte
1	English	49("1")	-	-	-	-
2	French	50("2")	-	-	-	-
3	German	51("3")	-	-	-	-
4	Italian	52("4")	-	-	-	-
5	Spanish	53("5")	-	-	-	-
6	Japanese	54("6")	-	-	-	-
7	Chinese	55("7")	-	-	-	-

- a=231: When LCD download characters is specified

Setting Status		Sending Data				
Stored Value	LCD download	1st Byte	2nd Byte	3rd Byte	4th Byte	5th Byte
1	Disabled	49("1")	-	-	-	-
2	Enabled	50("2")	-	-	-	-

- a=232: When LCD auto off time is specified

Setting Status		Sending Data				
Stored Value	Auto off time	1st Byte	2nd Byte	3rd Byte	4th Byte	5th Byte
1	None	49("1")	-	-	-	-
2	30 sec. later	50("2")	-	-	-	-
3	5 min. later	51("3")	-	-	-	-

- a=233: When key lock is specified

Setting Status		Sending Data				
Stored Value	Key lock	1st Byte	2nd Byte	3rd Byte	4th Byte	5th Byte
1	Enabled	49("1")	-	-	-	-
2	Disabled	50("2")	-	-	-	-

## CT-S801/CT-S851

- a=234:When LCD direction is specified

Setting Status		Sending Data				
Stored Value	LCD direction	1st Byte	2nd Byte	3rd Byte	4th Byte	5th Byte
1	Normal	49("1")	-	-	-	-
2	Inverted	50("2")	-	-	-	-

- a=240:When buzzer volume is specified

Setting Status		Sending Data				
Stored Value	Buzzer volume	1st Byte	2nd Byte	3rd Byte	4th Byte	5th Byte
1	Level 1	49("1")	-	-	-	-
2	Level 2	50("2")	-	-	-	-
3	Level 3	51("3")	-	-	-	-
4	Level 4	52("4")	-	-	-	-

- a=241:When max dot number in 1 head division is specified

Setting Status		Sending Data				
Stored Value	Dot number	1st Byte	2nd Byte	3rd Byte	4th Byte	5th Byte
1	128 dots	49("1")	-	-	-	-
2	200 dots	50("2")	-	-	-	-
3	288 dots	51("3")	-	-	-	-

- a=242:When Powered USB max dot number is specified

Setting Status		Sending Data				
Stored Value	Dot number	1st Byte	2nd Byte	3rd Byte	4th Byte	5th Byte
1	128 dots	49("1")	-	-	-	-
2	200 dots	50("2")	-	-	-	-
3	288 dots	51("3")	-	-	-	-

- a=243:When Mechanism type is specified

Setting Status		Sending Data				
Stored Value	Mechanism type	1st Byte	2nd Byte	3rd Byte	4th Byte	5th Byte
1	2 inch	49("1")	-	-	-	-
2	3 inch	50("2")	-	-	-	-



**CT-S601/CT-S651**

- a=1: When user NV memory capacity is specified

Setting Status		Sending Data				
Stored Value	Memory Capacity	1st Byte	2nd Byte	3rd Byte	4th Byte	5th Byte
1	1K bytes	49("1")	-	-	-	-
2	64K bytes	50("2")	-	-	-	-
3	128K bytes	51("3")	-	-	-	-
4	192K bytes	52("4")	-	-	-	-

- a=2: When NV graphics memory capacity is specified

Setting Status		Sending Data				
Stored Value	Memory Capacity	1st Byte	2nd Byte	3rd Byte	4th Byte	5th Byte
1	None	49("1")	-	-	-	-
2	64K bytes	50("2")	-	-	-	-
3	128K bytes	51("3")	-	-	-	-
4	192K bytes	52("4")	-	-	-	-
5	256K bytes	53("5")	-	-	-	-
6	320K bytes	54("6")	-	-	-	-
7	384K bytes	55("7")	-	-	-	-

- a=3: When paper width is specified

Setting Status		Sending Data				
Stored Value	Paper Width	1st Byte	2nd Byte	3rd Byte	4th Byte	5th Byte
1	58mm(360dot)	49("1")	-	-	-	-
2	58mm(384dot)	50("2")	-	-	-	-
3	58mm(420dot)	51("3")	-	-	-	-
4	58mm(432dot)	52("4")	-	-	-	-
5	58mm(436dot)	53("5")	-	-	-	-
6	80mm(512dot)	54("6")	-	-	-	-
7	80mm(576dot)	55("7")	-	-	-	-
8	82.5mm(640dot)	56("8")	-	-	-	-
9	58mm(390dot)	57("9")	-	-	-	-
10	80mm(546dot)	49("1")	48("0")	-	-	-

- a=5: When print density is specified

Setting Status		Sending Data				
Stored Value	Print Density	1st Byte	2nd Byte	3rd Byte	4th Byte	5th Byte
65530	70%	54("6")	53("5")	53("5")	51("3")	48("0")
65531	75%	54("6")	53("5")	53("5")	51("3")	49("1")
65532	80%	54("6")	53("5")	53("5")	51("3")	50("2")
65533	85%	54("6")	53("5")	53("5")	51("3")	51("3")
65534	90%	54("6")	53("5")	53("5")	51("3")	52("4")
65535	95%	54("6")	53("5")	53("5")	51("3")	53("5")
0	Basic density	48("0")	-	-	-	-
1	105%	49("1")	-	-	-	-
2	110%	50("2")	-	-	-	-
3	115%	51("3")	-	-	-	-
4	120%	52("4")	-	-	-	-
5	125%	53("5")	-	-	-	-
6	130%	54("6")	-	-	-	-
7	135%	55("7")	-	-	-	-
8	140%	56("8")	-	-	-	-

- a=6: When printing speed is specified

Setting Status		Sending Data				
Stored Value	Print Speed	1st Byte	2nd Byte	3rd Byte	4th Byte	5th Byte
1	Speed level 1	49("1")	-	-	-	-
2	Speed level 2	50("2")	-	-	-	-
3	Speed level 3	51("3")	-	-	-	-
4	Speed level 4	52("4")	-	-	-	-
5	Speed level 5	53("5")	-	-	-	-
6	Speed level 6	54("6")	-	-	-	-
7	Speed level 7	55("7")	-	-	-	-
8	Speed level 8	56("8")	-	-	-	-
9	Speed level 9	57("9")	-	-	-	-

## CT-S601/CT-S651

- a=116: When kind of paper is specified

Setting Status		Sending Data				
Stored Value	Paper	1st Byte	2nd Byte	3rd Byte	4th Byte	5th Byte
1	Single-color paper	49("1")	-	-	-	-
2	2-color paper	50("2")	53("5")	55("7")	-	-

- a=201: When ACK output position is specified

Setting Status		Sending Data				
Stored Value	ACK Output Position	1st Byte	2nd Byte	3rd Byte	4th Byte	5th Byte
1	ACK-in-Busy	49("1")	-	-	-	-
2	ACK-while-Busy	50("2")	-	-	-	-
3	ACK-after-Busy	51("3")	-	-	-	-

- a=202: Input buffer full Busy output/cancel timing

Setting Status		Sending Data				
Stored Value	BUSY Output/Cancel	1st Byte	2nd Byte	3rd Byte	4th Byte	5th Byte
1		49("1")	-	-	-	-
2		50("2")	-	-	-	-
3		51("3")	-	-	-	-
4		52("4")	-	-	-	-

- a=212: When DMA (Direct Memory Access) control of serial communication is specified

Setting Status		Sending Data				
Stored Value	DMA control	1st Byte	2nd Byte	3rd Byte	4th Byte	5th Byte
1	Valid	49("1")	-	-	-	-
2	Invalid	50("2")	-	-	-	-

- a=213: When the flow control of virtual COM is specified.

Setting Status		Sending Data				
Stored Value	Flow control	1st Byte	2nd Byte	3rd Byte	4th Byte	5th Byte
1	PC setting	49("1")	-	-	-	-
2	DTR/DSR	50("2")	-	-	-	-
3	XON/XOF	51("3")	-	-	-	-

- a=214: When Kanji is specified

Setting Status		Sending Data				
Stored Value	Kanji	1st Byte	2nd Byte	3rd Byte	4th Byte	5th Byte
1	OFF	49("1")	-	-	-	-
2	ON	50("2")	-	-	-	-

- a=216: When JIS/Shift JIS is specified

Setting Status		Sending Data				
Stored Value	JIS/Shift JIS	1st Byte	2nd Byte	3rd Byte	4th Byte	5th Byte
1	JIS	49("1")	-	-	-	-
2	Shift JIS	50("2")	-	-	-	-

## CT-S601/CT-S651

- a=217: When international character set is specified

Setting Status		Sending Data				
Stored Value	Int'l char. set	1st Byte	2nd Byte	3rd Byte	4th Byte	5th Byte
1	U.S.A.	49("1")	-	-	-	-
2	France	50("2")	-	-	-	-
3	Germany	51("3")	-	-	-	-
4	U.K.	52("4")	-	-	-	-
5	Denmark I	53("5")	-	-	-	-
6	Sweden	54("6")	-	-	-	-
7	Italy	55("7")	-	-	-	-
8	Spain I	56("8")	-	-	-	-
9	Japan	57("9")	-	-	-	-
10	Norway	49("1")	48("0")	-	-	-
11	Denmark II	49("1")	49("1")	-	-	-
12	Spain II	49("1")	50("2")	-	-	-
13	Latin America	49("1")	51("3")	-	-	-
14	Korea	49("1")	52("4")	-	-	-
15	Croatia	49("1")	53("5")	-	-	-
16	P.R.China	49("1")	54("6")	-	-	-

- a=218: When codepage is specified

Setting Status		Sending Data				
Stored Value	Codepage	1st Byte	2nd Byte	3rd Byte	4th Byte	5th Byte
1	Codepage PC437	49("1")	-	-	-	-
2	Katakana	50("2")	-	-	-	-
3	Codepage PC850	51("3")	-	-	-	-
4	Codepage PC860	52("4")	-	-	-	-
5	Codepage PC863	53("5")	-	-	-	-
6	Codepage PC865	54("6")	-	-	-	-
7	Codepage PC852	55("7")	-	-	-	-
8	Codepage PC866	56("8")	-	-	-	-
9	Codepage PC857	57("9")	-	-	-	-
10	WPC1252	49("1")	48("0")	-	-	-
11	Space page	49("1")	49("1")	-	-	-
12	Codepage PC864	49("1")	50("2")	-	-	-
13	Thaicode18	49("1")	51("3")	-	-	-

- a=220: When maximum black mark width is specified

Setting Status		Sending Data				
Stored Value	Maximum B.M Width	1st Byte	2nd Byte	3rd Byte	4th Byte	5th Byte
0	0dot	49("1")	48("0")	48("0")	48("0")	48("0")
⋮	⋮	⋮	⋮	⋮	⋮	⋮
32767	32767dot	51("3")	50("2")	55("7")	54("6")	55("7")

- a=221: When maximum black mark page length is specified

Setting Status		Sending Data				
Stored Value	Maximum B.M page length	1st Byte	2nd Byte	3rd Byte	4th Byte	5th Byte
0	0dot	49("1")	48("0")	48("0")	48("0")	48("0")
⋮	⋮	⋮	⋮	⋮	⋮	⋮
32767	32767dot	51("3")	50("2")	55("7")	54("6")	55("7")

- a=222: When head margin is specified

Setting Status		Sending Data				
Stored Value	Head Margin	1st Byte	2nd Byte	3rd Byte	4th Byte	5th Byte
0	0dot	49("1")	48("0")	48("0")	48("0")	48("0")
⋮	⋮	⋮	⋮	⋮	⋮	⋮
32767	32767dot	51("3")	50("2")	55("7")	54("6")	55("7")

### CT-S601/CT-S651

- a=223: When bottom margin is specified

Setting Status		Sending Data				
Stored Value	Bottom Margin	1st Byte	2nd Byte	3rd Byte	4th Byte	5th Byte
0	0	48("0")	48("0")	48("0")	-	-
⋮	⋮	⋮	⋮	⋮	⋮	⋮
255	255	50("2")	53("5")	53("5")	-	-

- a=224: When cut distance is specified

Setting Status		Sending Data				
Stored Value	Cut Distance	1st Byte	2nd Byte	3rd Byte	4th Byte	5th Byte
0	0	48("0")	48("0")	48("0")	-	-
⋮	⋮	⋮	⋮	⋮	⋮	⋮
255	255	50("2")	53("5")	53("5")	-	-

- a=225: When head distance is specified

Setting Status		Sending Data				
Stored Value	Head Distance	1st Byte	2nd Byte	3rd Byte	4th Byte	5th Byte
0	0	48("0")	48("0")	48("0")	-	-
⋮	⋮	⋮	⋮	⋮	⋮	⋮
255	255	50("2")	53("5")	53("5")	-	-

- a=240: When buzzer volume is specified

Setting Status		Sending Data				
Stored Value	Buzzer volume	1st Byte	2nd Byte	3rd Byte	4th Byte	5th Byte
1	Level 1	49("1")	-	-	-	-
2	Level 2	50("2")	-	-	-	-
3	Level 3	51("3")	-	-	-	-
4	Level 4	52("4")	-	-	-	-

- a=241: When max dot number in 1 head division is specified

Setting Status		Sending Data				
Stored Value	Dot number	1st Byte	2nd Byte	3rd Byte	4th Byte	5th Byte
1	128 dots	49("1")	-	-	-	-
2	200 dots	50("2")	-	-	-	-
3	288 dots	51("3")	-	-	-	-

- a=242: When Powered USB max dot number is specified

Setting Status		Sending Data				
Stored Value	Dot number	1st Byte	2nd Byte	3rd Byte	4th Byte	5th Byte
1	128 dots	49("1")	-	-	-	-
2	200 dots	50("2")	-	-	-	-
3	288 dots	51("3")	-	-	-	-

- a=243: When Mechanism type is specified

Setting Status		Sending Data				
Stored Value	Mechanism type	1st Byte	2nd Byte	3rd Byte	4th Byte	5th Byte
1	2 inch	49("1")	-	-	-	-
2	3 inch	50("2")	-	-	-	-

## BD2-2220

- a=5: When print density is specified

Setting Status		Sending Data				
Stored Value	Print Density	1st Byte	2nd Byte	3rd Byte	4th Byte	5th Byte
65530	70%	54("6")	53("5")	53("5")	51("3")	48("0")
65531	75%	54("6")	53("5")	53("5")	51("3")	49("1")
65532	80%	54("6")	53("5")	53("5")	51("3")	50("2")
65533	85%	54("6")	53("5")	53("5")	51("3")	51("3")
65534	90%	54("6")	53("5")	53("5")	51("3")	52("4")
65535	95%	54("6")	53("5")	53("5")	51("3")	53("5")
0	Basic density	48("0")	-	-	-	-
1	105%	49("1")	-	-	-	-
2	110%	50("2")	-	-	-	-
3	115%	51("3")	-	-	-	-
4	120%	52("4")	-	-	-	-
5	125%	53("5")	-	-	-	-
6	130%	54("6")	-	-	-	-
7	135%	55("7")	-	-	-	-
8	140%	56("8")	-	-	-	-

- a=6: When printing speed is specified

Setting Status		Sending Data				
Stored Value	Print Speed	1st Byte	2nd Byte	3rd Byte	4th Byte	5th Byte
1	Speed level 1	49("1")	-	-	-	-
2	Speed level 2	50("2")	-	-	-	-
3	Speed level 3	51("3")	-	-	-	-
4	Speed level 4	52("4")	-	-	-	-
5	Speed level 5	53("5")	-	-	-	-
6	Speed level 6	54("6")	-	-	-	-
7	Speed level 7	55("7")	-	-	-	-
8	Speed level 8	56("8")	-	-	-	-
9	Speed level 9	57("9")	-	-	-	-

- a=201: When ACK output position is specified

Setting Status		Sending Data				
Stored Value	ACK Output Position	1st Byte	2nd Byte	3rd Byte	4th Byte	5th Byte
1	ACK-in-Busy	49("1")	-	-	-	-
2	ACK-while-Busy	50("2")	-	-	-	-
3	ACK-after-Busy	51("3")	-	-	-	-

- a=202: Input buffer full Busy output/cancel timing

Setting Status		Sending Data				
Stored Value	BUSY Output/Cancel	1st Byte	2nd Byte	3rd Byte	4th Byte	5th Byte
1		49("1")	-	-	-	-
2		50("2")	-	-	-	-
3		51("3")	-	-	-	-
4		52("4")	-	-	-	-

## PMU2XXX

- a=5: When print density is specified

Setting Status		Sending Data				
Stored Value	Print Density	1st Byte	2nd Byte	3rd Byte	4th Byte	5th Byte
65530	70%	54(^6")	53(^5")	53(^5")	51(^3")	48(^0")
65531	75%	54(^6")	53(^5")	53(^5")	51(^3")	49(^1")
65532	80%	54(^6")	53(^5")	53(^5")	51(^3")	50(^2")
65533	85%	54(^6")	53(^5")	53(^5")	51(^3")	51(^3")
65534	90%	54(^6")	53(^5")	53(^5")	51(^3")	52(^4")
65535	95%	54(^6")	53(^5")	53(^5")	51(^3")	53(^5")
0	Basic density	48(^0")	-	-	-	-
1	105%	49(^1")	-	-	-	-
2	110%	50(^2")	-	-	-	-
3	115%	51(^3")	-	-	-	-
4	120%	52(^4")	-	-	-	-
5	125%	53(^5")	-	-	-	-
6	130%	54(^6")	-	-	-	-
7	135%	55(^7")	-	-	-	-
8	140%	56(^8")	-	-	-	-

- a=6: When printing speed is specified

Setting Status		Sending Data				
Stored Value	Print Speed	1st Byte	2nd Byte	3rd Byte	4th Byte	5th Byte
1	Speed level 1	49(^1")	-	-	-	-
2	Speed level 2	50(^2")	-	-	-	-
3	Speed level 3	51(^3")	-	-	-	-
4	Speed level 4	52(^4")	-	-	-	-
5	Speed level 5	53(^5")	-	-	-	-
6	Speed level 6	54(^6")	-	-	-	-
7	Speed level 7	55(^7")	-	-	-	-
8	Speed level 8	56(^8")	-	-	-	-
9	Speed level 9	57(^9")	-	-	-	-

- a=201: When ACK output position is specified

Setting Status		Sending Data				
Stored Value	ACK Output Position	1st Byte	2nd Byte	3rd Byte	4th Byte	5th Byte
1	ACK-in-Busy	49(^1")	-	-	-	-
2	ACK-while-Busy	50(^2")	-	-	-	-
3	ACK-after-Busy	51(^3")	-	-	-	-

- a=202: Input buffer full Busy output/cancel timing

Setting Status		Sending Data				
Stored Value	BUSY Output/Cancel	1st Byte	2nd Byte	3rd Byte	4th Byte	5th Byte
1		49(^1")	-	-	-	-
2		50(^2")	-	-	-	-
3		51(^3")	-	-	-	-
4		52(^4")	-	-	-	-

## PMU2XXX

- a=220: When maximum black mark width is specified

Setting Status		Sending Data				
Stored Value	Maximum B.M Width	1st Byte	2nd Byte	3rd Byte	4th Byte	5th Byte
0	0dot	49("1")	48("0")	48("0")	48("0")	48("0")
⋮	⋮	⋮	⋮	⋮	⋮	⋮
32767	32767dot	51("3")	50("2")	55("7")	54("6")	55("7")

- a=221: When maximum length of black mark page is specified

Setting Status		Sending Data				
Stored Value	Maximum B.M Page Length	1st Byte	2nd Byte	3rd Byte	4th Byte	5th Byte
0	0dot	49("1")	48("0")	48("0")	48("0")	48("0")
⋮	⋮	⋮	⋮	⋮	⋮	⋮
32767	32767dot	51("3")	50("2")	55("7")	54("6")	55("7")

- a=222: When head margin is specified

Setting Status		Sending Data				
Stored Value	Head Margin	1st Byte	2nd Byte	3rd Byte	4th Byte	5th Byte
0	0dot	49("1")	48("0")	48("0")	48("0")	48("0")
⋮	⋮	⋮	⋮	⋮	⋮	⋮
32767	32767dot	51("3")	50("2")	55("7")	54("6")	55("7")

- a=223: When bottom margin is specified

Setting Status		Sending Data				
Stored Value	Bottom Margin	1st Byte	2nd Byte	3rd Byte	4th Byte	5th Byte
0	0	48("0")	48("0")	48("0")	-	-
⋮	⋮	⋮	⋮	⋮	⋮	⋮
255	255	50("2")	53("5")	53("5")	-	-

- a=224: When cut distance is specified

Setting Status		Sending Data				
Stored Value	Cut Distance	1st Byte	2nd Byte	3rd Byte	4th Byte	5th Byte
0	0	48("0")	48("0")	48("0")	-	-
⋮	⋮	⋮	⋮	⋮	⋮	⋮
255	255	50("2")	53("5")	53("5")	-	-

- a=225: When head distance is specified

Setting Status		Sending Data				
Stored Value	Head Distance	1st Byte	2nd Byte	3rd Byte	4th Byte	5th Byte
0	0	48("0")	48("0")	48("0")	-	-
⋮	⋮	⋮	⋮	⋮	⋮	⋮
255	255	50("2")	53("5")	53("5")	-	-

**PMU2XXXII**

- a=5: When print density is specified

Setting Status		Sending Data				
Stored Value	Print Density	1st Byte	2nd Byte	3rd Byte	4th Byte	5th Byte
65530	70%	54(^6^)	53(^5^)	53(^5^)	51(^3^)	48(^0^)
65531	75%	54(^6^)	53(^5^)	53(^5^)	51(^3^)	49(^1^)
65532	80%	54(^6^)	53(^5^)	53(^5^)	51(^3^)	50(^2^)
65533	85%	54(^6^)	53(^5^)	53(^5^)	51(^3^)	51(^3^)
65534	90%	54(^6^)	53(^5^)	53(^5^)	51(^3^)	52(^4^)
65535	95%	54(^6^)	53(^5^)	53(^5^)	51(^3^)	53(^5^)
0	Basic density	48(^0^)	-	-	-	-
1	105%	49(^1^)	-	-	-	-
2	110%	50(^2^)	-	-	-	-
3	115%	51(^3^)	-	-	-	-
4	120%	52(^4^)	-	-	-	-
5	125%	53(^5^)	-	-	-	-
6	130%	54(^6^)	-	-	-	-
7	135%	55(^7^)	-	-	-	-
8	140%	56(^8^)	-	-	-	-

- a=6: When printing speed is specified

Setting Status		Sending Data				
Stored Value	Print Speed	1st Byte	2nd Byte	3rd Byte	4th Byte	5th Byte
1	Speed level 1	49(^1^)	-	-	-	-
2	Speed level 2	50(^2^)	-	-	-	-
3	Speed level 3	51(^3^)	-	-	-	-
4	Speed level 4	52(^4^)	-	-	-	-
5	Speed level 5	53(^5^)	-	-	-	-
6	Speed level 6	54(^6^)	-	-	-	-
7	Speed level 7	55(^7^)	-	-	-	-
8	Speed level 8	56(^8^)	-	-	-	-
9	Speed level 9	57(^9^)	-	-	-	-

- a=202: Input buffer full Busy output/cancel timing

Setting Status		Sending Data				
Stored Value	BUSY Output/Cancel	1st Byte	2nd Byte	3rd Byte	4th Byte	5th Byte
1		49(^1^)	-	-	-	-
2		50(^2^)	-	-	-	-
3		51(^3^)	-	-	-	-
4		52(^4^)	-	-	-	-

- a=220: When maximum black mark width is specified

Setting Status		Sending Data				
Stored Value	Maximum B.M Width	1st Byte	2nd Byte	3rd Byte	4th Byte	5th Byte
0	0dot	49(^1^)	48(^0^)	48(^0^)	48(^0^)	48(^0^)
⋮	⋮	⋮	⋮	⋮	⋮	⋮
32767	32767dot	51(^3^)	50(^2^)	55(^7^)	54(^6^)	55(^7^)

- a=221: When maximum length of black mark page is specified

Setting Status		Sending Data				
Stored Value	Maximum B.M Page Length	1st Byte	2nd Byte	3rd Byte	4th Byte	5th Byte
0	0dot	49(^1^)	48(^0^)	48(^0^)	48(^0^)	48(^0^)
⋮	⋮	⋮	⋮	⋮	⋮	⋮
32767	32767dot	51(^3^)	50(^2^)	55(^7^)	54(^6^)	55(^7^)

- a=222: When head margin is specified

Setting Status		Sending Data				
Stored Value	Head Margin	1st Byte	2nd Byte	3rd Byte	4th Byte	5th Byte
0	0dot	49(^1^)	48(^0^)	48(^0^)	48(^0^)	48(^0^)
⋮	⋮	⋮	⋮	⋮	⋮	⋮
32767	32767dot	51(^3^)	50(^2^)	55(^7^)	54(^6^)	55(^7^)



## PMU2XXXII

- a=223: When bottom margin is specified

Setting Status		Sending Data				
Stored Value	Bottom Margin	1st Byte	2nd Byte	3rd Byte	4th Byte	5th Byte
0	0	48(^0')	48(^0')	48(^0')	-	-
⋮	⋮	⋮	⋮	⋮	⋮	⋮
255	255	50(^2')	53(^5')	53(^5')	-	-

- a=224: When cut distance is specified

Setting Status		Sending Data				
Stored Value	Cut Distance	1st Byte	2nd Byte	3rd Byte	4th Byte	5th Byte
0	0	48(^0')	48(^0')	48(^0')	-	-
⋮	⋮	⋮	⋮	⋮	⋮	⋮
255	255	50(^2')	53(^5')	53(^5')	-	-

- a=225: When head distance is specified

Setting Status		Sending Data				
Stored Value	Head Distance	1st Byte	2nd Byte	3rd Byte	4th Byte	5th Byte
0	0	48(^0')	48(^0')	48(^0')	-	-
⋮	⋮	⋮	⋮	⋮	⋮	⋮
255	255	50(^2')	53(^5')	53(^5')	-	-

## PMU2300III

- a=5: When print density is specified

Setting Status		Sending Data				
Stored Value	Print Density	1st Byte	2nd Byte	3rd Byte	4th Byte	5th Byte
65530	70%	54(^6")	53(^5")	53(^5")	51(^3")	48(^0")
65531	75%	54(^6")	53(^5")	53(^5")	51(^3")	49(^1")
65532	80%	54(^6")	53(^5")	53(^5")	51(^3")	50(^2")
65533	85%	54(^6")	53(^5")	53(^5")	51(^3")	51(^3")
65534	90%	54(^6")	53(^5")	53(^5")	51(^3")	52(^4")
65535	95%	54(^6")	53(^5")	53(^5")	51(^3")	53(^5")
0	Basic density	48(^0")	-	-	-	-
1	105%	49(^1")	-	-	-	-
2	110%	50(^2")	-	-	-	-
3	115%	51(^3")	-	-	-	-
4	120%	52(^4")	-	-	-	-
5	125%	53(^5")	-	-	-	-
6	130%	54(^6")	-	-	-	-
7	135%	55(^7")	-	-	-	-
8	140%	56(^8")	-	-	-	-

- a=6: When printing speed is specified

Setting Status		Sending Data				
Stored Value	Print Speed	1st Byte	2nd Byte	3rd Byte	4th Byte	5th Byte
1	Speed level 1	49(^1")	-	-	-	-
2	Speed level 2	50(^2")	-	-	-	-
3	Speed level 3	51(^3")	-	-	-	-
4	Speed level 4	52(^4")	-	-	-	-
5	Speed level 5	53(^5")	-	-	-	-
6	Speed level 6	54(^6")	-	-	-	-
7	Speed level 7	55(^7")	-	-	-	-
8	Speed level 8	56(^8")	-	-	-	-
9	Speed level 9	57(^9")	-	-	-	-

- a=130: When the auto retraction time length is specified.

Setting Status		Sending Data				
Stored Value	Auto retraction time	1st Byte	2nd Byte	3rd Byte	4th Byte	5th Byte
0	0	48(^0")	48(^0")	48(^0")	48(^0")	48(^0")
1	100ms	48(^0")	48(^0")	48(^0")	48(^0")	49(^1")
⋮	⋮	⋮	⋮	⋮	⋮	⋮
32767	3276700ms	51(^3")	50(^2")	55(^7")	54(^6")	55(^7")

- a=131: When the time length of bezel LED ON at waiting is specified.

Setting Status		Sending Data				
Stored Value	Bezel LED ON time	1st Byte	2nd Byte	3rd Byte	4th Byte	5th Byte
0	0	48(^0")	48(^0")	48(^0")	48(^0")	48(^0")
1	100ms	48(^0")	48(^0")	48(^0")	48(^0")	49(^1")
⋮	⋮	⋮	⋮	⋮	⋮	⋮
32767	3276700ms	51(^3")	50(^2")	55(^7")	54(^6")	55(^7")

- a=132: When the time length of bezel LED ON at blinking is specified.

Setting Status		Sending Data				
Stored Value	Bezel LED blinking ON time	1st Byte	2nd Byte	3rd Byte	4th Byte	5th Byte
2	200ms	48(^0")	48(^0")	48(^0")	48(^0")	50(^2")
⋮	⋮	⋮	⋮	⋮	⋮	⋮
3000	300000ms	48(^0")	51(^3")	48(^0")	48(^0")	48(^0")

### PMU2300III

•a=133:When the time length of bezel LED OFF at blinking is specified.

Setting Status		Sending Data				
Stored Value	Bezel LED Blinking OFF time	1st Byte	2nd Byte	3rd Byte	4th Byte	5th Byte
2	200ms	48(^0')	48(^0')	48(^0')	48(^0')	50(^2')
⋮	⋮	⋮	⋮	⋮	⋮	⋮
3000	300000ms	48(^0')	51(^3')	48(^0')	48(^0')	48(^0')

•a=134:When the state of bezel LED at waiting is specified.

Setting Status		Sending Data				
Stored Value	Bezel LED state	1st Byte	2nd Byte	3rd Byte	4th Byte	5th Byte
0	OFF	48(^0')	48(^0')	48(^0')	48(^0')	48(^0')
1	ON	48(^0')	48(^0')	48(^0')	48(^0')	49(^1')
2	Blinking	48(^0')	48(^0')	48(^0')	48(^0')	50(^2')

•a=135:When the state of bezel LED at printing is specified.

Setting Status		Sending Data				
Stored Value	Bezel LED state	1st Byte	2nd Byte	3rd Byte	4th Byte	5th Byte
0	OFF	48(^0')	48(^0')	48(^0')	48(^0')	48(^0')
1	ON	48(^0')	48(^0')	48(^0')	48(^0')	49(^1')
2	Blinking	48(^0')	48(^0')	48(^0')	48(^0')	50(^2')

•a=136:When the state of bezel LED at ejecting is specified.

Setting Status		Sending Data				
Stored Value	Bezel LED state	1st Byte	2nd Byte	3rd Byte	4th Byte	5th Byte
0	OFF	48(^0')	48(^0')	48(^0')	48(^0')	48(^0')
1	ON	48(^0')	48(^0')	48(^0')	48(^0')	49(^1')
2	Blinking	48(^0')	48(^0')	48(^0')	48(^0')	50(^2')

• a=202: Input buffer full Busy output/cancel timing

Setting Status		Sending Data				
Stored Value	BUSY Output/Cancel	1st Byte	2nd Byte	3rd Byte	4th Byte	5th Byte
1		49(^1')	-	-	-	-
2		50(^2')	-	-	-	-
3		51(^3')	-	-	-	-
4		52(^4')	-	-	-	-

• a=213: When the flow control of virtual COM is specified.

Setting Status		Sending Data				
Stored Value	Flow control	1st Byte	2nd Byte	3rd Byte	4th Byte	5th Byte
1	PC setting	49(^1')	-	-	-	-
2	DTR/DSR	50(^2')	-	-	-	-
3	XON/XOF	51(^3')	-	-	-	-

• a=214: When Kanji is specified

Setting Status		Sending Data				
Stored Value	Kanji	1st Byte	2nd Byte	3rd Byte	4th Byte	5th Byte
1	OFF	49(^1')	-	-	-	-
2	ON	50(^2')	-	-	-	-

### PMU2300III

• a=216: When JIS/Shift JIS is specified

Setting Status		Sending Data				
Stored Value	JIS/Shift JIS	1 <sup>st</sup> Byte	2nd Byte	3rd Byte	4th Byte	5th Byte
1	JIS	49(^1")	-	-	-	-
2	Shift JIS	50(^2")	-	-	-	-

• a=217: When international character set is specified

Setting Status		Sending Data				
Stored Value	Int'l char. set	1st Byte	2nd Byte	3rd Byte	4th Byte	5th Byte
1	U.S.A.	49(^1")	-	-	-	-
2	France	50(^2")	-	-	-	-
3	Germany	51(^3")	-	-	-	-
4	U.K.	52(^4")	-	-	-	-
5	Denmark I	53(^5")	-	-	-	-
6	Sweden	54(^6")	-	-	-	-
7	Italy	55(^7")	-	-	-	-
8	Spain I	56(^8")	-	-	-	-
9	Japan	57(^9")	-	-	-	-
10	Norway	49(^1")	48(^0")	-	-	-
11	Denmark II	49(^1")	49(^1")	-	-	-
12	Spain II	49(^1")	50(^2")	-	-	-
13	Latin America	49(^1")	51(^3")	-	-	-
14	Korea	49(^1")	52(^4")	-	-	-
15	Croatia	49(^1")	53(^5")	-	-	-
16	P.R.China	49(^1")	54(^6")	-	-	-

• a=218: When codepage is specified

Setting Status		Sending Data				
Stored Value	Codepage	1st Byte	2nd Byte	3rd Byte	4th Byte	5th Byte
1	Codepage PC437	49(^1")	-	-	-	-
2	Katakana	50(^2")	-	-	-	-
3	Codepage PC850	51(^3")	-	-	-	-
4	Codepage PC860	52(^4")	-	-	-	-
5	Codepage PC863	53(^5")	-	-	-	-
6	Codepage PC865	54(^6")	-	-	-	-
7	Codepage PC852	55(^7")	-	-	-	-
8	Codepage PC866	56(^8")	-	-	-	-
9	Codepage PC857	57(^9")	-	-	-	-
10	WPC1252	49(^1")	48(^0")	-	-	-
11	Space page	49(^1")	49(^1")	-	-	-
12	Codepage PC864	49(^1")	50(^2")	-	-	-
13	Thaicode18	49(^1")	51(^3")	-	-	-

• a=220: When maximum black mark width is specified

Setting Status		Sending Data				
Stored Value	Maximum B.M Width	1st Byte	2nd Byte	3rd Byte	4th Byte	5th Byte
0	0dot	49(^1")	48(^0")	48(^0")	48(^0")	48(^0")
⋮	⋮	⋮	⋮	⋮	⋮	⋮
32767	32767dot	51(^3")	50(^2")	55(^7")	54(^6")	55(^7")

• a=221: When maximum black mark page length is specified

Setting Status		Sending Data				
Stored Value	Maximum B.M page length	1st Byte	2nd Byte	3rd Byte	4th Byte	5th Byte
0	0dot	49(^1")	48(^0")	48(^0")	48(^0")	48(^0")
⋮	⋮	⋮	⋮	⋮	⋮	⋮
32767	32767dot	51(^3")	50(^2")	55(^7")	54(^6")	55(^7")

**PMU2300III**

- a=222: When head margin is specified

Setting Status		Sending Data				
Stored Value	Head Margin	1st Byte	2nd Byte	3rd Byte	4th Byte	5th Byte
0	0dot	49(^1")	48(^0")	48(^0")	48(^0")	48(^0")
⋮	⋮	⋮	⋮	⋮	⋮	⋮
32767	32767dot	51(^3")	50(^2")	55(^7")	54(^6")	55(^7")

- a=223: When bottom margin is specified

Setting Status		Sending Data				
Stored Value	Bottom Margin	1st Byte	2nd Byte	3rd Byte	4th Byte	5th Byte
0	0dot	49(^1")	48(^0")	48(^0")	48(^0")	48(^0")
⋮	⋮	⋮	⋮	⋮	⋮	⋮
32767	32767dot	51(^3")	50(^2")	55(^7")	54(^6")	55(^7")

- a=224: When cut distance is specified

Setting Status		Sending Data				
Stored Value	Cut Distance	1st Byte	2nd Byte	3rd Byte	4th Byte	5th Byte
0	0dot	49(^1")	48(^0")	48(^0")	48(^0")	48(^0")
⋮	⋮	⋮	⋮	⋮	⋮	⋮
32767	32767dot	51(^3")	50(^2")	55(^7")	54(^6")	55(^7")

- a=225: When head distance is specified

Setting Status		Sending Data				
Stored Value	Head Distance	1st Byte	2nd Byte	3rd Byte	4th Byte	5th Byte
0	0dot	49(^1")	48(^0")	48(^0")	48(^0")	48(^0")
⋮	⋮	⋮	⋮	⋮	⋮	⋮
32767	32767dot	51(^3")	50(^2")	55(^7")	54(^6")	55(^7")

## CT-P29x series

- a=5: When print density is specified

Setting Status		Sending Data				
Stored Value	Print Density	1st Byte	2nd Byte	3rd Byte	4th Byte	5th Byte
65530	70%	54(^6^)	53(^5^)	53(^5^)	51(^3^)	48(^0^)
65531	75%	54(^6^)	53(^5^)	53(^5^)	51(^3^)	49(^1^)
65532	80%	54(^6^)	53(^5^)	53(^5^)	51(^3^)	50(^2^)
65533	85%	54(^6^)	53(^5^)	53(^5^)	51(^3^)	51(^3^)
65534	90%	54(^6^)	53(^5^)	53(^5^)	51(^3^)	52(^4^)
65535	95%	54(^6^)	53(^5^)	53(^5^)	51(^3^)	53(^5^)
0	Basic density	48(^0^)	-	-	-	-
1	105%	49(^1^)	-	-	-	-
2	110%	50(^2^)	-	-	-	-
3	115%	51(^3^)	-	-	-	-
4	120%	52(^4^)	-	-	-	-
5	125%	53(^5^)	-	-	-	-
6	130%	54(^6^)	-	-	-	-
7	135%	55(^7^)	-	-	-	-
8	140%	56(^8^)	-	-	-	-

- a=6: When printing speed is specified

Setting Status		Sending Data				
Stored Value	Print Speed	1st Byte	2nd Byte	3rd Byte	4th Byte	5th Byte
1	Speed level 1	49(^1^)	-	-	-	-
2	Speed level 2	50(^2^)	-	-	-	-
3	Speed level 3	51(^3^)	-	-	-	-
4	Speed level 4	52(^4^)	-	-	-	-
5	Speed level 5	53(^5^)	-	-	-	-
6	Speed level 6	54(^6^)	-	-	-	-
7	Speed level 7	55(^7^)	-	-	-	-
8	Speed level 8	56(^8^)	-	-	-	-
9	Speed level 9	57(^9^)	-	-	-	-

- a=213: When the flow control of virtual COM is specified.

Setting Status		Sending Data				
Stored Value	Flow control	1st Byte	2nd Byte	3rd Byte	4th Byte	5th Byte
1	PC setting	49(^1^)	-	-	-	-
2	DTR/DSR	50(^2^)	-	-	-	-
3	XON/XOF	51(^3^)	-	-	-	-

- a=214: When Kanji is specified

Setting Status		Sending Data				
Stored Value	Kanji	1st Byte	2nd Byte	3rd Byte	4th Byte	5th Byte
1	OFF	49(^1^)	-	-	-	-
2	ON	50(^2^)	-	-	-	-

- a=216: When JIS/Shift JIS is specified

Setting Status		Sending Data				
Stored Value	JIS/Shift JIS	1st Byte	2nd Byte	3rd Byte	4th Byte	5th Byte
1	JIS	49(^1^)	-	-	-	-
2	Shift JIS	50(^2^)	-	-	-	-

### CT-P29x series

- a=217: When international character set is specified

Setting Status		Sending Data				
Stored Value	Int'l char. set	1st Byte	2nd Byte	3rd Byte	4th Byte	5th Byte
1	U.S.A.	49(^1")	-	-	-	-
2	France	50(^2")	-	-	-	-
3	Germany	51(^3")	-	-	-	-
4	U.K.	52(^4")	-	-	-	-
5	Denmark I	53(^5")	-	-	-	-
6	Sweden	54(^6")	-	-	-	-
7	Italy	55(^7")	-	-	-	-
8	Spain I	56(^8")	-	-	-	-
9	Japan	57(^9")	-	-	-	-
10	Norway	49(^1")	48(^0")	-	-	-
11	Denmark II	49(^1")	49(^1")	-	-	-
12	Spain II	49(^1")	50(^2")	-	-	-
13	Latin America	49(^1")	51(^3")	-	-	-
14	Korea	49(^1")	52(^4")	-	-	-
15	Croatia	49(^1")	53(^5")	-	-	-
16	P.R.China	49(^1")	54(^6")	-	-	-

- a=218: When codepage is specified

Setting Status		Sending Data				
Stored Value	Codepage	1st Byte	2nd Byte	3rd Byte	4th Byte	5th Byte
1	Codepage PC437	49(^1")	-	-	-	-
2	Katakana	50(^2")	-	-	-	-
3	Codepage PC850	51(^3")	-	-	-	-
4	Codepage PC860	52(^4")	-	-	-	-
5	Codepage PC863	53(^5")	-	-	-	-
6	Codepage PC865	54(^6")	-	-	-	-
7	Codepage PC852	55(^7")	-	-	-	-
8	Codepage PC866	56(^8")	-	-	-	-
9	Codepage PC857	57(^9")	-	-	-	-
10	WPC1252	49(^1")	48(^0")	-	-	-
11	Space page	49(^1")	49(^1")	-	-	-
12	Codepage PC864	49(^1")	50(^2")	-	-	-
13	Thaicode18	49(^1")	51(^3")	-	-	-

# GS ( E pL pH fn a d1 d2

**[Code]** <1D>H<28>H<45>H<pL><pH><fn><a><d1><d2>

**[Range]** (pL+pH×256)=4 (pL=4, pH=0)  
fn=7  
a=10, 12, 17

- [Outline]** **[The specification which is common to the model]**
- Copies the data of user-defined code page in the font specified by "a".
  - Configuration of customized value No.

d1	d2	Function
31	30	Loads the character code page data specified by "a" in storage area to work area.
30	31	Saves the character code page data in work area to the storage area of the font specified by "a".

- Work area: Area where data is initialized by power OFF or resetting (initialize).  
Operation is made in accordance with the data set in this area.
- Storage area: Area where data is not initialized by power OFF or resetting (initialize).
- User-defined code page: Page 255 (ESC t 255)
- This function operates only in printer function setting mode.

**[The specification which depend on the model]**

**CT-S300/CT-S310/CT-S801/CT-S851/CT-S601/CT-S651/CT-P29x series**

a	Font Type
10	Font B: 9 (horizontal)×17 (vertical)
12	Font A: 12 (horizontal)×24 (vertical)
17	Font C: 8 (horizontal)×16 (vertical)

**CT-S280/CT-S281/CT-S2000/CT-S4000/BD2-2220/PMU series/CT-S310II**

a	Font Type
10	Font B: 9 (horizontal)×24 (vertical)
12	Font A: 12 (horizontal)×24 (vertical)
17	Font C: 8 (horizontal)×16 (vertical)



**fn=8: Function 8 Defining Data by the Column Format to Character Code Page of Work Area**

**GS ( E pL pH fn y c1 c2 [xd1...d(y×x)] k**

**[Code]** <1D>H<28>H<45>H<pL><pH><fn><y><c1><c2> [<x><d1>..<<d(y×x)>] <k>

**[Range]** 5≤(pL+pH×256)≤65535  
 fn=8  
 y=2 (At selection of font C)  
 y=3 (At selection of other than font C)  
 128≤c1≤c2≤255  
 0≤x≤12 (At selection of font A)  
 0≤x≤9 (At selection of font B)  
 0≤x≤8 (At selection of font C)  
 0≤d≤255  
 k=c2-c1+1

- [Outline]** **[The specification which is common to the model]**
- Defines the data in column format in units of character on the code page in RAM.
  - Operates only in printer function setting mode.

Data structure(9×17)  
 d1 d4 .....d25  
 d3 d6 .....d27

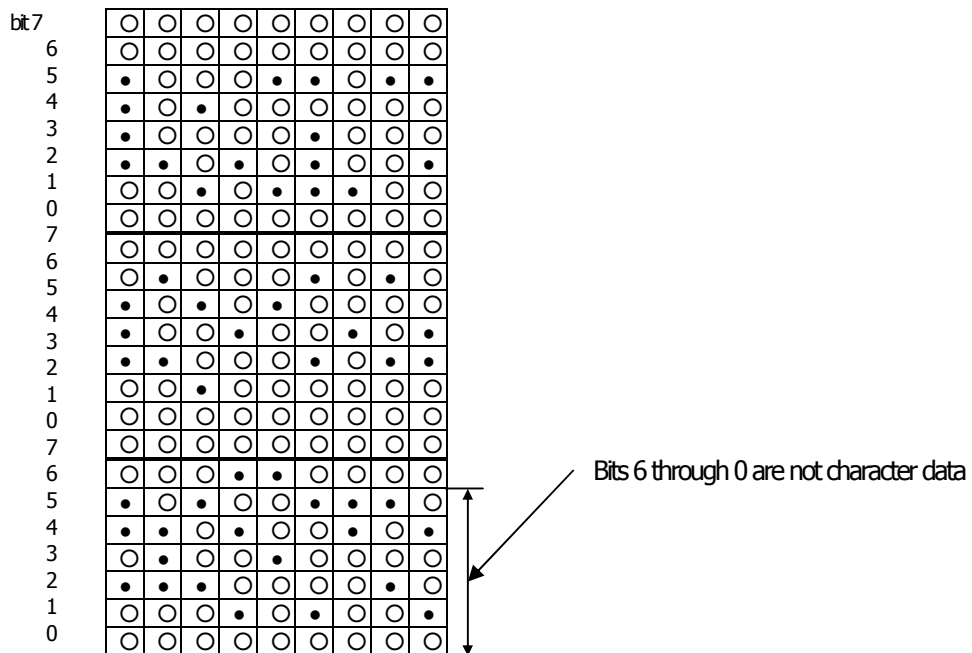

**fn=9: Function 9 Defining Data in the Raster Format to the Character Code Page of Work Area**

**GS ( E pL pH fn x c1 c2 [y d1...d(x×y)] k**

**[Code]** <1D>H<28>H<45>H<pL><pH><fn><x><c1><c2> [<y><d1>..

**[Range]**  $5 \leq (pL+pH \times 256) \leq 65535$   
 $fn=9$   
 $x=1$  (At selection of font C),  $x=2$  (At selection of other than font C)  
 $128 \leq c1 \leq c2 \leq 255$   
 $0 \leq y \leq 24$  (At selection of font A)  
 $0 \leq y \leq 16$  (At selection of font C),  $0 \leq d \leq 255$   
 $k=c2-c1+1$   
**CT-S300/CT-S310/CT-S801/CT-S851/CT-S601/CT-S651/ CT-P29x series**  
 $0 \leq x \leq 17$  (At selection of font B)  
**CT-S280/CT-S281/CT-S2000/CT-S4000/BD2-2220/PMU series/CT-S310II**  
 $0 \leq x \leq 24$  (At selection of font B)

- [Outline]** **[The specification which is common to the model]**
- Defines the data in raster format in units of character on the character code page in work area.
  - Operates only in printer function setting mode.

Data structure(12×24)

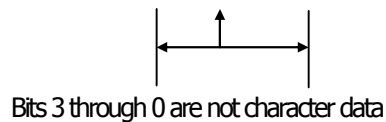
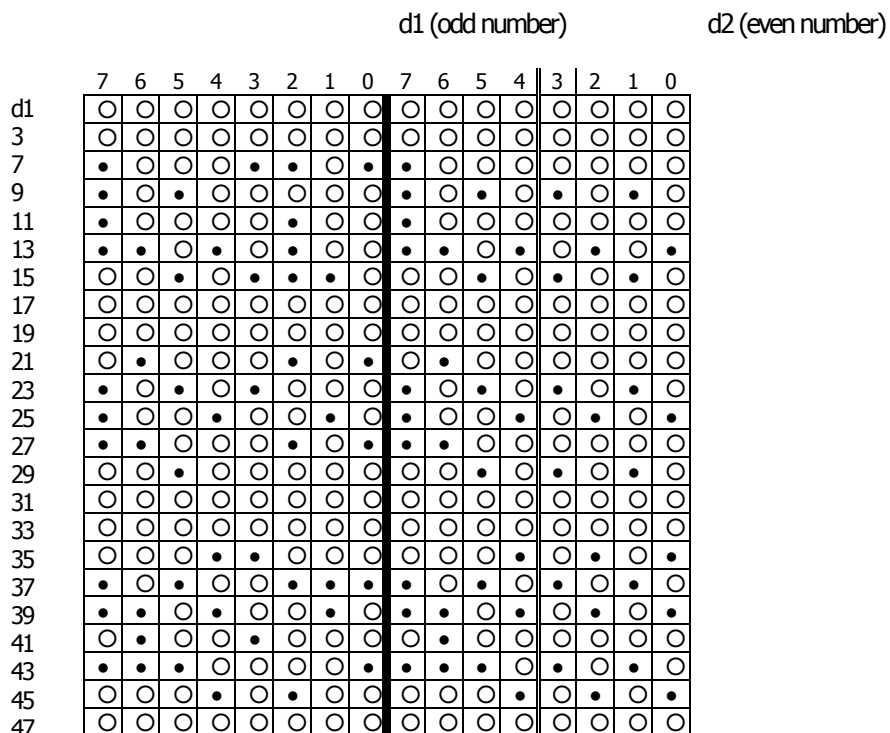

**fn=10: Function 10 Erasing Data of Character Code Page Data in Work Area**

# **GS ( E pL pH fn c1 c2**

---

**[Code]** <1D>H<28>H<45>H<pL><pH><fn><c1><c2>

**[Range]** (pL+pH×256)=3  
fn=10  
128≤c1≤c2≤255

**[Outline]** **[The specification which is common to the model]**

- Erases (set to space) data in units of character on the character code page in work area.
- Operates only in printer function setting mode.

## fn=11: Function 11 Setting Communication Conditions

# GS ( E pL pH fn a d1...dk

**[Code]** <1D>H<28>H<45>H<pL><pH><fn><a><d1>...<dk>

**[Range]**  $3 \leq (pL + pH \times 256) \leq 65535$  ( $0 \leq pL \leq 255$ ,  $0 \leq pH \leq 255$ )  
 fn=11  
 $1 \leq a \leq 4$  (Not changed in other than specified range)  
 $48 \leq d \leq 57$  (Not changed in other than specified range)  
 $1 \leq k \leq 6$

**[Outline]** **[The specification which is common to the model]**

- Sets the communication conditions of serial interface specified by "a".
- a=1: Setting baud rate

Baud Rate	d1	d2	d3	d4	d5	d6
⊙1200	49("1")	50("2")	48("0")	48("0")	-	-
2400	50("2")	52("4")	48("0")	48("0")	-	-
4800	52("4")	56("8")	48("0")	48("0")	-	-
▲9600	57("9")	54("6")	48("0")	48("0")	-	-
△19200	49("1")	57("9")	50("2")	48("0")	48("0")	-
38400	51("3")	56("8")	52("4")	48("0")	48("0")	-
●57600	53("5")	55("7")	54("6")	48("0")	48("0")	-
●115200	49("1")	49("1")	53("5")	50("2")	48("0")	48("0")

⊙—support by CT-S280, CT-S281, CT-S2000, CT-S4000, CT-S801, CT-S851, CT-S601, CT-S651, CT-S310II

●—support by CT-S280, CT-S2000, CT-S4000, CT-S801, CT-S851, CT-S601, CT-S651, PMU series, CT-S310II

\* PMU2XXX: Prohibit the use of 57600. CT-P29x series does not support 115200bps.

△—Default : CT-S300, CT-S310, CT-S2000(JPN/EUR), CT-S4000(JPN/EUR)

▲—Default : CT-S280, CT-S281, CT-S2000(USA), CT-S4000(USA), CT-S801, CT-S851, CT-S601, CT-S651, BD2-2220, PMU series, CT-P29x series, CT-S310II

- a=2: Setting to specified parity

d1	Parity Setting
48 (Default)	No parity
49	Odd parity
50	Even parity

- a=3: Setting to specified flow control

d1	Flow Control
48 (Default)	DSR/DTR
49	XON/XOFF

- a=4: Setting to specified data length

d1	Setting Data Length
55	7-bit length
56 (Default)	8-bit length

- Operates only in printer function setting mode.
- Which of dip SW or memory SW is used at initialization depends on "Selecting communication condition setting" of dip SW1-1.

## fn=12: Function 12 Sending the Set Communication Conditions

# GS ( E pL pH fn a

**[Code]** <1D>H<28>H<45>H<pL><pH><fn><a>

**[Range]** (pL+pH×256)=2 (pL=2, pH=0)  
fn=12  
1≤a≤4 (Does not send in other than specified range)

**[Outline]** **[The specification which is common to the model]**  
• Sends communication conditions of serial interface specified by "a".

	Hex.	No. of Data
Header	37H	1
ID	33H	1
Kind of communication conditions (a)	31H("1") to 34H("4")	1
Separation number	1FH	1
Set value	30H to 39H	1 to 6
NULL	00H	1

### • Set value

a=1: At specification of baud rate

Baud Rate	d1	d2	d3	d4	D5	d6
⊙1200	49("1")	50("2")	48("0")	48("0")	-	-
2400	50("2")	52("4")	48("0")	48("0")	-	-
4800	52("4")	56("8")	48("0")	48("0")	-	-
9600	57("9")	54("6")	48("0")	48("0")	-	-
19200 (Default)	49("1")	57("9")	50("2")	48("0")	48("0")	-
38400	51("3")	56("8")	52("4")	48("0")	48("0")	-
●57600	53("5")	55("7")	54("6")	48("0")	48("0")	-
●115200	49("1")	49("1")	53("5")	50("2")	48("0")	48("0")

⊙—support by **CT-S280, CT-S281, CT-S2000, CT-S4000, CT-S801, CT-S851, CT-S601, CT-S651, CT-S310II**

●—support by **CT-S280, CT-S2000, CT-S4000, PMU series, CT-P29x series, CT-S310II**

(**PMU2XXX does not support 57600bps. CT-P29x series does not support 115200bps**)

a=2: At specification of parity

d1	Parity Setting
48	No parity
49	Odd parity
50	Even parity

a=3: At specification of flow control

d1	Flow Control
48	DTR/DSR
49	XON/XOFF

a=4: At specification of data length

d1	Setting Data Length
48	7-bit length
49	8-bit length

## fn=255: Function 255 Setting All Contents Set by Printer Function Setting Mode to the State at Shipment

# GS ( E pL pH fn a

---

**[Code]** <1D>H<28>H<45>H<pL><pH><fn><a>

**[Range]** (pL+pH×256)=2  
fn=255  
a=3, 5, 11, 255

**[Outline]** **[The specification which is common to the model]**

- Restores various kinds of function set by printer function setting mode to the setting at the time of shipment (initial value described in User's Manual).

<b>a</b>	<b>Function</b>
3	Memory switch
5	Customized value
7	Character code
11	Communication conditions of serial interface
255	Sets all contents set in printer function setting mode to the state at the time of shipment.

# GS ( K pL pH fn m

Support model	CT-S280	CT-S300	CT-S2000	CT-S4000	BD2-2220	PMU series
	CT-S281	CT-S310	CT-S801/851	CT-S601/651	CT-P29x series	CT-S310 II

**[Function]** Selecting print control method

**[Outline]** **[The specification which is common to the model]**  
Executes the setting related to the print control specified by the value of "fn".

Function No. (fn)	Function
<a href="#">Function 49</a>	Sets printing density.
<a href="#">Function 50</a>	Sets printing speed.
<a href="#">Function 97</a>	Sets the number of divisions for head conducting.*

\*fn=97 is supported by only CT-S300, CT-S310

**fn=49: Function 49 Setting Printing Density**

# GS ( K pL pH fn m

**[Code]** <1D>H<28>H<4B>H<pL><pH><fn><m>

**[Range]** (pL+pH×256)=2 (pL=2, pH=0)  
fn=49  
0≤m≤8, 250≤m≤255

**[Default]** m=0 (Customized value setting value)

**[Outline]** **[The specification which is common to the model]**

- Sets printing density.

m	Printing Density
250	Selects density level -6 (70%)
251	Selects density level -5 (75%)
252	Selects density level -4 (80%)
253	Selects density level -3 (85%)
254	Selects density level -2 (90%)
255	Selects density level -1 (95%)
0	Selects standard density (100%)
1	Selects density level + 1 (105%)
2	Selects density level + 2 (110%)
3	Selects density level + 3 (115%)
4	Selects density level + 4 (120%)
5	Selects density level + 5 (125%)
6	Selects density level + 6 (130%)
7	Selects density level + 7 (135%)
8	Selects density level + 8 (140%)



## fn=50: Function 50 Setting Printing Speed

# GS ( K pL pH fn m

---

**[Code]** <1D>H<28>H<4B>H<pL><pH><fn><m>

**[Range]** (pL+pH×256)=2 (pL=2, pH=0)  
fn=50  
0≤m≤9, 48≤m≤57

**[Default]** m=0 (Customized value setting)

**[Outline]** **[The specification which is common to the model]**

- Sets printing speed.

m	Printing Speed
0, 48	Selects customized value setting
1, 49	Selects printing speed level 1.
2, 50	Selects printing speed level 2.
3, 51	Selects printing speed level 3.
4, 52	Selects printing speed level 4.
5, 53	Selects printing speed level 5.
6, 54	Selects printing speed level 6.
7, 55	Selects printing speed level 7.
8, 56	Selects printing speed level 8.
9, 57	Selects printing speed level 9.

## fn=97: Function 97 Setting Number of Divisions for Head Conducting

# GS ( K pL pH fn m

---

**[Code]** <1D>H<28>H<4B>H<pL><pH><fn><m>

**[Range]** (pL+pH×256)=2 (pL=2, pH=0)  
fn=97  
m=0, 24, 48, 50, 52

**[Default]** m=0 (Customized value setting)

**[Outline]** **[The specification which depend on the model]**

### **CT-S300/CT-S310**

- Sets the number of divisions for head conducting.

<b>m</b>	<b>No. of Divisions for Head Conducting</b>
0, 48	Selects customized value setting
2, 50	Selects 2-division conducting.
4, 52	Selects 4-division conducting.

# GS ( M pL pH fn m

Support model	CT-S280	CT-S300	CT-S2000	CT-S4000	BD2-2220	PMU series
	CT-S281	CT-S310	CT-S801/851	CT-S601/651	CT-P29x series	CT-S310 II

**[Function]** Customizing the printer

**[Outline]** **[The specification which is common to the model]**

- Executes processing related to escape/recovery of the value set in the work area or the data defined by various kinds of command.

fn	Function
<a href="#">Function 1</a>	Copies the set value stored in work area to the storage area.
<a href="#">Function 2</a>	Copies the set value stored in storage area to the work area.
<a href="#">Function 3</a>	Specifies the auto loading function of the set value at initialization to be valid or invalid.

- Work area:  
Area where data is initialized by power OFF of resetting (initialize). Operation is made in accordance with the data set in this area.
- Storage area:  
Area where data is not initialized by power OFF or resetting (initialize).

## Commands for this function

Command Type	Command
Status relations	ESC c3, GS a
Macro registration	GS :
Character type	ESC M, ESC R, ESC t
Font attribute	ESC !, ESC -, ESC E, ESC G, ESC V, ESC {, GS !, GS B, GS b, GS ( N*
Line feed amount, character space	ESC SP, ESC 2, ESC 3
Barcode	GS H, GS f, GS h, GS w
2-dimensional code(**)	GS ( k<fn65 to 70>
Print position	ESC D, ESC T, ESC a, GS L, GS W
Kanji control relations	FS !, FS &, FS ( A, FS -, FS ., FS C, FS S, FS W
Other	ESC c 4, ESC c 5, GS ( D, GS ( H <fn49>, GS P

\*\* ... Supported with CT-S2000 and CT-S4000 label models.

\* ... Not supported with BD2-2220.

**fn=1, 49: Function 1 Copies the set value stored in work area to the storage area**

## **GS ( M pL pH fn m**

---

**[Code]** <1D>H<28>H<4D>H<pL><pH><fn><m>

**[Range]** (pL+pH×256)=2 (pL=2, pH=0)  
fn=1, 49  
m=1, 49

**[Outline]** **[The specification which is common to the model]**  
• Copies the set value stored in work area to the storage area.

**[Caution]**

- This command allows writing to non-volatile memory. Therefore, using this command frequently may result in breakage of non-volatile memory. Use this command appropriately [10 times max./day].
- During execution of this command, the printer is in Busy state and stops receiving operation. Therefore, data transmission from the host is prohibited.

**fn=2, 50: Function 2 Copies the set value stored in storage area to the work area**

## **GS ( M pL pH fn m**

---

**[Code]** <1D>H<28>H<4D>H<pL><pH><fn><m>

**[Range]** (pL+pH×256)=2 (pL=2, pH=0)  
fn=2, 50  
m=0, 1, 48, 49

**[Outline]** **[The specification which is common to the model]**  
• Changes the set value of work area by the value of "m".

<b>m</b>	<b>Function</b>
0, 48	Sets all set values of work area to the initial value described in the specification.
1, 49	Copies the set value stored in storage area to the work area. When there is no set value in storage area, sets the value to the initial value described in the specification.

**fn=3, 51: Function 3 Specifies the auto loading function of the set value at initialization to be valid or invalid**

## **GS ( M pL pH fn m**

---

**[Code]** <1D>H<28>H<4D>H<pL><pH><fn><m>

**[Range]** (pL+pH×256)=2 (pL=2, pH=0)  
fn=3, 51  
m=0, 1, 48, 49

**[Outline]** **[The specification which is common to the model]**  
• Determines the setting of storage area at initialization to the work area by the value of "m".

<b>m</b>	<b>Function</b>
0, 48	Does not copy data from storage area to work area at initialization.
1, 49	Copies data from storage area to work area at initialization.

# GS ( N pL pH fn m

Support model	CT-S280	CT-S300	CT-S2000	CT-S4000	BD2-2220	PMU series
	CT-S281	CT-S310	CT-S801/851	CT-S601/651	CT-P29x series	CT-S310 II

**[Function]** Designating font attribute

**[Outline]** **[The specification which is common to the model]**  
 • Executes processing of font attribute by the specified fn value.

fn	Function
48	Selects character color.

**fn=48: Function 48 Selects character color**

# GS ( N pL pH fn m

**[Code]** <1D>H<28>H<4E>H<pL><pH><fn><m>

**[Range]** (pL+pH×256)=2 (pL=2, pH=0)  
 fn=48  
 m=49 (At single color paper setting)  
 m=49, 50 (At 2-color paper setting)

**[Default]** m=49

**[Outline]** **[The specification which is common to the model]**  
 • Prints the succeeding characters with the energy set in m.

m	Function
49	High energy
50	Low energy

## 2.2.17 2-dimensional code Commands

# GS ( k pL pH cn fn [parameter]

Support model	CT-S280	CT-S300	CT-S2000	CT-S4000	BD2-2220	PMU series
	CT-S281	CT-S310	CT-S801/851	CT-S601/651	CT-P29x series	CT-S310 II

**[Function]** Setting and printing 2-dimensional code

**[Outline]** **[The specification which is common to the model]**

- Executes processing specified by function code (fn) with the 2-dimensional code specified by cn.
- 2-dimensional codes selectable with the value of cn are shown below.

cn	2-dimensional code
48	PDF417
49	QRCode

**[The specification which depend on the model]**

**CT-S801/CT-S851/CT-S601/CT-S651/CT-S310 II**

cn	2-dimensional code
48	PDF417
49	QRCode
51	GS1 DataBar

- Executes various processing related to 2-dimensional code specified by fn.

cn	fn	Code	Function No.	Function
48	65	GS ( k pL pH cn fn n	<a href="#">Function65</a>	Sets the number of digits of PDF417.
	66	GS ( k pL pH cn fn n	<a href="#">Function66</a>	Sets the number of steps of PDF417.
	67	GS ( k pL pH cn fn n	<a href="#">Function67</a>	Sets the module width of PDF417.
	68	GS ( k pL pH cn fn n	<a href="#">Function68</a>	Sets the height of the step of PDF417.
	69	GS ( k pL pH cn fn m n	<a href="#">Function69</a>	Sets error correction level of PDF417.
	70	GS ( k pL pH cn fn m	<a href="#">Function70</a>	Sets the option of PDF417.
	80	GS ( k pL pH cn fn m d1 ... dk	<a href="#">Function80</a>	Stores received PDF417 data to 2-dimensional code data storage area *.
	81	GS ( k pL pH cn fn m	<a href="#">Function81</a>	Prints PDF417 data* of 2-dimensional code data storage area.
82	GS ( k pL pH cn fn m	<a href="#">Function82</a>	Sends size information of PDF417 data in 2-dimensional code data storage area.	

cn	fn	Code	Function No.	Function
49	65	GS ( k pL pH cn fn n1 n2	<a href="#">Function165</a>	Specifies QRCode model.
	67	GS ( k pL pH cn fn n	<a href="#">Function167</a>	Sets the size of QRCode module.
	69	GS ( k pL pH cn fn m n	<a href="#">Function169</a>	Sets error correction level of QRCode.
	80	GS ( k pL pH cn fn m d1 ... dk	<a href="#">Function180</a>	Stores received QRCode data to 2-dimensional code data storage area.
	81	GS ( k pL pH cn fn m	<a href="#">Function181</a>	Prints QRCode data in 2-dimensional code data storage area.
	82	GS ( k pL pH cn fn m	<a href="#">Function182</a>	Sends the size information of QRCode data in 2-dimensional code data storage area.

cn	fn	Code	Function No.	Function
51	67	GS ( k pL pH cn fn n	<a href="#">Function367</a>	Sets the module width of GS1 DataBar
	71	GS ( k pL pH cn fn nL nH	<a href="#">Function371</a>	Sets the maximum width of GS1 DataBar Expanded Stacked
	80	GS ( k pL pH cn fn m n d1 ... dk	<a href="#">Function380</a>	Stores received GS1 DataBar data to 2-dimensional code data storage area.
	81	GS ( k pL pH cn fn m	<a href="#">Function381</a>	Prints GS1 DataBar data in 2-dimensional code data storage area.
	82	GS ( k pL pH cn fn m	<a href="#">Function382</a>	Sends the size information of GS1 DataBar data in 2-dimensional code data storage area.

\* PDF417 data ... Indicates data (d1 ... dk) of [cn=48: Function 80] .

\* 2-dimensional code data storage area ... Indicates the area where [cn=48: Function 80] , [cn=49: Function 180] , and [cn=51: Function 380] data are stored.

\* QRCode data ... Indicates data (d1 ... dk) of [cn=49: Function 180] .

\* GS1 DataBar data ...Indicates data (d1 ... dk) of [cn=51: Function 380] .

**[Caution]**

**[The specification which is common to the model]**

**PMU2XXXII/PMU2300III**

- Among PMU series, only PMU2xxxx type II and III support this function.



## fn=65: Function 65 Setting the number of digits of PDF417

### GS ( k pL pH cn fn n

---

<b>[Code]</b>	<1D>H<28>H<6B>H<pL><pH><cn><fn><n>
<b>[Range]</b>	(pL+pH×256)=3 (pL=3, pH=0) cn=48 fn=65 0≤n≤30
<b>[Outline]</b>	<b>[The specification which is common to the model]</b> <ul style="list-style-type: none"><li>• Sets the number of digits of PDF417.</li><li>• With n=0, automatic processing is specified.<ul style="list-style-type: none"><li>* For the number of digits in this case, the number of code words is calculated based on current print area.</li></ul></li><li>• With n≠0, the number of digits of PDF417 data area is designated to n code word.</li></ul>
<b>[Caution]</b>	<b>[The specification which is common to the model]</b> <ul style="list-style-type: none"><li>• Start pattern and stop pattern are not included in the number of digits.</li><li>• Left-step indicator code word and right-step indicator code word are not included in the number of digits.</li></ul>
<b>[Default]</b>	n=0

## fn=66: Function 66 Setting the number of steps of PDF417

### GS ( k pL pH cn fn n

---

<b>[Code]</b>	<1D>H<28>H<6B>H<pL><pH><cn><fn><n>
<b>[Range]</b>	(pL+pH×256)=3 (pL=3, pH=0) cn=48 fn=66 n=0, 3≤n≤90
<b>[Outline]</b>	<b>[The specification which is common to the model]</b> <ul style="list-style-type: none"><li>• Sets the number of steps of PDF417.</li><li>• With n=0, automatic processing is specified.<ul style="list-style-type: none"><li>* The number of steps in this case is calculated based on the number of code words and current print area.</li></ul></li><li>• With n≠0, the number of steps of PDF417 is set to n steps.</li></ul>
<b>[Default]</b>	n=0

**fn=67: Function 67 Setting module width of PDF417**

## **GS ( k pL pH cn fn n**

---

<b>[Code]</b>	<1D>H<28>H<6B>H<pL><pH><cn><fn><n>
<b>[Range]</b>	(pL+pH×256)=3 (pL=3, pH=0) cn=48 fn=67 2≤n≤8
<b>[Outline]</b>	<b>[The specification which is common to the model]</b> <ul style="list-style-type: none"><li>• Sets the width of one module of PDF417 to n dots.</li></ul>
<b>[Default]</b>	n=3

**fn=68: Function 68 Setting the height of step of PDF417**

## **GS ( k pL pH cn fn n**

---

<b>[Code]</b>	<1D>H<28>H<6B>H<pL><pH><cn><fn><n>
<b>[Range]</b>	(pL+pH×256)=3 (pL=3, pH=0) cn=48 fn=68 2≤n≤8
<b>[Outline]</b>	<b>[The specification which is common to the model]</b> <ul style="list-style-type: none"><li>• Sets the height of the step of PDF417 to [Module width (Function 67) x n] .</li></ul>
<b>[Default]</b>	n=3

**fn=69: Function 69 Setting error correction level of PDF417**

**GS ( k pL pH cn fn m n**

**[Code]** <1D>H<28>H<6B>H<pL><pH><cn><fn><m><n>

**[Range]** (pL+pH×256)=4 (pL=4, pH=0)  
 cn=48  
 fn=69  
 m=48, 49  
 48≤n≤56 (when m=48 is specified)  
 1≤n≤40 (when m=49 is specified)

**[Outline]** **[The specification which is common to the model]**

- Sets error correction level of PDF417
- When m=48, set by the level of n.

n	Function	Error Correction Code Words
48	Selects error correction level 0.	2
49	Selects error correction level 1.	4
50	Selects error correction level 2.	8
51	Selects error correction level 3.	16
52	Selects error correction level 4.	32
53	Selects error correction level 5.	64
54	Selects error correction level 6.	128
55	Selects error correction level 7.	256
56	Selects error correction level 8.	512

- When m=49, [set by the ratio (nx10%)] to the number of data code words.
- Calculation result (A) = Value of (number of data code words nx0.1) rounded to the nearest one.

Result (A)	Function	Error Correction Code Words
0 to 3	Selects error correction level 1.	4
4 to 10	Selects error correction level 2.	8
11 to 20	Selects error correction level 3.	16
21 to 45	Selects error correction level 4.	32
46 to 100	Selects error correction level 5.	64
101 to 200	Selects error correction level 6.	128
201 to 400	Selects error correction level 7.	256
401 to	Selects error correction level 8.	512

**[Default]** m=49, n=1

## fn=70: Function 70 Setting Options for PDF417

# GS ( k pL pH cn fn m

---

**[Code]** <1D>H<28>H<6B>H<pL><pH><cn><fn><m>

**[Range]**  $(pL+pH \times 256) = 3$  (pL=3, pH=0)  
cn=48  
fn=70  
m=0, 1

**[Outline]** **[The specification which depend on the model]**

- Specifies or clears the PDF417 option.

m	Function
0	Canceling Processing of simple PDF417
1	Specifying Processing of simple PDF417

**[Caution]** • When cleared with m=0, standard processing for PDF417 is conducted thereafter.

**[Default]** m=0

## fn=80: Function 80 Storing received data to 2D code data storage area

# GS ( k pL pH cn fn m d1...dk

---

**[Code]** <1D>H<28>H<6B>H<pL><pH><cn><fn><m><d1...dk>

**[Range]**  $4 \leq (pL+pH \times 256) \leq 65535$  ( $0 \leq pL \leq 255$ ,  $0 \leq pH \leq 255$ )  
cn=48  
fn=80  
m=48  
 $0 \leq d \leq 255$   
 $k = (pL+pH \times 256) - 3$

**[Outline]** **[The specification which is common to the model]**

- Stores PDF417 2-dimensional code data (d1...dk) to 2-dimensional code data storage area.
- Processes  $[(pL+pH \times 256) - 3]$  of d1 and thereafter as 2-dimensional code data.

**[Sample Program]**

**[Print Results]**

[Refer to Sample Program and Print Results for fn=81: Function181.](#)

## fn=81: Function 81 Printing 2D code data in 2D code data storage area

# GS ( k pL pH cn fn m

---

**[Code]** <1D>H<28>H<6B>H<pL><pH><cn><fn><m>

**[Range]** (pL+pH×256)=3 (pL=3, pH=0)  
cn=48  
fn=81  
m=48

**[Outline]** **[The specification which is common to the model]**  
• Prints PDF417 stored in 2-dimensional code data storage area.

**[Caution]** **[The specification which is common to the model]**  
• Quiet zone (blank area around PDF417) shall be secured by the user.

### **[Sample Program]**

```
LPRINT CHR$(&H1D);"/";"K"; CHR$(10); CHR$(0); CHR$(48); CHR$(80); CHR$(48);  
LPRINT "CITIZEN"  
LPRINT CHR$(&H1D);"/";"K"; CHR$(3); CHR$(0); CHR$(48); CHR$(81); CHR$(48);
```

### **[Print Results]**



**fn=82: Function 82 Sending the size of 2D code data in 2D code data storage area**

# GS ( k pL pH cn fn m

**[Code]** <1D>H<28>H<6B>H<pL><pH><cn><fn><m>

**[Range]** (pL+pH×256)=3 (pL=3,pH=0)  
 cn=48  
 fn=82  
 m=48

**[Outline]** **[The specification which is common to the model]**  
 • Sends the size information when printing 2-dimensional data stored in the 2-dimensional code data storage area.

	Hex	Decimal	Data Size
Header	37H	55	1 byte
Identifier	2FH	47	1byte
Horizontal size	30H to 39H	48 to 57	1 to 5 bytes
Separator	1FH	31	1 byte
Vertical size	30H to 39H	48 to 57	1 to 5 bytes
Separator	1FH	31	1 byte
Fixed value	31H	49	1 byte
Separator	1FH	31	1 byte
Other info	30H or 31H	48 or 49	1 byte
NUL	00H	0	1 byte

- "Horizontal size" and "Vertical size" indicate the number of dots of PDF417.
- Other info indicates whether symbol is printable or not.

Hex	Decimal	Information
30H	48	Printable
31H	49	Not printable

**[Caution]** **[The specification which is common to the model]**  
 • PDF417 is not printed with the processing of this function.  
 • Quiet zone (blank area around PDF417 symbol) is not included in the size information.

**fn=65: Function 165 Specifying QRCode model**

# GS ( k pL pH cn fn n1 n2

---

**[Code]** <1D>H<28>H<6B>H<pL><pH><cn><fn><n1><n2>

**[Range]** (pL+pH×256)=4 (pL=4, pH=0)  
cn=49  
fn=65  
n1=49, 50  
n2=0

**[Outline]** **[The specification which is common to the model]**  
• Specifies QRCode model.

n1	Function
49	Sets model 1.
50	Sets model 2.

**[Default]** n1=50  
n2=0

**fn=67: Function 167 Sets the module width of QRCode**

# GS ( k pL pH cn fn n

---

**[Code]** <1D>H<28>H<6B>H<pL><pH><cn><fn><n>

**[Range]** (pL+pH×256)=3 (pL=3, pH=0)  
cn=49  
fn=67  
1≤n≤16

**[Outline]** **[The specification which is common to the model]**  
• Sets the width of 1 module of QRCode to n dots.

**[Default]** n=3

**fn=69: Function 169 Setting QRCode error correction level**

**GS ( k pL pH cn fn n**

**[Code]** <1D>H<28>H<6B>H<pL><pH><cn><fn><n>

**[Range]**  $(pL+pH \times 256) = 3$  (pL=3, pH=0)  
 cn=49  
 fn=69  
 $48 \leq n \leq 51$

**[Outline]** **[The specification which is common to the model]**  
 • Sets QRCode error correction level.

n	Function	Ref.: Recovery power (%) approximated
48	Selects error correction level L.	7
49	Selects error correction level M.	15
50	Selects error correction level Q.	25
51	Selects error correction level H.	30

**fn=80: Function 180 Storing received data to 2D code data storage area**

**GS ( k pL pH cn fn m d1...dk**

**[Code]** <1D>H<28>H<6B>H<pL><pH><cn><fn><m><d1...dk>

**[Range]**  $4 \leq (pL+pH \times 256) \leq 7092$  ( $0 \leq pL \leq 255$ ,  $0 \leq pH \leq 28$ )  
 cn=49  
 fn=80  
 m=48  
 $0 \leq d \leq 255$   
 $k = (pL+pH \times 256) - 3$

**[Outline]** **[The specification which is common to the model]**  
 • Stores QRCode 2-dimensional code data (d1...dk) to 2-dimensional code data storage area.  
 • Processes  $[(pL+pH \times 256) - 3]$  of d1 and thereafter as 2-dimensional code data.

**[Sample Program]**

**[Print Results]**

[Refer to Sample Program and Print Results for fn=81: Function181.](#)



**fn=81: Function 181 Printing 2D code data in 2D code data storage area**

# **GS ( k pL pH cn fn m**

---

**[Code]** <1D>H<28>H<6B>H<pL><pH><cn><fn><m>

**[Range]** (pL+pH×256)=3 (pL=3, pH=0)  
cn=49  
fn=81  
m=48

**[Outline]** **[The specification which is common to the model]**  
• Prints QRCode data stored in 2-dimensional code data storage area.

**[Caution]** **[The specification which is common to the model]**  
• Quiet zone (blank area around QRCode) shall be secured by the user.

**[Sample Program]**

```
LPRINT CHR$( &H1D );"/";"k"; CHR$(10); CHR$(0); CHR$(49); CHR$(80); CHR$(48);  
LPRINT "CITIZEN"  
LPRINT CHR$( &H1D );"/";"k"; CHR$(3); CHR$(0); CHR$(49); CHR$(81); CHR$(48);
```

**[Print Results]**



**fn=82: Function 182 Sending the size of 2D code data in 2D code data storage area**

# GS ( k pL pH cn fn m

**[Code]** <1D>H<28>H<6B>H<pL><pH><cn><fn><m>

**[Range]** (pL+pH×256)=3(pL=3, pH=0)  
 cn=49  
 fn=82  
 m=48

**[Outline]** **[The specification which is common to the model]**

- Sends the size information when printing 2-dimensional data stored in the 2-dimensional code data storage area.

	Hex	Decimal	Data size
Header	37H	55	1 byte
Identifier	36H	54	1 byte
Horizontal size	30H to 39H	48 to 57	1 to 5 bytes
Separator	1FH	31	1 byte
Vertical size	30H to 39H	48 to 57	1 to 5 bytes
Separator	1FH	31	1 byte
Fixed value	31H	49	1 byte
Separator	1FH	31	1 byte
Other info	30H or 31H	48 or 49	1 byte
NUL	00H	0	1 byte

- “Horizontal size” and “Vertical size” indicate the number of dots of QRCode.
- Other info indicates whether symbol is printable or not.

Hex	Decimal	Information
30H	48	Printable
31H	49	Not printable

**[Caution]** **[The specification which depend on the model]**

- QRCode is not printed with the processing of this function.
- Quiet zone (blank area around QRCode symbol) is not included in the size information.

**fn=67: Function 367 Setting module width of 2D GS1 DataBar**

## **GS ( k pL pH cn fn n**

---

<b>[Code]</b>	<1D>H<28>H<6B>H<pL><pH><cn><fn><n>
<b>[Range]</b>	$(pL + pH \times 256) = 3$ ( $pL = 3$ , $pH = 0$ ) $cn = 51$ $fn = 67$ $2 \leq n \leq 8$
<b>[Outline]</b>	<b>[The specification which is common to the model]</b> <ul style="list-style-type: none"><li>• Sets the width of one module of GS1 DataBar to n dots.</li></ul>
<b>[Default]</b>	$n = 2$

**fn=71: Function 371 Setting maximum width of 2D GS1 DataBar Expanded Stacked**

## **GS ( k pL pH cn fn nL nH**

---

<b>[Code]</b>	<1D>H<28>H<6B>H<pL><pH><cn><fn><nL><nH>
<b>[Range]</b>	$(pL + pH \times 256) = 4$ ( $pL = 4$ , $pH = 0$ ) $cn = 51$ $fn = 71$ $106 \leq (nL + nH \times 256) \leq 39528$
<b>[Outline]</b>	<b>[The specification which is common to the model]</b> <ul style="list-style-type: none"><li>• Sets the maximum width of GS1 DataBar Expanded Stacked to <math>(pL + pH \times 256)</math> dots.</li></ul>
<b>[Default]</b>	$(pL + pH \times 256) = 141$ ( $pL = 141$ , $pH = 0$ )

**fn=80: Function 380 Storing 2D GS1 DataBar data to 2D code data storage area**

# GS ( k pL pH cn fn m n d1 ... dk

**[Code]** <1D>H<28>H<6B>H<pL><pH><cn><fn><m><n><d1...dk>

**[Range]**  $6 \leq (pL + pH \times 256) \leq 259$  ( $0 \leq pL \leq 255$ ,  $pH=0,1$ )  
 $cn=51$   
 $fn=80$   
 $m=48$   
 $n=72,73,76$   
 $k=(pL + pH \times 256) - 4$   
 Range of d is different depending on type of GS1 Databar specified by n.  
 GS1 DataBar Stacked and GS1 DataBar Stacked Omnidirectional are same as GS1 DataBar Omnidirectional.  
 GS1 DataBar Expanded Stacked is same as GS1 DataBar Expanded.

**[Outline]** **[The specification which is common to the model]**  
 • Stores 2-dimensional GS1 DataBar code data (d1...dk) to 2-dimensional code data storage area.

n	Barcode
72	GS1 DataBar Stacked
73	GS1 DataBar Stacked Omnidirectional
76	GS1 DataBar Expanded Stacked

**fn=81: Function 381 Printing 2D GS1 Databar data in 2D code data storage area**

# GS ( k pL pH cn fn m

**[Code]** <1D>H<28>H<6B>H<pL><pH><cn><fn><m>

**[Range]**  $(pL + pH \times 256) = 3$  ( $pL=3$ ,  $pH=0$ )  
 $cn=51$   
 $fn=81$   
 $m=48$

**[Outline]** **[The specification which is common to the model]**  
 • Prints GS1 DataBar code data stored in 2-dimensional code data storage area.

**fn=82: Function 382 Sending the size of 2D code data in 2D code data storage area**

# GS ( k pL pH cn fn m

**[Code]** <1D>H<28>H<6B>H<pL><pH><cn><fn><m>

**[Range]** (pL+pH×256)=3 (pL=3、pH=0)  
 cn=51  
 fn=82  
 m=48

**[Outline]** **[The specification which is common to the model]**

- Sends the size information when printing 2-dimensional data stored in the 2-dimensional code data storage area.

	Hex	Decimal	Data size
Header	37H	55	1 byte
Identifier	4FH	79	1 byte
Horizontal size	30H - 39H	48 - 57	1 - 5 bytes
Separator	1FH	31	1 byte
Vertical size	30H - 39H	48 - 57	1 - 5 bytes
Separator	1FH	31	1 byte
Fixed value	31H	49	1 byte
Separator	1FH	31	1 byte
Other info	30H or 31H	48 or 49	1byte
NUL	00H	0	1 byte

- “Horizontal size” and “Vertical size” indicate the number of dots of GS1 DataBar.
- Other info indicates whether symbol is printable or not.

Other info	Hex	Decimal	Information
“0”	30H	48	Printable
“1”	31H	49	Not printable

## 2.2.18 Presenter/Bezel Control Commands (PMU2xxxIII only)

### GS R 0

Support model	CT-S280	CT-S300	CT-S2000	CT-S4000	BD2-2220	PMU series
	CT-S281	CT-S310	CT-S801/851	CT-S601/651	CT-P29x series	CT-S310 II

- [Function]** Retracting receipt immediately
- [Code]** <1D>H<52>H<30>H
- [Outline]** If the presenter sensor detects paper presence, printer feed the paper to the direction set by MSW11-3 (Retract direction) till the sensor detects no paper.
- [Caution]**
- This command is valid only for PMU2300III.
  - This command is ignored with the setting of MSW11-1=OFF (Presenter = Invalid) or MSW11-2=OFF (Retract function = Invalid).
  - If the printer receives this command before the time of auto receipt retraction, (default = 5 seconds), printer retract the receipt immediately.

### GS R 1

Support model	CT-S280	CT-S300	CT-S2000	CT-S4000	BD2-2220	PMU series
	CT-S281	CT-S310	CT-S801/851	CT-S601/651	CT-P29x series	CT-S310 II

- [Function]** Setting timer for auto receipt retraction
- [Code]** <1D>H<52>H<31>H<n>
- [Range]** 0≤n≤9
- [Outline]** Printer automatically retracts the receipt in specified time from receipt ejection.. The time to start retraction is specified by n x 1 seconds.  
If n = 0 is set, automatic retraction does not occur and only GS R 0 command can retract the receipt timer.
- [Caution]**
- This command is valid only for PMU2300III.
  - This command is ignored with the setting of MSW11-1=OFF (Presenter = Invalid) or MSW11-2=OFF (Retract function = Invalid).
  - Default value of auto retraction can be changed by < GS ( E > command.
- [Default]** n=5 (5 seconds)

**[Sample Program]**

```
LPRINT CHR$(&H1D); CHR$(&H52); CHR$(&H31); CHR$(1);  
...Timer for automatic retraction is set for 1 sec.
```

# GS R 2 n t1 t2

Support model	CT-S280	CT-S300	CT-S2000	CT-S4000	BD2-2220	PMU series
	CT-S281	CT-S310	CT-S801/851	CT-S601/651	CT-P29x series	CT-S310 II

**[Function]** Controlling bezel LED

**[Code]** <1D>H<52>H<32>H<n>H<t1>H<t2>

**[Range]**  $0 \leq n \leq 2, 48 \leq n \leq 50$   
 $0, 2 \leq t1 \leq 255, 0, 2 \leq t2 \leq 255$

**[Outline]** This command controls Bezel LED.

"n" specifies the mode of Bezel LED.

n	Bezel LED mode
0,48	OFF
1,49	ON
2,50	Blinking

t1: ON time of Bezel LED control

$2 \leq t1 \leq 255$ : ON time =  $t1 \times 100\text{ms}$

t1 = 0: ON time = Default (5 x 100ms)

t2: OFF time of Bezel LED control

$2 \leq t2 \leq 255$ : OFF time =  $t2 \times 100\text{ms}$

t2 = 0: OFF time = Default (5 x 100ms)

If "n" is set for OFF or ON, OFF/ON time is  $t1 + t2$ .

If "n" is set for Blinking, LED blinks twice with specified ON/OFF time.

**[Caution]** This command is valid only with setting of MSW12-1 = ON (Bezel function = Valid)  
 This command is valid even with the setting of MSW12-2 = OFF (Bezel LED control = Invalid)  
 This command has higher priority against the setting of various bezel LED control by  
 GS + ( + E fn=5 a=131 – 136 command.

**[Default]** t1 = 5(500ms)  
 t2 = 5(500ms)

**[Sample Program]**

```
LPRINT CHR$(&H1D); CHR$(&H52); CHR$(&H32); CHR$(2); CHR$(10); CHR$(10);
```

... On time of LED blinking is set for 1 sec and Off time of LED blinking is set for 1 sec.

# GS S

Support model	CT-S280	CT-S300	CT-S2000	CT-S4000	BD2-2220	PMU series
	CT-S281	CT-S310	CT-S801/851	CT-S601/651	CT-P29x series	CT-S310 II

**[Function]** Detecting next black mark

**[Code]** <1D>H<53>H

**[Outline]** This command prints the data in the printer buffer, feeds the paper to search for the next Black mark and stops paper feeding by detecting the black mark.

**[Caution]**

- This command is ignored with the setting of MSW3-4 = OFF (Thermal paper is selected)
- When printer receives this command during searching black mark, printer searches for 2<sup>nd</sup> black mark.
- At power on, printer searches for the black mark, cuts the paper and ejects it.
- If any black mark cannot be detected within 18 inch paper feeding,, printer shows black mark error , outputs BUSY and FAULT or DTR signal , cuts the paper and ejects the paper.



## 2.2.19 Other Commands

# DLE ENQ n

Support model	CT-S280	CT-S300	CT-S2000	CT-S4000	BD2-2220	PMU series
	CT-S281	CT-S310	CT-S801/851	CT-S601/651	CT-P29x series	CT-S310 II

**[Function]** Real-time request to printer

**[Code]** <10>H<05>H<n>

**[Range]**  $0 \leq n \leq 2$

**[Outline]** **[The specification which is common to the model]**

- The printer responds in real-time to the request that the host specifies with number "n".

n	Function
0	At the setting of execution of GS ^ by the FEED switch, the same processing as that pressing the FEED switch once is carried out.
1	After recovering from an error, the printer resumes printing from the beginning of the line where the error occurred.
2	The printer clears the receive buffer and the print buffer, and then recovers from the error.

**[Caution]** **[The specification which is common to the model]**

- (n = 1) or (n = 2) shall be used after removing the error.
- If another data string of <10>H<05>H<n> ( $1 \leq n \leq 2$ ) is received, the printer acts the same way as with this command. Therefore, the user should be reminded of this fact.

[Example 1]

Suppose a command "ESC \* m nL nH [d1 ... dk]", where d1 = <10>H, d2 = <05>H, d3 = <01>H.

- The DLE EOT n command cannot be interleaved into the code string of another command consisting of 2 bytes or more.

[Example 2]

If the printer sends DLE ENQ n after the host has sent up to ESC 3 in its attempt to send ESC 3 n, the printer handles the ESC 3 as ESC 3 <10>H. Thus, the user should be cautious.

- This command is ignored during transmission of block data.

**[See Also]** [DLE EOT](#)

# DLE DC4 fn m t (Specification of fn = 1)

Support model	CT-S280	CT-S300	CT-S2000	CT-S4000	BD2-2220	PMU series
	CT-S281	CT-S310	CT-S801/851	CT-S601/651	CT-P29x series	CT-S310 II

**[Function]** Outputting specified pulse in real-time

**[Code]** <10>H<14>H<fn><m><t>

**[Range]** fn=1,  
m=0, 1  
1 ≤ t ≤ 8

**[Outline]** **[The specification which is common to the model]**  
 • A signal specified with "Y" is output to the connector pin specified with "m".

m	Connector Pin
0	Pin No. 2 of drawer kick-out connector
1	Pin No. 5 of drawer kick-out connector

- Set the ON time/OFF time to t x100 ms, respectively.

**[Caution]** **[The specification which is common to the model]**

- When receiving a code row coinciding with the code configuring this command, the same operation as this command takes place and attention by the user is required.  
Example: When corresponding code row is present in bit image data.
- This command must not be used between other command code rows.  
Example: This command is used in the bit image data.
- This command is ignored under the following conditions.
  - During sending block data
  - During output of signal to drawer kick connector
  - During occurrence of error

**[See Also]** [ESC.p](#)

# DLE DC4 fn d1...d7 (Specification of fn = 8)

Support model	CT-S280	CT-S300	CT-S2000	CT-S4000	BD2-2220	PMU series
	CT-S281	CT-S310	CT-S801/851	CT-S601/651	CT-P29x series	CT-S310 II

**[Function]** Buffer clear

**[Code]** <10>H<14>H<fn><d1> ...<d7>

**[Range]** fn=8, d1=1, d2=3, d3=20, d4=1, d5=6, d6=2, d7=8

**[Outline]** **[The specification which is common to the model]**

- Erases all data in receiving buffer or print buffer.
- Sends the following 3-byte data group.

	Hex.	Decimal	No. of Data
Header	37H	55	1 byte
Identifier	25H	37	1 byte
NULL	00H	0	1 byte

- Enters the state of selecting STANDARD MODE.

**[Caution]** **[The specification which is common to the model]**

- When receiving a code row coinciding with the code configuring this command, the same operation as this command takes place and attention by the user is required.  
Example: When corresponding code row is present in bit image data.
- This command must not be used between other command code rows.  
Example: This command is used in the bit image data.
- This command is ignored under the following conditions.
- During sending block data

# ESC = n

Support model	CT-S280	CT-S300	CT-S2000	CT-S4000	BD2-2220	PMU series
	CT-S281	CT-S310	CT-S801/851	CT-S601/651	CT-P29x series	CT-S310 II

**[Function]** Data input control

**[Code]** <1B>H<3D>H<n>

**[Range]** 0≤n≤255

**[Outline]** **[The specification which is common to the model]**

- Selecting equipment for which data input from the host is valid.
- Each bit of "n" indicates as follows.
- When the printer has not been selected, this printer abandons all the received data until it is selected by this command.

Bit	Equipment	Value	
		0	1
0	Printer	Invalid	Valid
1	Not defined	—	—
2	Not defined	—	—
3	Not defined	—	—
4	Not defined	—	—
5	Not defined	—	—
6	Not defined	—	—
7	Not defined	—	—

**[Caution]** **[The specification which is common to the model]**

- Even when the printer has not been selected, it can become BUSY state through printer operation.
- When the printer is deselected, this printer discards all the data until it is selected with this command. (Except DLE EOT, DLE ENQ, and DLE DC4)

**[Default]** n=1

# ESC @

Support model	CT-S280	CT-S300	CT-S2000	CT-S4000	BD2-2220	PMU series
	CT-S281	CT-S310	CT-S801/851	CT-S601/651	CT-P29x series	CT-S310 II

**[Function]** Initializing the printer

**[Code]** <1B>H<40>H

**[Outline]** **[The specification which is common to the model]**  
• Clears data stored in the print buffer and brings various settings to the initial state (Default state).

**[Caution]** **[The specification which is common to the model]**  
• The settings of DIP switches are not read again.  
• Data inside the internal input buffer is not cleared.  
• Macro definitions are not cleared.  
• NV bit image definitions are not cleared.  
• Data in the user NV memory is not cleared.

**[Sample Program]**  
LPRINT CHR\$(&H1B);"!"; CHR\$(&H30);  
LPRINT CHR\$(&H1B);"V"; CHR\$(1);  
LPRINT "AAA"; CHR\$(&HA);  
LPRINT CHR\$(&H1B);"@";  
LPRINT "AAA"; CHR\$(&HA);

**[Print Results]**

▷▷▷

AAA

Each setting has been initialized by this command.

# ESC L

Support model	CT-S280	CT-S300	CT-S2000	CT-S4000	BD2-2220	PMU series
	CT-S281	CT-S310	CT-S801/851	CT-S601/651	CT-P29x series	CT-S310 II

**[Function]** Selecting PAGE MODE

**[Code]** <1B>H<4C>H

**[Outline]** **[The specification which is common to the model]**

- Switches from STANDARD MODE to PAGE MODE.

**[Caution]** **[The specification which is common to the model]**

- This command is only effective if it entered at the beginning of a line.
- This command is not effective if it is entered when in PAGE MODE.
- STANDARD MODE is restored when printing specified by FF is finished or when ESC S is issued.
- The character mapping start position will be the point specified by ESC T in the print area specified by ESC W.
- The commands listed below, which have separate settings for PAGE MODE and STANDARD MODE, are changed to the settings for PAGE MODE use.
  - (1) Spacing setting: ESC SP, FS S
  - (2) Line feed width setting: ESC 2, ESC 3
- The following commands are valid only in PAGE MODE.
  - (1) ESC V Specifying/canceling 90°-right-turned characters.
  - (2) ESC a Aligning the characters.
  - (3) ESC { Specifying/canceling the inverted characters.
  - (4) GS L Setting the left margin.
  - (5) GS W Setting the print area width.
- The following commands are disabled in PAGE MODE.
  - (1) GS ( A Executes test printing.
  - (2) FS p Prints NV memory bit image.
  - (3) FS q Defines NV memory bit image.
  - (4) GS v 0 Prints raster bit image.
- ESC @ restores STANDARD MODE.

**[See Also]** [Appendix 5.1.4 "Example of using PAGE MODE"](#)  
[FF](#), [CAN](#), [ESC FF](#), [ESC S](#), [ESC T](#), [ESC W](#), [GS W](#), [GS \](#)

# ESC S

Support model	CT-S280	CT-S300	CT-S2000	CT-S4000	BD2-2220	PMU series
	CT-S281	CT-S310	CT-S801/851	CT-S601/651	CT-P29x series	CT-S310 II

**[Function]** Selecting STANDARD MODE

**[Code]** <1B>H<53>H

**[Outline]** **[The specification which is common to the model]**

- Switches from PAGE MODE to STANDARD MODE.

**[Caution]** **[The specification which is common to the model]**

- This command is only effective if it is entered when in PAGE MODE.
- Any data mapped in PAGE MODE is erased.
- After this command is executed, the beginning of the line is taken as the next print start position.
- The print area defined by ESC W is initialized.
- The commands listed below, which have separate settings for STANDARD MODE and PAGE MODE, are changed to the settings for STANDARD MODE use.
  - (1) Spacing setting: ESC SP, FS S
  - (2) Line feed width setting: ESC 2, ESC 3
- The following commands are valid only in setting in STANDARD MODE.
  - (1) ESC W Sets the space amount for setting print area in PAGE MODE.
  - (2) ESC T Selects the printing direction of character in PAGE MODE.
  - (3) GS \$ Sets the absolute position of character vertical direction in PAGE MODE.
- STANDARD MODE is selected when the printer is turned on or reset, or when ESC @ is executed.

**[See Also]** [FF](#), [ESC FF](#), [ESCL](#)

# ESC p m n1 n2

Support model	CT-S280	CT-S300	CT-S2000	CT-S4000	BD2-2220	PMU series
	CT-S281	CT-S310	CT-S801/851	CT-S601/651	CT-P29x series	CT-S310 II

**[Function]** Generating the specified pulses

**[Code]** <1B>H<70>H<m><n1><n2>

**[Range]** m=0, 1, 48, 49  
0<n1≤n2≤255

**[Outline]** **[The specification which is common to the model]**

- The signals specified by "n1" and "n2" are output to the connector pin specified by "m".
- "m" has the followings.

m	Connector Pin
0, 48	Drawer kick-out pin No. 2
1, 49	Drawer kick-out pin No. 5

- The ON time is n1 x2 ms, and OFF time n2 x2 ms.

**[Caution]** **[The specification which is common to the model]**

- When "m" is beyond a definition range, no signal is output, discarding "n1" and "n2".
- The drawer drive duty must be within the following range:

$$\frac{\text{ON time}}{\text{ON time} + \text{OFF time}} \leq 0.2$$

(The OFF time should be 4 times or more longer than the ON time.)

**[Sample Program]**

```
LPRINT CHR$(&H1B) + "p"
LPRINT CHR$(0);           — Selects pin No. 2.
LPRINT CHR$(5);           — Sets ON time to 10 ms
LPRINT CHR$(50);          — Sets OFF time to 100 ms
```



# GS ( A pL pH n m

Support model	CT-S280	CT-S300	CT-S2000	CT-S4000	BD2-2220	PMU series
	CT-S281	CT-S310	CT-S801/851	CT-S601/651	CT-P29x series	CT-S310 II

**[Function]** Execution of test printing

**[Code]** <1D>H<28>H<41>H<pL><pH><n><m>

**[Range]**  $(pL+(pH \times 256))=2$  ( $pL=2, pH=0$ )  
 $0 \leq n \leq 2, 48 \leq n \leq 50$   
 $1 \leq m \leq 4, 49 \leq m \leq 52$

**[Outline]** **[The specification which is common to the model]**

- Specified test printing will be executed.
- pL, pH will specify the number of subsequent parameters by  $(pL+(pH \times 256))$  bytes.
- "n" will specify the paper for test printing in the following table.

n	Category of Paper
0, 48	Basic paper (Paper rolls)
1, 49 2, 50	Paper rolls

- "m" will specify the category of test printing in the following table.

m	Category of Test Printing
1, 49	Hexadecimal dump
2, 50	Printer's status printing
3, 51	Rolling pattern printing

**[The specification which depend on the model]**

**PMU2XXXII/PMU2300III/CT-P29x series**

m	Category of Test Printing
1, 49	Hexadecimal dump
2, 50	Printer's status printing
3, 51	Rolling pattern printing
4, 52	Memory Switch sitting printing

**[Caution]** **[The specification which is common to the model]**

- This command is only valid when processed at the head of a line during the STANDARD MODE.
- The command will be ignored in PAGE MODE.
- During macro definition, if this command is processed, the macro definition is suspended, and the command starts being processed.
- Printer will reset its hard disk after finishing test printing. Therefore, the printer makes download characters, bit map images and macros undefined, clears the reception buffer/print buffer, and returns the various settings to defaults. At this time, the DIP switches are read again.
- Paper cutting is performed at the end of test printing.  
 \*Functions with cutter-mounted model and when cutter is set to be enabled.
- Printer will be BUSY when the processing of the command starts.

# GS I n

Support model	CT-S280	CT-S300	CT-S2000	CT-S4000	BD2-2220	PMU series
	CT-S281	CT-S310	CT-S801/851	CT-S601/651	CT-P29x series	CT-S310 II

**[Function]** Sending the printer ID

**[Code]** <1D>H<49>H<n>

**[Range]** **CT-S280/BD2-2220**  
 $1 \leq n \leq 3, 49 \leq n \leq 51, 65 \leq n \leq 67, n=69, 112$   
**CT-S281/CT-S300/CT-S310/CT-S2000/CT-S4000/CT-S801/CT-S851**  
**CT-S601/CT-S651/PMU series/CT-P29x series/CT-S310II**  
 $1 \leq n \leq 4, 49 \leq n \leq 52, 65 \leq n \leq 67, n=69, 112$

**[Outline]** **[The specification which is common to the model]**

- Sends the specified printer ID.

**[Caution]** **[The specification which is common to the model]**

- Under DTR/DSR control, the printer sends the printer ID after verifying that the host is ready to receive.
- If the host is not ready to receive, the printer waits for the host to become ready to receive.
- Under XON/XOFF control, the printer sends the printer ID without checking whether or not the host is ready to receive.
- Because this command is executed when data is mapped in the receive buffer, there may be a delay between command receiving and printer ID sending depending on the condition of the receive buffer.
- If ASB (Automatic Status Back) is enabled by GS a, the host must discriminate between the printer ID due to this command and the status due to ASB.

**[The specification which depend on the model]**

**CT-S281/CT-S300/CT-S310/CT-S2000/CT-S4000/CT-S801/CT-S851**  
**CT-S601/CT-S651/PMU series**

- Sending the Black mark length is valid only when Black mark paper is selected.

**CT-S280**

n	Type of Printer ID	Specification	Value (Hex.)
1, 49	Model ID	CT-S280	31H
2, 50	Type ID	Refer to table "Type ID" below	
3, 51	ROM version ID	Differs by ROM version.	

- Type ID If n=2, 50 is specified:

Bit	Meaning	Hex.	Decimal
0	Not equipped for 2 byte code support	00H	0
	Equipped for 2 byte code support	01H	1
1	Fixed	00H	0
2	Reserved	00H	0
3	Reserved	00H	0
4	Fixed	00H	0
5	Reserved	00H	0
6	Reserved	00H	0
7	Fixed	00H	0

- Printer information configuration on and after transmitted n=65 is shown below.

n	Kind of Printer Information	Information
65	Firmware version	Differs by firmware version.
66	Manufacturer name	CITIZEN
67	Model name	CT-S280
69	Kinds of multi-language fonts	Japanese Kanji specifications: KANJI JAPANESE
112	State of DSW	Refer to table "DSW" below (only serial model)

- Sends printer information specified by n=65 or more.

	Hex.	Number of Data
Header	5FH	1
Data	20H to 7FH	Subject to item to be responded
NULL	00H	1

- DSW If n=112 is specified:

Bit	Function	Hex.	Decimal
0	Dip switch [DSW5] is OFF	00H	0
	Dip switch [DSW5] is ON	01H	1
1	Dip switch [DSW6] is OFF	00H	0
	Dip switch [DSW6] is ON	02H	2
2	Dip switch [DSW7] is OFF	00H	0
	Dip switch [DSW7] is ON	04H	4
3	Dip switch [DSW8] is OFF	00H	0
	Dip switch [DSW8] is ON	08H	8
4	Reserved	00H	0
5	Reserved	00H	0
6	Fixed	40H	64
7	Fixed	00H	0

\*only serial model

**CT-S281**

n	Type of Printer ID	Specification	Value (Hex.)
1, 49	Model ID	CT-S281	31H
2, 50	Type ID	Refer to table "Type ID" below	
3, 51	ROM version ID	Differs by ROM version.	

- Type ID If n=2, 50 is specified:

Bit	Meaning	Hex.	Decimal
0	Not equipped for 2 byte code support	00H	0
	Equipped for 2 byte code support	01H	1
1	Fixed	00H	0
2	Thermal paper	00H	0
	Black mark paper/ Label paper (when Black mark paper/ Label paper is selected)	04H	4
3	Reserved	00H	0
4	Fixed	00H	0
5	Reserved	00H	0
6	Reserved	00H	0
7	Fixed	00H	0

n = 4, 52 specified (only for B.M/Label specs)

The Black mark length/label gap length and mark interval/label length currently used are returned in 4-byte code. All fractional parts in millimeters are rounded off.

Byte 1 + Byte 2 x256 = Black mark interval/label length

Byte 3 + Byte 4 x256 = Black mark length mm/label gap length

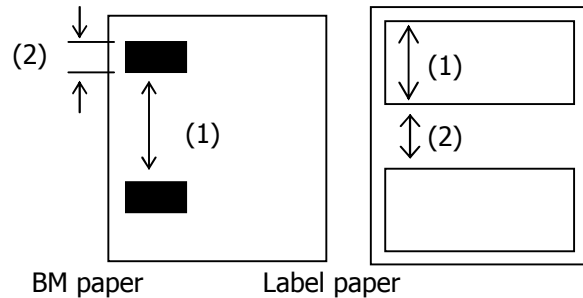

- Printer information configuration on and after transmitted n=65 is shown below.

n	Kind of Printer Information	Information
65	Firmware version	Differs by firmware version.
66	Manufacturer name	CITIZEN
67	Model name	CT-S281
69	Kinds of multi-language fonts	Japanese Kanji specifications: KANJI JAPANESE
112	State of DSW	Refer to table "DSW" below (only serial model)

- DSW If n = 112 is specified:

Bit	Function	Hex.	Decimal
0	Dip switch [DSW8] is OFF	00H	0
	Dip switch [DSW8] is ON	01H	1
1	Dip switch [DSW7] is OFF	00H	0
	Dip switch [DSW7] is ON	02H	2
2	Dip switch [DSW6] is OFF	00H	0
	Dip switch [DSW6] is ON	04H	4
3	Dip switch [DSW5] is OFF	00H	0
	Dip switch [DSW5] is ON	08H	8
4	Dip switch [DSW4] is OFF	00H	0
	Dip switch [DSW4] is ON	10H	16
5	Dip switch [DSW3] is OFF	00H	0
	Dip switch [DSW3] is ON	20H	32
6	Dip switch [DSW2] is OFF	00H	0
	Dip switch [DSW2] is ON	40H	64
7	Dip switch [DSW1] is OFF	00H	0
	Dip switch [DSW1] is ON	80H	128

\*only serial model

### CT-S300/CT-S310

n	Type of Printer ID	Specification	Value (Hex.)
1, 49	Model ID	CT-S300,CT-S310	35H
2, 50	Type ID	Refer to table "Type ID" below	
3, 51	ROM version ID	Differs by ROM version.	
4, 52	Black mark Length	Depends on Black mark paper (mm)	

- Type ID If n=2, 50 is specified:

Bit	Meaning	Hex.	Decimal
0	Equipped for 2 byte code support	01H	1
1	Equipped with auto cutter	02H	2
2	Thermal paper	00H	0
	Black mark paper (when Black mark paper is selected)	04H	4
3	Undefined	--	--
4	Unused	00H	0
5	Undefined	--	--
6	Undefined	--	--
7	Unused	00H	0

n = 4, 52 specified (only for B.M specs)

The Black mark length and mark interval currently used are returned in 4-byte code. All fractional parts in millimeters are rounded off.

Byte 1 + Byte 2 x256 = Black mark interval

Byte 3 + Byte 4 x256 = Black mark length mm

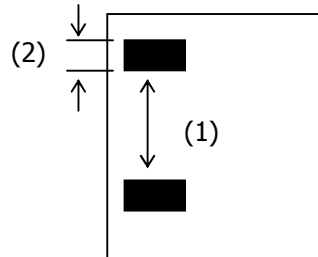

Black mark paper

- Printer information configuration on and after transmitted n=65 is shown below.

n	Kind of Printer Information	Information
65	Firmware version	Differs by firmware version.
66	Manufacturer name	CBM,CITIZEN
67	Model name	CT-S300, CT-S310
69	Kinds of multi-language fonts	Japanese Kanji specifications: KANJI JAPANESE
		Hangul specification: KOREA Chinese specifications: CHINA GB18030
112	State of DSW	Refer to table "DSW" below (only serial model)

- Sends printer information specified by n=65 or more.

	Hex.	Number of Data
Header	5FH	1
Data	20H to 7FH	Subject to item to be responded
NULL	00H	1

- DSW If n = 112 is specified:

Bit	Function	Hex.	Decimal
0	Dip switch [DSW5] is OFF	00H	0
	Dip switch [DSW5] is ON	01H	1
1	Dip switch [DSW6] is OFF	00H	0
	Dip switch [DSW6] is ON	02H	2
2	Dip switch [DSW7] is OFF	00H	0
	Dip switch [DSW7] is ON	04H	4
3	Dip switch [DSW8] is OFF	00H	0
	Dip switch [DSW8] is ON	08H	8
4	Reserved	00H	0
5	Reserved	00H	0
6	Fixed	40H	64
7	Fixed	00H	0

\*only serial model

## CT-S310II

n	Type of Printer ID	Specification	Value (Hex.)
1, 49	Model ID	CT-S310II	3DH
2, 50	Type ID	Refer to table "Type ID" below	
3, 51	ROM version ID	Differs by ROM version.	

- Type ID If n=2, 50 is specified:

Bit	Meaning	Hex.	Decimal
0	Equipped for 2 byte code support	01H	1
1	Equipped with auto cutter	02H	2
2	Reserved	00H	0
3	Undefined	--	--
4	Unused	00H	0
5	Undefined	--	--
6	Undefined	--	--
7	Unused	00H	0

- Printer information configuration on and after transmitted n=65 is shown below.

n	Kind of Printer Information	Information
65	Firmware version	Differs by firmware version.
66	Manufacturer name	CITIZEN
67	Model name	CT-S310II
69	Kinds of multi-language fonts	Japanese Kanji specifications: KANJI JAPANESE Hangul specification: KOREA Chinese specifications: CHINA GB18030
112	State of DSW	Refer to table "DSW" below (only serial model)

- Sends printer information specified by n=65 or more.

	Hex.	Number of Data
Header	5FH	1
Data	20H to 7FH	Subject to item to be responded
NULL	00H	1

- DSW If n = 112 is specified:

Bit	Function	Hex.	Decimal
0	Dip switch [DSW5] is OFF	00H	0
	Dip switch [DSW5] is ON	01H	1
1	Dip switch [DSW6] is OFF	00H	0
	Dip switch [DSW6] is ON	02H	2
2	Dip switch [DSW7] is OFF	00H	0
	Dip switch [DSW7] is ON	04H	4
3	Dip switch [DSW8] is OFF	00H	0
	Dip switch [DSW8] is ON	08H	8
4	Reserved	00H	0
5	Reserved	00H	0
6	Fixed	40H	64
7	Fixed	00H	0

\*only serial model

## CT-S2000

n	Type of Printer ID	Specification	Value (Hex.)
1, 49	Model ID	CT-S2000	51H
2, 50	Type ID	Refer to table "Type ID" below	
3, 51	ROM version ID	Differs by ROM version.	
4, 52	Black mark/ Label Length	Depends on Black mark paper/ Label paper (mm)	

- Type ID If n=2, 50 is specified:

Bit	Meaning	Hex.	Decimal
0	Equipped for 2 byte code support	01H	1
1	Equipped with auto cutter	02H	2
2	Thermal paper	00H	0
	Black mark paper/ Label paper (when Black mark paper/ Label paper is selected)	04H	4
3	Undefined	--	--
4	Unused	00H	0
5	Undefined	--	--
6	Undefined	--	--
7	Unused	00H	0

n = 4, 52 specified (only for B.M/Label specs)

The Black mark length/label gap length and mark interval/label length currently used are returned in 4-byte code. All fractional parts in millimeters are rounded off.

Byte 1 + Byte 2 x256 = Black mark interval/label length

Byte 3 + Byte 4 x256 = Black mark length mm/label gap length

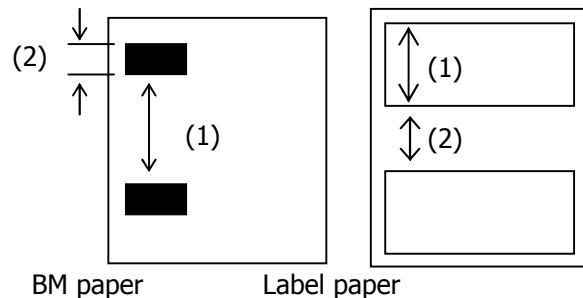

- Printer information configuration on and after transmitted n=65 is shown below.

n	Kind of Printer Information	Information
65	Firmware version	Differs by firmware version.
66	Manufacturer name	CITIZEN
67	Model name	CT-S2000
69	Kinds of multi-language fonts	Japanese Kanji specifications: KANJI JAPANESE
		Hangul specification: KOREA Chinese specifications: CHINA GB18030
112	State of DSW	Refer to table "DSW" below (only serial model)

- Sends printer information specified by n=65 or more.

	Hex.	Number of Data
Header	5FH	1
Data	20H to 7FH	Subject to item to be responded
NULL	00H	1

- DSW If n=112 is specified:

Bit	Function	Hex.	Decimal
0	Dip switch [DSW5] is OFF	00H	0
	Dip switch [DSW5] is ON	01H	1
1	Dip switch [DSW6] is OFF	00H	0
	Dip switch [DSW6] is ON	02H	2
2	Dip switch [DSW7] is OFF	00H	0
	Dip switch [DSW7] is ON	04H	4
3	Dip switch [DSW8] is OFF	00H	0
	Dip switch [DSW8] is ON	08H	8
4	Reserved	00H	0
5	Reserved	00H	0
6	Fixed	40H	64
7	Fixed	00H	0

\*only serial model

**CT-S4000**

n	Type of Printer ID	Specification	Value (Hex.)
1, 49	Model ID	CT-S4000	55H
2, 50	Type ID	Refer to table "Type ID" below	
3, 51	ROM version ID	Differs by ROM version.	
4, 52	Black mark/ Label Length	Depends on Black mark paper/ Label paper (mm)	

- Type ID If n=2, 50 is specified:

Bit	Meaning	Hex.	Decimal
0	Equipped for 2 byte code support	01H	1
1	Equipped with auto cutter	02H	2
2	Thermal paper	00H	0
	Black mark paper/ Label paper (when Black mark paper/ Label paper is selected)	04H	4
3	Undefined	--	--
4	Unused	00H	0
5	Undefined	--	--
6	Undefined	--	--
7	Unused	00H	0

n = 4, 52 specified (only for B.M/Label specs)

The Black mark length/label gap length and mark interval/label length currently used are returned in 4-byte code. All fractional parts in millimeters are rounded off.

Byte 1 + Byte 2 x256 = Black mark interval/label length

Byte 3 + Byte 4 x256 = Black mark length mm/label gap length

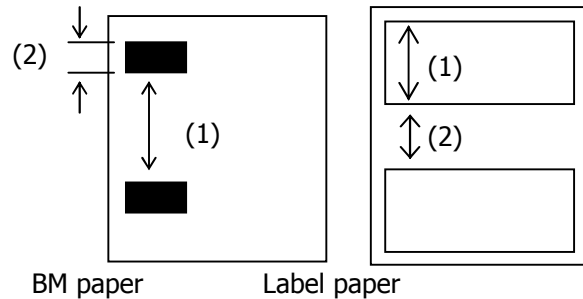

- Printer information configuration on and after transmitted n=65 is shown below.

n	Kind of Printer Information	Information
65	Firmware version	Differs by firmware version.
66	Manufacturer name	CITIZEN
67	Model name	CT-S4000
69	Kinds of multi-language fonts	Japanese Kanji specifications: KANJI JAPANESE
		Hangul specification: KOREA Chinese specifications: CHINA GB18030
112	State of DSW	Refer to table "DSW" below (only serial model)

- Sends printer information specified by n=65 or more.

	Hex.	Number of Data
Header	5FH	1
Data	20H to 7FH	Subject to item to be responded
NULL	00H	1

- DSW If n=112 is specified:

Bit	Function	Hex.	Decimal
0	Dip switch [DSW5] is OFF	00H	0
	Dip switch [DSW5] is ON	01H	1
1	Dip switch [DSW6] is OFF	00H	0
	Dip switch [DSW6] is ON	02H	2
2	Dip switch [DSW7] is OFF	00H	0
	Dip switch [DSW7] is ON	04H	4
3	Dip switch [DSW8] is OFF	00H	0
	Dip switch [DSW8] is ON	08H	8
4	Reserved	00H	0
5	Reserved	00H	0
6	Fixed	40H	64
7	Fixed	00H	0

\*only serial model



**CT-S801/CT-S851/CT-S601/CT-S651**

n	Type of Printer ID	Specification	Value (Hex.)
1, 49	Model ID	CT-S801/851	5DH
		CT-S601/651	3DH
2, 50	Type ID	Refer to table "Type ID" below	
3, 51	ROM version ID	Differs by ROM version.	
4, 52	Black mark/ Label Length	Depends on Black mark paper/ Label paper (mm)	

- Type ID If n=2, 50 is specified:

Bit	Meaning	Hex.	Decimal
0	Equipped for 2 byte code support	01H	1
1	Equipped with auto cutter	02H	2
2	Thermal paper	00H	0
	Black mark paper/ Label paper (when Black mark paper/ Label paper is selected)	04H	4
3	Undefined	--	--
4	Unused	00H	0
5	Undefined	--	--
6	Undefined	--	--
7	Unused	00H	0

n = 4, 52 specified (only for B.M/Label specs)

The Black mark length/label gap length and mark interval/label length currently used are returned in 4-byte code. All fractional parts in millimeters are rounded off.

Byte 1 + Byte 2 x256 = Black mark interval

Byte 3 + Byte 4 x256 = Black mark length mm

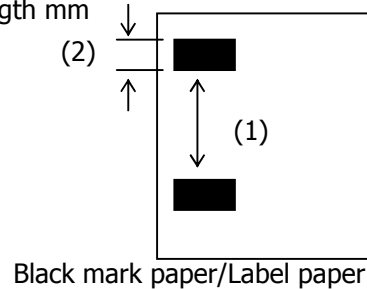

- Printer information configuration on and after transmitted n=65 is shown below.

n	Kind of Printer Information	Information
65	Firmware version	Differs by firmware version.
66	Manufacturer name	CITIZEN
67	Model name	CT-S801
		CT-S851
		CT-S601
		CT-S651
69	Kinds of multi-language fonts	Japanese Kanji specifications: KANJI KANJI JAPANESE Hangul specification: KOREA Chinese specifications: CHINA GB18030
112	State of DSW	Refer to table "DSW" below (only serial model)

- Sends printer information specified by n=65 or more.

	Hex.	Number of Data
Header	5FH	1
Data	20H to 7FH	Subject to item to be responded
NULL	00H	1

- DSW If n=112 is specified:

Bit	Function	Hex.	Decimal
0	Dip switch [DSW5] is OFF	00H	0
	Dip switch [DSW5] is ON	01H	1
1	Dip switch [DSW6] is OFF	00H	0
	Dip switch [DSW6] is ON	02H	2
2	Dip switch [DSW7] is OFF	00H	0
	Dip switch [DSW7] is ON	04H	4
3	Dip switch [DSW8] is OFF	00H	0
	Dip switch [DSW8] is ON	08H	8
4	Reserved	00H	0
5	Reserved	00H	0
6	Fixed	40H	64
7	Fixed	00H	0

\*only serial model

**BD2-2220**

n	Type of Printer ID	Specification	Value (Hex.)
1, 49	Model ID	BD2-2220	59H
2, 50	Type ID	Refer to table "Type ID" below	
3, 51	ROM version ID	Differs by ROM version.	

- Type ID If n=2, 50 is specified:

Bit	Meaning	Hex.	Decimal
0	Not equipped for 2 byte code support	00H	0
	Equipped for 2 byte code support	01H	1
1	Fixed	00H	0
2	Reserved	00H	0
3	Reserved	00H	0
4	Fixed	00H	0
5	Reserved	00H	0
6	Reserved	00H	0
7	Fixed	00H	0

- Sends the specified printer information.

n	Kind of Printer Information	Information
65	Firmware version	Differs by firmware version.
66	Manufacturer name	CITIZEN
67	Model name	BD2-2220
69	Kinds of multi-language fonts	Japanese Kanji specifications: KANJI JAPANESE
112	State of DSW	Refer to table "DSW" below (only serial model)

- Sends printer information specified by n=65 or more.

	Hex.	Number of Data
Header	5FH	1
Data	20H to 7FH	Subject to item to be responded
NULL	00H	1

- DSW If n=112 is specified:

Bit	Function	Hex.	Decimal
0	Dip switch [DSW5] is OFF	00H	0
	Dip switch [DSW5] is ON	01H	1
1	Dip switch [DSW6] is OFF	00H	0
	Dip switch [DSW6] is ON	02H	2
2	Dip switch [DSW7] is OFF	00H	0
	Dip switch [DSW7] is ON	04H	4
3	Dip switch [DSW8] is OFF	00H	0
	Dip switch [DSW8] is ON	08H	8
4	Reserved	00H	0
5	Reserved	00H	0
6	Fixed	40H	64
7	Fixed	00H	0

\*only serial model

## PMU series

n	Type of Printer ID	Specification	Value (Hex.)
1, 49	Model ID	PMU series	3DH
2, 50	Type ID	Refer to table "Type ID" below	
3, 51	ROM version ID	Differs by ROM version.	
		PMU2XXX	90H
		PMU2XXXII	A0H
	PMU2300III	B0H	
4, 52	Black mark Length	Depends on Black mark paper (mm)	

- Type ID If n=2, 50 is specified:

Bit	Meaning	Hex.	Decimal
0	Not equipped for 2 byte code support	00H	0
	Equipped for 2 byte code support	01H	1
1	Fixed	00H	0
2	Thermal paper	00H	0
	Black mark paper (when Black mark paper is selected)	04H	4
3	Reserved	00H	0
4	Fixed	00H	0
5	Reserved	00H	0
6	Reserved	00H	0
7	Fixed	00H	0

n = 4, 52 specified (only for B.M specs)

The Black mark length/label gap length and mark interval/label length currently used are returned in 4-byte code. All fractional parts in millimeters are rounded off.

Byte 1 + Byte 2 x256 = Black mark interval (2)

Byte 3 + Byte 4 x256 = Black mark length mm

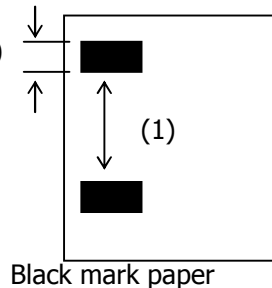

- Printer information configuration on and after transmitted n=65 is shown below.

n	Kind of Printer Information	Information
65	Firmware version	Differs by firmware version.
66	Manufacturer name	CITIZEN
67	Model name	PMU2XXX
		PMU2XXXII
		PMU2300III
69	Kinds of multi-language fonts	Japanese Kanji specifications: KANJI JAPANESE
112	State of DSW	Refer to table "DSW" below (only serial model)

- Sends printer information specified by n=65 or more.

	Hex.	Number of Data
Header	5FH	1
Data	20H to 7FH	Subject to item to be responded
NULL	00H	1

- DSW If n=112 is specified:

Bit	Function	Hex.	Decimal
0	Dip switch [DSW5] is OFF	00H	0
	Dip switch [DSW5] is ON	01H	1
1	Dip switch [DSW6] is OFF	00H	0
	Dip switch [DSW6] is ON	02H	2
2	Dip switch [DSW7] is OFF	00H	0
	Dip switch [DSW7] is ON	04H	4
3	Dip switch [DSW8] is OFF	00H	0
	Dip switch [DSW8] is ON	08H	8
4	Reserved	00H	0
5	Reserved	00H	0
6	Fixed	40H	64
7	Fixed	00H	0

\*only serial model

### CT-P29x series

n	Type of Printer ID	Specification	Value (Hex.)
1, 49	Model ID	CT-P29x series	7DH
2, 50	Type ID	Refer to table "Type ID" below	
3, 51	ROM version ID	Differs by ROM version.	

- Type ID If n=2, 50 is specified:

Bit	Meaning	Hex.	Decimal
0	Not equipped for 2 byte code support	00H	0
	Equipped for 2 byte code support	01H	1
1	Fixed	00H	0
2	Thermal paper	00H	0
3	Reserved	00H	0
4	Fixed	00H	0
5	Reserved	00H	0
6	Reserved	00H	0
7	Fixed	00H	0

- Printer information configuration on and after transmitted n=65 is shown below.

n	Kind of Printer Information	Information
65	Firmware version	Differs by firmware version.
66	Manufacturer name	CITIZEN
67	Model name	CT-P291/293 (Remark)
69	Kinds of multi-language fonts	Japanese Kanji specifications: KANJI JAPANESE
112	State of DSW	Refer to table "DSW" below (only serial model)

(Remarks) Model name depends on DSW setting (Refer to table "DSW")

- Sends printer information specified by n=65 or more.

	Hex.	Number of Data
Header	5FH	1
Data	20H to 7FH	Subject to item to be responded
NULL	00H	1

- DSW If n = 112 is specified:

Bit	Function	Hex.	Decimal
0	Dip switch [DSW8] is OFF	00H	0
	Dip switch [DSW8] is ON	01H	1
1	Dip switch [DSW7] is OFF	00H	0
	Dip switch [DSW7] is ON	02H	2
2	Dip switch [DSW6] is OFF	00H	0
	Dip switch [DSW6] is ON	04H	4
3	Dip switch [DSW5] is OFF	00H	0
	Dip switch [DSW5] is ON	08H	8
4	Dip switch [DSW4] is OFF	00H	0
	Dip switch [DSW4] is ON	10H	16
5	Dip switch [DSW3] is OFF	00H	0
	Dip switch [DSW3] is ON	20H	32
6	Dip switch [DSW2] is OFF	00H	0
	Dip switch [DSW2] is ON	40H	64
7	Dip switch [DSW1] is OFF	00H	0
	Dip switch [DSW1] is ON	80H	128

\*only serial model

# GS P x y

Support model	CT-S280	CT-S300	CT-S2000	CT-S4000	BD2-2220	PMU series
	CT-S281	CT-S310	CT-S801/851	CT-S601/651	CT-P29x series	CT-S310 II

**[Function]** Specifying the basic calculation pitch

**[Code]** <1D>H<50>H<x><y>

**[Range]**  $0 \leq x \leq 255$ ,  $0 \leq y \leq 255$

**[Outline]** **[The specification which is common to the model]**

- This command sets the horizontal basic calculation pitch to approx. 25.4/x mm (1/x inches), and the vertical basic calculation pitch to approx. 25.4/y mm (1/y inches).
- If x = 0, the horizontal basic calculation pitch is reverted to the default value.
- If y = 0, the vertical basic calculation pitch is reverted to the default value.

**[Caution]** **[The specification which is common to the model]**

- The horizontal direction is defined as the direction perpendicular to the paper feed, and the vertical direction is defined as the paper feed direction.
- In STANDARD MODE, the following parameters are used regardless of the character orientation (e.g. inverted or 90°-right-turned).
  - (1) Commands using x: ESC SP, ESC \$, ESC \, FS S, GS L, GS W
  - (2) Commands using y: ESC 3, ESC J
- In PAGE MODE, the parameters used depend on the character orientation, as follows:
  - (1) If the start point specified by ESC T is the top left or bottom right (The characters are mapped in the direction perpendicular to the paper feed):
    - Commands using x: ESC SP, ESC \$, ESC W, ESC \, FS S
    - Commands using y: ESC 3, ESC J, ESC W, GS \$, GS \
  - (2) If the start point specified by ESC T is the top right or bottom left (The characters are mapped in the paper feed direction):
    - Commands using x: ESC 3, ESC J, ESC W, GS \$, GS \
    - Commands using y: ESC SP, ESC \$, ESC W, ESC \, FS S
- This command does not affect any other values that are already set.
- If calculations made in combination with another command generate fractions, the fractions are corrected with the minimum pitch of the mechanism, and the remainder is omitted.

**[Default]** x=203, y=360

**[See Also]** [Appendix 5.1 "Explanation on PAGE MODE"](#)  
[ESC SP](#), [ESC \\$](#), [ESC 3](#), [ESC J](#), [ESC W](#), [ESC \](#), [GS \\$](#), [GS L](#), [GS W](#)

# ESC RS

Support model	CT-S280	CT-S300	CT-S2000	CT-S4000	BD2-2220	PMU series
	CT-S281	CT-S310	CT-S801/851	CT-S601/651	CT-P29x series	CT-S310 II

**[Function]** Sound buzzer

**[Code]** <1B>H<1E>H

**[Outline]** **[The specification which is common to the model]**

- Sound the buzzer for 200 ms.

**[Caution]** **[The specification which is common to the model]**

- This command is buffered before execution.

**[The specification which depend on the model]**

**CT-S310/CT-S2000/CT-S4000/CT-S801/CT-S851/CT-S601/CT-S651/CT-S301II**

- Sounds the buzzer when this command is entered even if buzzer is set to disabled with MSW5-1 OFF.

**[Sample Program]**

```
LPRINT CHR$(&H1B); CHR$(&H1E);
```

**[Execution Result]**

The buzzer sounds for approx. 200 ms.

### 3. CHARACTER CODE TABLE

#### 3.1 Code Page

##### 3.1.1 Codepage 00H to 7FH & PC437 (USA, Europe Standard)

	0	1	2	3	4	5	6	7	8	9	A	B	C	D	E	F
0	NUL	DLE		0	@	P	`	p	Ç	É	á	☼	┌	⊥	α	≡
1		XON	!	1	A	Q	a	q	ü	æ	í	▒	└	⊥	β	±
2			"	2	B	R	b	r	é	Æ	ó	▒	└	⊥	Γ	≥
3		XOFF	#	3	C	S	c	s	â	ô	ú		└	└	π	≤
4	EOT	DC4	\$	4	D	T	d	t	ä	ö	ñ	└	—	└	Σ	┌
5	ENQ		%	5	E	U	e	u	à	ò	Ñ	└	└	└	σ	└
6			&	6	F	V	f	v	å	û	ä	└	└	└	μ	÷
7			'	7	G	W	g	w	ç	ù	ø	└	└	└	τ	≈
8		CAN	(	8	H	X	h	x	ê	ÿ	¿	└	└	└	Φ	°
9	HT		)	9	I	Y	i	y	ë	Ö	└	└	└	└	θ	
A	LF		*	:	J	Z	j	z	è	Ü	└		└	└	Ω	·
B		ESC	+	;	K	[	k	{	ï	φ	½	└	└	■	δ	√
C	FF	FS	,	<	L	\	l		î	£	¼	└	└	■	∞	∞
D	CR	GS	-	=	M	]	m	}	ì	¥	ì	└	—	■	∅	²
E		RS	.	>	N	^	n	~	Ä	Pt	«	└	└	■	€	■
F			/	?	O	_	o	€	Å	f	»	└	└	■	∩	

### 3.1.2 Codepage 00H to 7FH & Katakana

	0	1	2	3	4	5	6	7	8	9	A	B	C	D	E	F
0	NUL	DLE		0	@	P	`	p	▬	┌	SP	-	タ	ミ	＝	×
1		XON	!	1	A	Q	a	q	▬	┐	°	ア	チ	ム	ト	円
2			"	2	B	R	b	r	▬	└	┌	イ	ツ	メ	+	年
3		XOFF	#	3	C	S	c	s	▬	└	└	ウ	テ	モ	ト	月
4	EOT	DC4	\$	4	D	T	d	t	▬	—	,	エ	ト	ヤ	▲	日
5	ENQ		%	5	E	U	e	u	▬	—	·	オ	ナ	ユ	▼	時
6			&	6	F	V	f	v	▬		ヲ	カ	ニ	ヨ	▼	分
7			'	7	G	W	g	w	▬		ア	キ	ヌ	ラ	▼	秒
8		CAN	(	8	H	X	h	x		┌	イ	ク	ネ	リ	♠	〒
9	HT		)	9	I	Y	i	y		┐	ウ	ケ	ノ	ル	♥	市
A	LF		*	:	J	Z	j	z		└	エ	コ	ハ	レ	◆	区
B		ESC	+	;	K	[	k	{		└	オ	サ	ヒ	ロ	♣	町
C	FF	FS	,	<	L	\	l			└	ヤ	シ	フ	ワ	●	村
D	CR	GS	-	=	M	]	m	}		└	ユ	ス	ヘ	ン	○	人
E		RS	.	>	N	^	n	~	▬	└	ヨ	セ	ホ	"	/	≡
F			/	?	O	_	o	€	+	└	ツ	ソ	マ	°	\	SP



### 3.1.3 Codepage 00H to 7FH & PC850 (Multilingual)

	0	1	2	3	4	5	6	7	8	9	A	B	C	D	E	F
0	NUL	DLE		0	@	P	`	p	Ç	É	á	☐	⌞	ð	Ó	-
1		XON	!	1	A	Q	a	q	ü	æ	í	☐	⌞	Ð	β	±
2			"	2	B	R	b	r	é	Æ	ó	☐	⌞	Ê	Ô	=
3		XOFF	#	3	C	S	c	s	â	ô	ú		⌞	Ë	Ò	¾
4	EOT	DC4	\$	4	D	T	d	t	ä	ö	ñ	⌞	—	È	õ	¶
5	ENQ		%	5	E	U	e	u	à	ò	Ñ	À	+	€	Ö	§
6			&	6	F	V	f	v	å	û	ä	Â	ã	Í	μ	÷
7			'	7	G	W	g	w	ç	ù	o	À	Ã	Î	þ	↳
8		CAN	(	8	H	X	h	x	ê	ÿ	¿	©	⌞	Ï	þ	°
9	HT		)	9	I	Y	i	y	ë	Ö	®	⌞	⌞	⌞	Ú	¨
A	LF		*	:	J	Z	j	z	è	Ü	¬		⌞	⌞	Û	·
B		ESC	+	;	K	[	k	{	ï	ø	½	⌞	⌞	■	Ü	¹
C	FF	FS	,	<	L	\	l		î	£	¼	⌞	⌞	■	Ý	³
D	CR	GS	-	=	M	]	m	}	ì	Ø	ì	¢	—	⌞	Ý	²
E		RS	.	>	N	^	n	~	Ä	×	«	¥	+	Ì	-	■
F			/	?	O	_	o	€	Å	f	»	⌞	⌞	■	'	

### 3.1.4 Codepage 00H to 7FH & PC860 (Portuguese)

	0	1	2	3	4	5	6	7	8	9	A	B	C	D	E	F
0	NUL	DLE		0	@	P	`	p	Ç	É	á		└	┘	α	≡
1		XON	!	1	A	Q	a	q	ü	À	í		┌	┐	β	±
2			"	2	B	R	b	r	é	È	ó		└	┘	Γ	≧
3		XOFF	#	3	C	S	c	s	â	ô	ú		└	┘	π	≦
4	EOT	DC4	\$	4	D	T	d	t	ã	õ	ñ	└	┘	└	Σ	┘
5	ENQ		%	5	E	U	e	u	à	ò	Ñ	└	┘	└	σ	┘
6			&	6	F	V	f	v	Á	Ú	a	└	┘	└	μ	÷
7			'	7	G	W	g	w	ç	ù	o	└	┘	└	τ	≈
8		CAN	(	8	H	X	h	x	ê	ï	¿	└	┘	└	Φ	°
9	HT		)	9	I	Y	i	y	Ë	Ö	Ó	└	┘	└	θ	
A	LF		*	:	J	Z	j	z	è	Ü	¬		└	┘	Ω	.
B		ESC	+	;	K	[	k	{	Í	ç	½	└	┘	■	δ	√
C	FF	FS	,	<	L	\	l		Ô	£	¼	└	┘	■	∞	∞
D	CR	GS	-	=	M	]	m	}	ì	Ù	i	└	┘	■	∅	₂
E		RS	.	>	N	^	n	~	Ã	Pt	«	└	┘	■	€	■
F			/	?	O	_	o	€	Â	Ó	»	└	┘	■	∩	

### 3.1.5 Codepage 00H to 7FH & PC863 (Canadian-French)

	0	1	2	3	4	5	6	7	8	9	A	B	C	D	E	F
0	NUL	DLE		0	@	P	`	p	Ç	É	!	☒	└	┘	α	≡
1		XON	!	1	A	Q	a	q	ü	È	'	☒	└	┘	β	±
2			"	2	B	R	b	r	é	Ê	ô	☒	└	┘	Γ	≧
3		XOFF	#	3	C	S	c	s	â	ô	ú		└	┘	π	≤
4	EOT	DC4	\$	4	D	T	d	t	Â	Ë	¨	└	└	└	Σ	┘
5	ENQ		%	5	E	U	e	u	à	Ï	˘	└	└	└	σ	┘
6			&	6	F	V	f	v	¶	û	³	└	└	└	μ	÷
7			'	7	G	W	g	w	ç	ù	-	└	└	└	τ	≈
8		CAN	(	8	H	X	h	x	ê	¸	î	└	└	└	Φ	◦
9	HT		)	9	I	Y	i	y	ë	Ô	˘	└	└	└	θ	
A	LF		*	:	J	Z	j	z	è	Ü	˘		└	└	Ω	·
B		ESC	+	;	K	[	k	{	ï	ç	½	└	└	■	δ	√
C	FF	FS	,	<	L	\	l		î	£	¼	└	└	■	∞	n
D	CR	GS	-	=	M	]	m	}	=	Ù	¾	└	└	■	∅	²
E		RS	.	>	N	^	n	~	À	Û	«	└	└	■	€	■
F			/	?	O	_	o	€	§	f	»	└	└	■	∩	

### 3.1.6 Codepage 00H to 7FH & PC865 (Nordic)

	0	1	2	3	4	5	6	7	8	9	A	B	C	D	E	F
0	NUL	DLE		0	@	P	`	p	Ç	É	á		┌	┐	α	≡
1		XON	!	1	A	Q	a	q	ü	æ	í		┌	┐	β	±
2			"	2	B	R	b	r	é	Æ	ó		┌	┐	Γ	≧
3		XOFF	#	3	C	S	c	s	â	ô	ú		┐	┌	π	≤
4	EOT	DC4	\$	4	D	T	d	t	ä	ö	ñ	┐	┌	┌	Σ	┌
5	ENQ		%	5	E	U	e	u	à	ò	Ñ	┐	┐	┐	σ	┌
6			&	6	F	V	f	v	å	û	ä	┐	┐	┐	μ	÷
7			'	7	G	W	g	w	ç	ù	ö	┐	┐	┐	τ	≈
8		CAN	(	8	H	X	h	x	ê	ÿ	¿	┐	┌	┐	Φ	°
9	HT		)	9	I	Y	i	y	ë	Ö	┐	┐	┐	┐	θ	
A	LF		*	:	J	Z	j	z	è	Ü	┐		┐	┐	Ω	·
B		ESC	+	;	K	[	k	{	ï	ø	½	┐	┐		δ	√
C	FF	FS	,	<	L	\	l		î	£	¼	┐	┐		∞	n
D	CR	GS	-	=	M	]	m	}	ì	Ø	i	┐	┐		∅	²
E		RS	.	>	N	^	n	~	Ä	Pt	«	┐	┐		€	■
F			/	?	O	_	o	€	Å	f	Ꝥ	┐	┐		∩	

### 3.1.7 Codepage 00H to 7FH & PC852 (Eastern Europe)

	0	1	2	3	4	5	6	7	8	9	A	B	C	D	E	F
0	NUL	DLE		0	@	P	`	p	Ç	É	á	☐	⌞	đ	Ó	-
1		XON	!	1	A	Q	a	q	ü	Ł	í	☐	⌞	Đ	β	"
2			"	2	B	R	b	r	é	Í	ó	☐	⌞	Đ	Ó	˘
3		XOFF	#	3	C	S	c	s	â	Ú	ú		⌞	Ë	Ń	˘
4	EOT	DC4	\$	4	D	T	d	t	ä	Ö	Ą	⌞	—	d'	Ń	˘
5	ENQ		%	5	E	U	e	u	ű	Ł	ą	Ą	⌞	Ń	Ń	§
6			&	6	F	V	f	v	ć	İ	Ż	Ą	Ą	İ	Ş	÷
7			'	7	G	W	g	w	ç	Ś	ż	Ę	Ą	î	Ş	˘
8		CAN	(	8	H	X	h	x	ł	Ś	Ę	Ş	⌞	ě	Ŕ	°
9	HT		)	9	I	Y	i	y	ë	Ö	ę	⌞	⌞	⌞	Ū	˘
A	LF		*	:	J	Z	j	z	ő	Ü	ł		⌞	⌞	Ŕ	˘
B		ESC	+	;	K	[	k	{	ó	Ť	ż	⌞	⌞	☐	Ū	ű
C	FF	FS	,	<	L	\	l		î		Č	⌞	⌞	☐	Ÿ	Ř
D	CR	GS	-	=	M	]	m	}	ž	ł	ş	Ż	—	Ť	Ÿ	ř
E		RS	.	>	N	^	n	~	Ä	x	«	Ž	⌞	Ū	Ť	■
F			/	?	O	_	o	€	Ć	Č	»	⌞	⌞	☐	'	SP

### 3.1.8 Codepage 00H to 7FH & PC866 (Russian)

	0	1	2	3	4	5	6	7	8	9	A	B	C	D	E	F
0	NUL	DLE		0	@	P	`	p	А	Р	а	▒	┌	└	р	Ё
1		XON	!	1	A	Q	a	q	Б	С	б	▓	┐	┘	с	ё
2			"	2	B	R	b	r	В	Т	в	█	└	┘	т	ё
3		XOFF	#	3	C	S	c	s	Г	У	г		┘	└	у	ё
4	EOT	DC4	\$	4	D	T	d	t	Д	Ф	д	┌	┐	└	ф	Ї
5	ENQ		%	5	E	U	e	u	Е	Х	е	┌	┐	└	ц	ї
6			&	6	F	V	f	v	Ж	Ц	ж	┌	┐	└	ц	ў
7			'	7	G	W	g	w	З	Ч	з	└	┘	┐	ч	
8		CAN	(	8	H	X	h	x	И	Ш	и	└	└	┐	х	°
9	HT		)	9	I	Y	i	y	Й	Щ	й	┌	└	┘	ш	▪
A	LF		*	:	J	Z	j	z	К	Ъ	к		└	└	щ	•
B		ESC	+	;	K	[	k	{	Л	Ы	л	└	└	▀	ь	Ў
C	FF	FS	,	<	L	\	l		М	Ь	м	└	└	▀	ы	No
D	CR	GS	-	=	M	]	m	}	Н	Э	н	└	└	┘	э	х
E		RS	.	>	N	^	n	~	О	Ю	о	└	└	┘	ю	▪
F			/	?	O	_	o	€	П	Я	п	└	└	▀	я	

### 3.1.9 Codepage 00H to 7FH & PC857 (Turkish)

	0	1	2	3	4	5	6	7	8	9	A	B	C	D	E	F
0	NUL	DLE		0	@	P	`	p	Ç	É	á	☐	⌞	o	ó	-
1		XON	!	1	A	Q	a	q	ü	æ	í	☐	⌞	a	β	±
2			"	2	B	R	b	r	é	Æ	ó	☐	⌞	È	ô	
3		XOFF	#	3	C	S	c	s	â	ô	ú		⌞	Ë	ò	¾
4	EOT	DC4	\$	4	D	T	d	t	à	ö	ñ	⌞	—	È	õ	¶
5	ENQ		%	5	E	U	e	u	ä	ò	Ñ	À	+		Ö	§
6			&	6	F	V	f	v	å	û	Ğ	Â	ã	í	μ	÷
7			'	7	G	W	g	w	ç	ù	ğ	À	Ã	î		↳
8		CAN	(	8	H	X	h	x	ê	Í	¿	©	⌞	ï	×	°
9	HT		)	9	I	Y	i	y	ë	Ö	®	⌞	⌞	⌞	Ú	¨
A	LF		*	:	J	Z	j	z	è	Ü	¬		⌞	⌞	Û	.
B		ESC	+	;	K	[	k	{	ï	ø	½	⌞	⌞	■	Ü	1
C	FF	FS	,	<	L	\	l		î	£	¼	⌞	⌞	■	Û	3
D	CR	GS	-	=	M	]	m	}	İ	Ø	i	ç	—	⌞	ÿ	2
E		RS	.	>	N	^	n	~	Ä	Ş	«	¥	+	İ	-	■
F			/	?	O	_	o	€	Å	ş	»	⌞	×	■	'	SP

3.1.10 Codepage 00H to 7FH & PC864 (Arabic)

	0	1	2	3	4	5	6	7	8	9	A	B	C	D	E	F
0	NUL	DLE		0	@	P	`	p	°	β	(RSP)	•	¢	ذ	ـ	ﻩ
1		XON	!	1	A	Q	a	q	•	∞	(SHY)	۱	۲	ر	ف	س
2			”	2	B	R	b	r	•	φ	آ	۲	آ	ز	ق	ن
3		XOFF	#	3	C	S	c	s	√	±	£	۳	أ	س	ك	ه
4	EOT	DC4	\$	4	D	T	d	t	■	½	⊗	۴	ؤ	ش	ل	ف
5	ENQ		%	5	E	U	e	u	▬	¼	ل	۵	ع	ط	م	و
6			&	6	F	V	f	v	▬	≈		۶	ع	ظ	ن	ي
7			'	7	G	W	g	w	▬	«		۷	ا	ط	ه	غ
8		CAN	(	8	H	X	h	x	▬	»	ا	۸	ب	ظ	و	ق
9	HT		)	9	I	Y	i	y	▬	لأ	ب	۹	ة	ع	ي	لأ
A	LF		*	:	J	Z	j	z	▬	لأ	ت	ف	ت	غ	ي	لأ
B		ESC	+	;	K	[	k	{	▬		ث	؛	ث	ا	ض	ل
C	FF	FS	,	<	L	\	l		▬		،	س	ج	ا	ع	ك
D	CR	GS	-	=	M	]	m	}	▬	لا	ج	ش	ج	÷	غ	ي
E		RS	.	>	N	^	n	~	▬	لا	ح	ص	خ	×	غ	■
F			/	?	O	_	o		▬	،	خ	؟	د	ع	م	



### 3.1.11 Codepage 00H to 7FH & Windows Codepage

	0	1	2	3	4	5	6	7	8	9	A	B	C	D	E	F
0	NUL	DLE		0	@	P	`	p				°	À	Ð	à	ð
1		XON	!	1	A	Q	a	q		`	i	±	Á	Ñ	á	ñ
2			"	2	B	R	b	r		'	¢	²	Â	Ò	â	ò
3		XOFF	#	3	C	S	c	s	f	"	£	³	Ã	Ó	ã	ó
4	EOT	DC4	\$	4	D	T	d	t	"	"	¤	'	Ä	Ô	ä	ô
5	ENQ		%	5	E	U	e	u	...	.	¥	µ	Å	Õ	å	õ
6			&	6	F	V	f	v		-	¦	¶	Æ	Ö	æ	ö
7			'	7	G	W	g	w		-	§	·	Ç	×	ç	÷
8		CAN	(	8	H	X	h	x		~	¨	¸	È	Ø	è	ø
9	HT		)	9	I	Y	i	y	‰	™	©	¹	É	Ù	é	ù
A	LF		*	:	J	Z	j	z	Š	š	ª	º	Ê	Ú	ê	ú
B		ESC	+	;	K	[	k	{	<	>	«	»	Ë	Û	ë	û
C	FF	FS	,	<	L	\	l		Œ	œ	¬	¼	Ï	Ü	ï	ü
D	CR	GS	-	=	M	]	m	}			-	½	Í	Ý	í	ý
E		RS	.	>	N	^	n	~			®	¾	Î	Þ	î	þ
F			/	?	O	_	o	€		ÿ	¯	¿	Ï	ß	ï	ÿ

3.1.12 Codepage 00H to 7FH & Thai code 18

	0	1	2	3	4	5	6	7	8	9	A	B	C	D	E	F
0	NUL	DLE		0	@	P	`	p	Г	๙		ฐ	ภ	๕	ใ	๐
1		XON	!	1	A	Q	a	q	Г	๑	ก	ท	ม	๑	แ	๑
2			"	2	B	R	b	r	L	๑	ข	ฒ	ย	๓	โ	๓
3		XOFF	#	3	C	S	c	s	J	๕	ช	ฒ	ร	๓	ใ	๓
4	EOT	DC4	\$	4	D	T	d	t		๕	ค	ค	ถ	๓	ใ	๕
5	ENQ		%	5	E	U	e	u	-	๕+	ค	ค	ถ	๓	๓	๕
6			&	6	F	V	f	v	┌	๓-	ฆ	ถ	ภ	๓	๓	๖
7			'	7	G	W	g	w	└	๓	ง	ท	ว	๓	๕	๗
8		CAN	(	8	H	X	h	x	┘	๓	จ	ถ	ค	๓	๓	๘
9	HT		)	9	I	Y	i	y	T	๓+	ฉ	น	ช	๓	๓	๙
A	LF		*	:	J	Z	j	z	┘	๓	ช	บ	ฉ	๓	๓	๙
B		ESC	+	;	K	[	k	{	■	๓-	ช	บ	ท	๓-	+	๓-
C	FF	FS	,	<	L	\	l		←	๓	ฒ	ฒ	ฒ	๓	๓	๓
D	CR	GS	-	=	M	]	m	}	↑	๓	ฒ	ฒ	ฒ	๓	๓	๓
E		RS	.	>	N	^	n	~	→	๓+	ภ	พ	อ	๓+	๓	๓+
F			/	?	O	_	o		↓	๓	ภ	พ	๓	๓	๓	

### 3.2 International Character Code Table

	Country	23	24	40	5B	5C	5D	5E	60	7B	7C	7D	7E
0	U.S.A	#	\$	@	[	\	]	^	'	{		}	~
1	France	#	\$	à	°	ç	§	^	'	é	ù	è	¨
2	Germany	#	\$	§	Ä	Ö	Ü	^	'	ä	ö	ü	ß
3	U.K.	£	\$	@	[	\	]	^	'	{		}	~
4	Denmark I	#	\$	@	Æ	Ø	Å	^	'	æ	ø	å	~
5	Sweden	#	⌘	É	Ä	Ö	Å	Ü	é	ä	ö	å	ü
6	Italy	#	\$	@	°	\	é	^	ù	à	ò	è	ì
7	Spain I	Pt	\$	@	i	Ñ	¿	^	'	¨	ñ	}	~
8	Japan	#	\$	@	[	¥	]	^	'	{		}	~
9	Norway	#	⌘	É	Æ	Ø	Å	Ü	é	æ	ø	å	ü
10	Denmark II	#	\$	É	Æ	Ø	Å	Ü	é	æ	ø	å	ü
11	Spain II	#	\$	á	i	Ñ	¿	é	'	ì	ñ	ó	ú
12	Latin America	#	\$	á	i	Ñ	¿	é	ü	ì	ñ	ó	ú
13	Korea	#	\$	@	[	₩	]	^	'	{		}	~
14	Croatia	#	\$	Ž	Š	Đ	Č	Č	ž	š	đ	ć	č
15	China	#	¥	@	[	¥	]	^	'	{		}	~

### 3.3 Kanji Code Table

#### 3.3.1 JIS non-Kanji

S-JIS	JIS	0	1	2	3	4	5	6	7	8	9	A	B	C	D	E	F
813F	2120			/	°	,	.	·	:	;	?	!	˘	˙	´	˘	˙
814F	2130	^	—	—	∖	∕	↳	↵	〃	全	≠	○	○	-	-	-	/
815F	2140	¥	~	∥		…	∴	、	、	“	”	(	)	[	]	[	]
816F	2150	{	}	<	>	《	》	「	」	『	』	【	】	+	-	±	×
8180	2160	÷	=	≠	<	>	≤	≥	∞	∴	♂	♀	°	′	″	℃	¥
8190	2170	\$	¢	£	%	#	&	*	@	§	☆	★	○	●	◎	◇	
819E	2220		◆	□	■	△	▲	▽	▼	*	〒	→	←	↑	↓	=	
81AE	2230											∈	∋	⊆	⊇	⊂	⊃
81BE	2240	U	∩									∧	∨	¬	⇒	⇔	∇
81CE	2250	∃												∠	⊥	∩	∂
81DE	2260	∇	≡	≐	≪	≫	√	∞	∞	∴	∫	∫					
81EE	2270			Å	‰	#	b	♪	†	‡	¶						○
823F	2320																
824F	2330	0	1	2	3	4	5	6	7	8	9						
825F	2340		A	B	C	D	E	F	G	H	I	J	K	L	M	N	O
826F	2350	P	Q	R	S	T	U	V	W	X	Y	Z					
8280	2360		a	b	c	d	e	f	g	h	i	j	k	l	m	n	o
8290	2370	p	q	r	s	t	u	v	w	x	y	z					
829E	2420		あ	あ	い	い	う	う	え	え	お	お	か	が	き	ぎ	く
82AE	2430	ぐ	け	げ	こ	ご	さ	ざ	し	じ	す	ず	せ	ぜ	そ	ぞ	た
82BE	2440	だ	ち	ぢ	っ	つ	づ	て	で	と	ど	な	に	ぬ	ね	の	は
82CE	2450	ば	ぱ	ひ	び	ぴ	ふ	ぶ	ぷ	へ	べ	ぺ	ほ	ぼ	ぽ	ま	み
82DE	2460	む	め	も	ゃ	や	ゆ	ゆ	よ	よ	ら	り	る	れ	ろ	わ	わ
82EE	2470	ゐ	ゑ	を	ん												
833F	2520		ア	ア	イ	イ	ウ	ウ	エ	エ	オ	オ	カ	ガ	キ	ギ	ク
834F	2530	グ	ケ	ゲ	コ	ゴ	サ	ザ	シ	ジ	ス	ズ	セ	ゼ	ソ	ゾ	タ
835F	2540	ダ	チ	ヂ	ツ	ツ	ヅ	テ	デ	ト	ド	ナ	ニ	ヌ	ネ	ノ	ハ
836F	2550	バ	パ	ヒ	ビ	ピ	フ	ブ	プ	ヘ	ベ	ペ	ホ	ボ	ポ	マ	ミ
8380	2560	ム	メ	モ	ャ	ヤ	ユ	ユ	ヨ	ヨ	ラ	リ	ル	レ	ロ	ワ	ワ
8390	2570	ヰ	ヱ	ヲ	ン	ヴ	カ	ケ									
839E	2620		A	B	Γ	Δ	E	Z	H	Θ	I	K	Λ	M	N	Ξ	O
83AE	2630	Π	P	Σ	T	Υ	Φ	X	Ψ	Ω							
83BE	2640		α	β	γ	δ	ε	ζ	η	θ	ι	κ	λ	μ	ν	ξ	ο
83CE	2650	π	ρ	σ	τ	υ	φ	χ	ψ	ω							
83DE	2660																
83EE	2670																

S-JIS	JIS	0	1	2	3	4	5	6	7	8	9	A	B	C	D	E	F
843F	2720		А	Б	В	Г	Д	Е	Ё	Ж	З	И	Й	К	Л	М	Н
844F	2730	О	П	Р	С	Т	У	Ф	Х	Ц	Ч	Ш	Щ	Ъ	Ы	Ь	Э
845F	2740	Ю	Я														
846F	2750		а	б	в	г	д	е	ё	ж	з	и	й	к	л	м	н
8480	2760	о	п	р	с	т	у	ф	х	ц	ч	ш	щ	ъ	ы	ь	э
8490	2770	ю	я														
849E	2820		—		┌	┐	└	┘	├	┤	┥	┦	┧	┨	┩	┪	┫
84AE	2830	┌	┐	└	┘	├	┤	┥	┦	┧	┨	┩	┪	┫	┬	┭	┮
84BE	2840	├															
84CE	2850																
84DE	2860																
84EE	2870																

### 3.3.2 JIS Kanji Level 1

S-JIS	JIS	0	1	2	3	4	5	6	7	8	9	A	B	C	D	E	F
889E	3020		啞	啞	娃	阿	哀	愛	挨	始	逢	葵	茜	穉	惡	握	渥
88AE	3030	旭	葦	芦	鱒	梓	庄	幹	扱	宛	姐	虻	飴	絢	綾	鮎	或
88BE	3040	粟	裕	安	庵	按	暗	案	闇	鞍	杏	以	伊	位	依	偉	困
88CE	3050	夷	委	威	尉	惟	意	慰	易	椅	為	畏	異	移	維	緯	胃
88DE	3060	萎	衣	謂	違	遺	医	井	亥	域	育	郁	磯	一	壹	溢	逸
88EE	3070	稻	茨	芋	鯛	允	印	咽	員	因	姻	引	飲	淫	胤	蔭	
893F	3120		院	陰	隱	韻	吋	右	宇	烏	羽	迂	雨	卯	鵠	窺	丑
894F	3130	碓	臼	渦	噓	唄	鬱	蔚	鰻	姥	厩	浦	瓜	閏	噂	云	運
895F	3140	雲	荏	餌	叡	營	嬰	影	映	曳	榮	永	泳	洩	瑛	盈	穎
896F	3150	穎	英	衛	詠	銳	液	疫	益	馱	悅	謁	越	閱	榎	厭	円
8980	3160	園	堰	奄	宴	延	怨	掩	援	沿	演	炎	焰	煙	燕	猿	縁
8990	3170	艷	苑	園	遠	鉛	鴛	塩	於	汚	甥	凹	央	奧	往	応	
899E	3220		押	旺	橫	欧	殴	王	翁	襖	鶯	鷗	黄	岡	冲	荻	億
89AE	3230	屋	憶	臆	桶	牡	乙	俺	卸	恩	温	穩	音	下	化	仮	何
89BE	3240	伽	伽	佳	加	可	嘉	夏	嫁	家	寡	科	暇	果	架	歌	河
89CE	3250	火	珂	禍	禾	稼	箇	花	苛	茄	荷	華	菓	蝦	課	嘩	貨
89DE	3260	迦	過	霞	蚊	俄	峨	我	牙	画	臥	芽	蛾	賀	雅	餓	駕
89EE	3270	介	会	解	回	塊	壞	廻	快	怪	悔	恢	懷	戒	拐	改	
8A3F	3320		魁	晦	械	海	灰	界	皆	繪	芥	蟹	開	階	貝	凱	効
8A4F	3330	外	咳	害	崖	慨	概	涯	碍	蓋	街	該	鎧	骸	涇	馨	蛙
8A5F	3340	垣	柿	蛎	鈎	劃	嚇	各	廓	扞	攪	格	核	殼	獲	確	穫
8A6F	3350	覺	角	赫	較	郭	閣	隔	革	学	岳	樂	額	顎	掛	笠	檉
8A80	3360	檀	梶	鰍	渴	割	喝	恰	括	活	渴	滑	葛	褐	轄	且	鯉
8A90	3370	叶	柁	樺	鞞	株	兜	竈	蒲	釜	鎌	嚙	鴨	栢	茅	萱	
8A9E	3420		粥	刈	苜	瓦	乾	侃	冠	寒	刊	勘	勸	卷	喚	堪	姦
8AAE	3430	完	官	寬	干	幹	患	感	慣	憾	換	敢	柑	桓	棺	款	歡
8ABE	3440	汗	漢	澗	灌	環	甘	監	看	竿	管	簡	緩	缶	翰	肝	艦
8ACE	3450	莞	觀	諫	貫	還	鑑	間	閑	閑	陷	韓	館	館	丸	含	岸
8ADE	3460	巖	玩	癌	眼	岩	翫	贗	雁	頑	顏	願	企	伎	危	喜	器
8AEE	3470	基	奇	嬉	寄	岐	希	幾	忌	揮	机	旗	既	伎	棋	棄	
8B3F	3520		機	歸	毅	氣	汽	畿	祈	季	稀	紀	徽	規	記	貴	起
8B4F	3530	軌	輝	飢	騎	鬼	龜	偽	儀	妓	宜	戲	技	擬	欺	犧	疑
8B5F	3540	祇	義	蟻	誼	議	掬	菊	鞠	吉	吃	喫	桔	橘	詰	砧	杵
8B6F	3550	黍	却	客	脚	虐	逆	丘	久	仇	休	及	吸	宮	弓	急	救
8B80	3560	朽	求	汲	泣	灸	球	究	窮	笈	級	糾	給	旧	牛	去	居
8B90	3570	巨	拒	拋	拳	渠	虛	許	距	鋸	漁	禦	魚	亨	享	京	

S-JIS	JIS	0	1	2	3	4	5	6	7	8	9	A	B	C	D	E	F
8B9E	3620		供	俠	僑	兇	競	共	凶	協	匡	卿	叫	喬	境	峽	強
8BAE	3630	疆	怯	恐	恭	挾	教	橋	況	狂	狹	矯	胸	脅	興	蕎	鄉
8BBE	3640	鏡	響	饗	驚	仰	凝	堯	曉	業	局	曲	極	玉	桐	籽	僅
8BCE	3650	勤	均	巾	錦	斤	欣	欽	琴	禁	禽	筋	緊	芹	菌	衿	襟
8BDE	3660	謹	近	金	吟	銀	九	俱	句	區	狗	玖	矩	苦	軀	馭	駟
8BEE	3670	駒	具	愚	虞	喰	空	偶	寓	遇	隅	串	櫛	釧	屑	屈	
8C3F	3720		掘	窟	沓	靴	轡	窪	熊	隈	彖	栗	繰	桑	鋤	勳	君
8C4F	3730	薰	訓	群	軍	郡	卦	袈	祁	係	傾	刑	兄	啓	圭	珪	型
8C5F	3740	契	形	徑	惠	慶	慧	憩	揭	携	敬	景	桂	溪	畦	稽	系
8C6F	3750	經	繼	繫	罴	荃	荊	蚩	計	詣	警	輕	頸	鷄	芸	迎	鯨
8C80	3760	劇	戟	擊	激	隙	析	傑	欠	決	潔	穴	結	血	訣	月	件
8C90	3770	儉	倦	健	兼	券	劍	喧	圈	堅	嫌	建	憲	懸	拳	捲	
C89E	3820		檢	權	牽	犬	獻	研	硯	絹	梟	肩	見	謙	賢	軒	遣
8CAE	3830	鍵	險	顯	驗	齧	元	原	蔽	幻	弦	減	源	玄	現	絃	舷
8CBE	3840	言	諺	限	乎	個	古	呼	固	姑	孤	己	庫	弧	戶	故	枯
8CCE	3850	湖	狐	糊	袴	股	胡	菰	虎	誇	跨	鈷	雇	顧	鼓	五	互
8CDE	3860	伍	午	吳	吾	娛	後	御	悟	梧	檣	瑚	碁	語	誤	護	醐
8CEE	3870	乞	鯉	交	佼	侯	候	倖	光	公	功	効	勾	厚	口	向	
8D3F	3920		后	喉	坑	垢	好	孔	孝	宏	工	巧	巷	幸	広	庚	康
8D4F	3930	弘	恒	慌	抗	拘	控	攻	昂	晃	更	杭	校	梗	構	江	洪
8D5F	3940	浩	港	溝	甲	皇	硬	稿	糠	紅	紘	絞	綱	耕	考	肯	肱
8D6F	3950	腔	膏	航	荒	行	衡	講	貢	購	郊	酵	鈷	砒	鋼	閤	降
8D80	3960	項	香	高	鴻	剛	劫	号	合	壕	拷	濠	豪	轟	麴	克	刻
8D90	3970	告	国	穀	酷	鵠	黑	獄	漉	腰	甌	忽	惚	骨	狍	込	
8D9E	3A20		此	頃	今	困	坤	墾	婚	恨	懇	昏	昆	根	梱	混	痕
8DAE	3A30	紺	艮	魂	些	佐	又	唆	嵯	左	差	查	沙	磋	砂	詐	鎖
8DBE	3A40	袞	坐	座	挫	債	催	再	最	哉	塞	妻	宰	彩	才	採	栽
8DCE	3A50	歲	濟	災	采	犀	碎	砦	祭	齋	細	崎	裁	載	際	劑	在
8DDE	3A60	材	罪	財	冴	坂	阪	堺	榭	肴	咲	崎	埼	碕	鷺	作	削
8DEE	3A70	咋	搾	昨	朔	柵	窄	策	索	錯	桜	鮭	笹	匙	冊	刷	
8E3F	3B20		察	拶	撮	擦	札	殺	薩	雜	阜	鯖	捌	鎔	鮫	皿	晒
8E4F	3B30	三	傘	參	山	慘	撒	散	棧	燦	珊	產	算	纂	蚕	讚	贛
8E5F	3B40	酸	餐	斬	暫	殘	仕	仔	伺	使	刺	司	史	嗣	四	士	始
8E6F	3B50	姉	姿	子	屍	市	師	志	思	指	支	孜	斯	施	旨	枝	止
8E80	3B60	死	氏	獅	祉	私	糸	紙	紫	肢	脂	至	視	詞	詩	試	誌
8E90	3B70	諮	資	賜	雌	飼	鹵	事	似	侍	兒	字	寺	慈	持	時	

S-JIS	JIS	0	1	2	3	4	5	6	7	8	9	A	B	C	D	E	F
8E9E	3C20		次	滋	治	爾	璽	痔	磁	示	而	耳	自	蒔	辞	汐	鹿
8EAE	3C30	式	識	鳴	竺	軸	央	雫	七	叱	執	失	嫉	室	悉	湿	漆
8EBE	3C40	疾	質	実	蔀	篠	俚	柴	芝	屢	蕊	縞	舍	写	射	捨	赦
8ECE	3C50	斜	煮	社	紗	者	謝	車	遮	蛇	邪	借	勺	尺	杓	灼	爵
8EDE	3C60	酌	积	錫	若	寂	弱	惹	主	取	守	手	朱	殊	狩	珠	種
8EEE	3C70	腫	趣	酒	首	儒	受	呪	寿	授	樹	綬	需	囚	収	周	
8F3F	3D20		宗	就	州	修	愁	拾	洲	秀	秋	終	繡	習	臭	舟	蒐
8F4F	3D30	衆	襲	讐	蹴	輯	週	酋	酬	集	醜	什	住	充	十	從	戎
8F5F	3D40	柔	汁	洪	獸	縱	重	銃	叔	夙	宿	淑	祝	縮	肅	塾	熟
8F6F	3D50	出	術	述	俊	峻	春	瞬	竣	舜	駿	准	循	旬	楯	殉	淳
8F80	3D60	準	潤	盾	純	巡	遵	醇	順	処	初	所	暑	曙	渚	庶	緒
8F90	3D70	署	書	薯	諸	諸	助	叙	女	序	徐	所	恕	鋤	除	傷	償
8F9E	3E20		勝	匠	升	召	哨	商	唱	嘗	獎	妾	娼	宵	将	小	少
8FAE	3E30	尚	庄	床	廠	彰	承	抄	招	掌	捷	昇	昌	昭	晶	松	梢
8FBE	3E40	樟	樵	沼	消	涉	湘	燒	焦	照	症	省	硝	礁	祥	称	章
8FCE	3E50	笑	粧	紹	肖	苜	蔣	蕉	衝	裳	訟	証	詔	詳	象	賞	醬
8FDE	3E60	鉦	鍾	鐘	障	鞘	上	丈	丞	乘	冗	剩	城	場	壤	孃	常
8FEE	3E70	情	擾	条	杖	淨	状	畳	穰	蒸	讓	釀	錠	囑	埴	飾	
903F	3F20		拭	植	殖	燭	織	職	色	触	食	蝕	辱	尻	伸	信	侵
904F	3F30	唇	娠	寢	審	心	慎	振	新	晋	森	榛	浸	深	申	疹	真
905F	3F40	神	秦	紳	臣	芯	薪	親	診	身	辛	進	針	震	人	仁	刃
906F	3F50	塵	壬	尋	甚	尽	腎	訊	迅	陣	韌	筭	諏	須	酢	囟	厨
9080	3F60	逗	吹	垂	帥	推	水	炊	睡	粹	翠	袁	遂	醉	錘	錘	随
9090	3F70	瑞	髓	崇	嵩	数	枢	趨	雛	据	杉	相	菅	頗	雀	裾	
909E	4020		澄	摺	寸	世	瀨	畝	是	淒	制	勢	姓	征	性	成	政
90AE	4030	整	星	晴	棲	栖	正	清	牲	生	盛	精	聖	声	製	西	誠
90BE	4040	誓	請	逝	醒	青	静	齐	税	脆	隻	席	惜	戚	斥	昔	析
90CE	4050	石	積	籍	績	脊	責	赤	跡	蹟	碩	切	拙	接	撰	折	設
90DE	4060	窃	節	說	雪	絶	舌	蟬	仙	先	千	占	宣	專	尖	川	戰
90EE	4070	扇	撰	栓	栴	泉	浅	洗	染	潜	煎	煽	旋	穿	箭	線	
913F	4120		織	羨	腺	舛	船	薦	詮	賤	踐	選	遷	錢	銑	閃	鮮
914F	4130	前	善	漸	然	全	禪	繕	膳	糲	噌	塑	岨	措	曾	曾	楚
915F	4140	狙	疏	疎	礎	祖	租	粗	素	組	蘇	訴	阻	遡	鼠	僧	創
916F	4150	双	叢	倉	喪	壯	奏	爽	宋	層	匝	惣	想	搜	掃	挿	搔
9180	4160	操	早	曹	巢	槍	槽	漕	燥	争	瘦	相	窓	糟	総	綜	聡
9190	4170	草	莊	葬	蒼	藻	装	走	送	遭	鎗	霜	騷	像	増	憎	



S-JIS	JIS	0	1	2	3	4	5	6	7	8	9	A	B	C	D	E	F
919E	4220		臟	藏	贈	造	促	側	則	即	息	捉	束	測	足	速	俗
91AE	4230	屬	賊	族	統	卒	袖	其	揃	存	孫	尊	損	村	遜	他	多
91BE	4240	太	汰	訖	唾	墮	妥	情	打	柁	舵	椅	陀	馱	驛	体	堆
91CE	4250	对	耐	岱	帶	待	怠	態	戴	替	泰	滯	胎	腿	苔	袋	貸
91DE	4260	退	逮	隊	黛	鯛	代	台	大	第	醜	題	鷹	滝	瀧	卓	啄
91EE	4270	宅	托	扞	拓	沢	濯	琢	託	鐸	濁	諾	茸	胤	蛸	只	
923F	4320		叩	但	達	辰	奪	脱	巽	豎	汕	棚	谷	狸	鱒	樽	誰
924F	4330	丹	單	嘆	坦	担	探	旦	歎	淡	湛	炭	短	端	筭	綻	耽
925F	4340	胆	蛋	誕	鍛	团	壇	彈	断	暖	檀	段	男	談	值	知	地
926F	4350	弛	恥	智	池	痴	稚	置	致	蜘	遲	馳	築	畜	竹	筑	蓄
9280	4360	逐	秩	窒	茶	嫡	着	中	仲	宙	忠	抽	昼	柱	注	虫	衷
9290	4370	註	耐	鑄	駐	櫛	瀦	猪	苧	著	貯	丁	兆	凋	喋	寵	
929E	4420		帖	帳	庁	弔	張	彫	徵	懲	挑	暢	朝	潮	牒	町	眺
92AE	4430	聽	脹	腸	蝶	調	諜	超	跳	銚	長	頂	烏	勅	抄	直	朕
92BE	4440	沈	珍	賃	鎮	陳	津	墜	椎	槌	追	鎚	痛	通	塚	柁	捆
92CE	4450	槻	佃	漬	柘	辻	蔦	綴	鏢	椿	潰	坪	壺	孀	紬	爪	吊
92DE	4460	釣	鶴	亭	低	停	偵	荆	貞	呈	堤	定	帝	底	庭	廷	弟
92EE	4470	悌	抵	挺	提	梯	汀	碇	禎	程	締	艇	訂	諦	蹄	遞	
933F	4520		邸	鄭	釘	鼎	泥	摘	擢	敵	滴	的	笛	適	鎬	溺	哲
934F	4530	徹	撤	轍	迭	鉄	典	填	天	展	店	添	纏	甜	貼	轉	顛
935F	4540	点	伝	殿	澱	田	電	兔	吐	堵	塗	妬	屠	徒	斗	杜	渡
936F	4550	登	菟	賭	途	都	鍍	砥	砺	努	度	土	奴	怒	倒	党	冬
9380	4560	凍	刀	唐	塔	塘	套	宕	島	嶋	悼	投	搭	東	桃	棹	棟
9390	4570	盜	淘	湯	涛	灯	燈	当	痘	禱	等	答	筒	糖	統	到	
939E	4620		董	蕩	藤	討	騰	豆	踏	逃	透	鐙	陶	頭	騰	鬪	働
93AE	4630	動	同	堂	導	懂	撞	洞	瞳	童	胴	苟	道	銅	峠	鴉	匿
93BE	4640	得	德	澆	特	督	禿	篤	毒	独	読	析	橡	凸	突	椽	届
93CE	4650	鳶	苦	寅	酉	滯	噸	屯	惇	敦	沌	豚	遁	頓	吞	曇	鈍
93DE	4660	奈	那	内	乍	凧	薙	謎	灘	捺	鍋	槽	馴	繩	啜	南	楠
93EE	4670	軟	難	汝	二	尼	弑	迹	勻	賑	肉	虹	廿	日	乳	入	
943F	4720		如	尿	菲	任	妊	忍	認	濡	襦	祢	寧	葱	猫	熱	年
944F	4730	念	捻	撚	燃	粘	乃	迺	之	埜	囊	惱	濃	納	能	腦	膿
945F	4740	農	覲	蚤	巴	把	播	霸	杷	波	派	琶	破	婆	罵	芭	馬
946F	4750	俳	廢	拜	排	敗	杯	盃	牌	背	肺	輩	配	倍	培	媒	梅
9480	4760	楳	煤	猥	買	壳	賠	陪	這	蠅	秤	矧	菽	伯	剥	博	拍
9490	4770	柏	泊	白	箔	粕	舶	薄	迫	曝	漠	爆	縛	莫	駁	麥	

S-JIS	JIS	0	1	2	3	4	5	6	7	8	9	A	B	C	D	E	F
949E	4820		函	箱	裕	箸	肇	筈	櫨	幡	肌	畑	畠	八	鉢	澆	堯
94AE	4830	醜	髮	伐	罰	拔	筏	閱	鳩	嘶	塙	蛤	隼	伴	判	半	反
94BE	4840	叛	帆	搬	斑	板	汜	汎	版	犯	班	畔	繁	般	藩	販	範
94CE	4850	采	煩	頒	飯	挽	晚	番	盤	磐	蕃	蚤	匪	卑	否	妃	庇
94DE	4860	彼	悲	扉	批	披	斐	比	泌	疲	皮	碑	秘	緋	罷	肥	被
94EE	4870	誹	費	避	非	飛	樋	簸	備	尾	微	枇	毘	毳	眉	美	
953F	4920		鼻	柁	稗	匹	疋	髭	彥	膝	菱	肘	弼	必	畢	筆	逼
954F	4930	桧	姬	媛	紐	百	謬	俵	彪	標	氷	漂	瓢	票	表	評	豹
955F	4940	廟	描	病	秒	苗	錨	鉦	蒜	蛭	鱮	品	彬	斌	浜	瀕	貧
956F	4950	竇	頻	敏	瓶	不	付	埠	夫	婦	富	富	布	府	怖	扶	敷
9580	4960	斧	普	浮	父	符	腐	膚	芙	譜	負	賦	赴	阜	附	侮	撫
9590	4970	武	舞	葡	蕪	部	封	楓	風	葺	落	伏	副	復	幅	服	
959E	4A20		福	腹	複	覆	淵	弗	弘	沸	仏	物	鮪	分	吻	噴	墳
95AE	4A30	憤	扮	焚	奮	粉	糞	紛	雰	文	聞	丙	併	兵	塀	幣	平
95BE	4A40	弊	柄	並	蔽	閉	陛	米	頁	僻	壁	癖	碧	別	瞥	蔑	篋
95CE	4A50	偏	變	片	篇	編	辺	返	遍	便	勉	婉	弁	鞭	保	舖	鋪
95DE	4A60	圃	捕	步	甫	補	輔	穗	募	墓	慕	戊	暮	母	簿	菩	倣
95EE	4A70	俸	包	呆	報	奉	宝	峰	峯	崩	庖	抱	捧	放	方	朋	
963F	4B20		法	泡	烹	砲	縫	胞	芳	萌	蓬	蜂	褒	訪	豐	邦	鋒
964F	4B30	飽	鳳	鵬	乏	亡	傍	剖	坊	妨	帽	忘	忙	房	暴	望	某
965F	4B40	棒	冒	紡	肪	膨	謀	貌	貿	鉞	防	吠	頰	北	僕	卜	墨
966F	4B50	撲	朴	牧	睦	穆	鈞	勃	沒	殆	堀	幌	奔	本	翻	凡	盆
9680	4B60	摩	磨	魔	麻	埋	妹	昧	枚	每	哩	楨	幕	膜	枕	鮪	枉
9690	4B70	鱒	桫	亦	俣	又	抹	末	沫	迄	俛	繭	磨	万	慢	滿	
969E	4C20		漫	蔓	味	未	魅	巳	箕	岬	密	蜜	湊	蓑	稔	脈	妙
96AE	4C30	耗	民	眠	務	夢	無	牟	矛	霧	鷓	棕	婿	娘	冥	名	命
96BE	4C40	明	盟	迷	銘	鳴	姪	牝	滅	免	棉	綿	緬	面	麵	摸	模
96CE	4C50	茂	妄	孟	毛	猛	盲	網	耗	蒙	儲	木	默	目	杳	勿	餅
96DE	4C60	尤	戾	勑	賁	問	悶	紋	門	匆	也	冶	夜	爺	耶	野	弥
96EE	4C70	矢	厄	役	約	藥	訖	躍	靖	柳	藪	鎚	愉	愈	油	癒	
973F	4D20		諭	輸	唯	佑	優	勇	友	宥	幽	悠	憂	揖	有	柚	湧
974F	4D30	涌	猶	猷	由	祐	裕	誘	遊	邑	郵	雄	融	夕	予	余	与
975F	4D40	譽	輿	預	傭	幼	妖	容	庸	揚	搖	擁	曜	楊	樣	洋	溶
976F	4D50	熔	用	窯	羊	耀	葉	蓉	要	謠	踊	遙	陽	養	慾	抑	欲
9780	4D60	沃	浴	翌	翼	淀	羅	螺	裸	來	萊	賴	雷	洛	絡	落	酪
9790	4D70	乱	卵	嵐	欄	濫	藍	蘭	覽	利	吏	履	李	梨	理	璃	

S-JIS	JIS	0	1	2	3	4	5	6	7	8	9	A	B	C	D	E	F
979E	4E20		痢	裏	裡	里	離	陸	律	率	立	莅	掠	略	劉	流	溜
97AE	4E30	琉	留	硫	粒	隆	竜	龍	侶	慮	旅	虜	了	亮	僚	兩	凌
97BE	4E40	寮	料	梁	涼	獵	療	瞭	稜	糧	良	諒	遼	量	陵	領	力
97CE	4E50	緑	倫	厘	林	淋	隣	琳	臨	輪	隣	鱗	麟	溜	壘	淚	累
97DE	4E60	類	令	伶	例	冷	勵	嶺	伶	玲	礼	苓	鈴	隸	零	靈	麗
97EE	4E70	齡	曆	歷	列	劣	烈	裂	廉	恋	憐	漣	煉	簾	練	聯	
983F	4F20		蓮	連	鍊	呂	魯	櫓	炉	路	路	露	勞	婁	廊	弄	朗
984F	4F30	樓	榔	浪	漏	牢	狼	籠	老	壘	蠟	郎	六	麓	祿	肋	録
985F	4F40	論	倭	和	話	歪	賄	脇	惑	梓	鷺	瓦	亘	鱒	詫	藁	蕨
986F	4F50	椀	湾	碗	腕												
9880	4F60																
9890	4F70																

3.3.3 JIS Kanji Level 2

S-JIS	JIS	0	1	2	3	4	5	6	7	8	9	A	B	C	D	E	F
989E	5020		弌	丐	丕	个	卩	丿	井	丿	乂	乖	乘	亂	丿	豫	事
98AE	5030	舒	弌	于	亞	亟	一	亢	京	毫	亘	从	仍	仄	仆	仂	仗
98BE	5040	仞	仞	仞	价	伉	侏	估	佛	佝	佗	佇	佶	侈	侏	侗	佻
98CE	5050	佩	佰	侑	伴	來	侖	儘	俛	俟	俎	俘	俛	俑	俚	侗	侑
98DE	5060	俚	倚	倨	倔	倪	倥	倅	倅	倣	倡	倩	倬	倭	俯	們	倆
98EE	5070	偃	假	會	借	修	偈	做	偕	偈	偷	傀	倣	傅	偃	傲	
993F	5120		僉	僊	傳	僂	僖	僞	僥	僭	僭	僮	價	僵	儉	僑	儂
994F	5130	儼	儕	儔	儖	儗	儘	儙	儚	儛	儜	兀	兒	兌	免	兢	競
995F	5140	兩	兪	兮	冀	冂	回	册	冉	冏	冑	冓	冕	冂	冤	冢	冢
996F	5150	寫	冢	冫	决	冫	冲	冰	况	冽	涸	凉	凜	几	處	冫	凭
9980	5160	凰	冫	函	又	刊	刂	刂	刂	刂	刂	刂	刂	刂	刂	刂	刂
9990	5170	劊	剔	剪	剝	剩	剝	剝	剝	剝	剝	剝	剝	剝	剝	剝	剝
999E	5220		劬	劬	劬	劬	劬	劬	劬	劬	劬	劬	劬	劬	劬	劬	劬
99AE	5230	勸	勸	勸	勸	勸	勸	勸	勸	勸	勸	勸	勸	勸	勸	勸	勸
99BE	5240	𠂇	卅	卅	卉	卂	準	卂	卂	卂	卂	卂	卷	厂	厖	厖	厦
99CE	5250	厥	厥	厥	厶	參	纂	雙	叟	曼	變	叮	叨	叭	叭	吁	吽
99DE	5260	呀	听	吭	吼	吮	呐	吩	吝	呖	咏	呵	咎	咎	呱	呷	咎
99EE	5270	咒	呻	咀	呶	咄	咐	咆	哇	号	咸	啞	咬	哄	哈	咨	
9A3F	5320		咫	晒	咤	咤	咤	咤	哥	哦	唏	唔	哽	哮	哭	哺	哂
9A4F	5330	嗽	哇	啣	啣	售	啣	啣	啣	啣	啣	啣	啣	啣	啣	啣	啣
9A5F	5340	啣	啣	啣	啣	啣	啣	啣	啣	啣	啣	啣	啣	啣	啣	啣	啣
9A6F	5350	啣	啣	啣	啣	啣	啣	啣	啣	啣	啣	啣	啣	啣	啣	啣	啣
9A80	5360	噫	噤	嘯	噬	噪	噤	噤	噤	噤	噤	噤	噤	噤	噤	噤	噤
9A90	5370	嚼	囁	囁	囁	囁	囁	囁	囁	囁	囁	囁	囁	囁	囁	囁	囁
9A9E	5420		圀	國	圍	圓	團	圖	嗇	園	圀	圀	圀	圀	圀	圀	圀
9AAE	5430	坩	垂	垚	坡	坩	坩	垓	垓	垓	垓	垓	垓	垓	垓	垓	垓
9ABE	5440	埤	埤	埤	埤	埤	埤	埤	埤	埤	埤	埤	埤	埤	埤	埤	埤
9ACE	5450	墅	壩	墟	墩	塢	壞	墻	墻	墻	墻	壓	壑	墟	壙	壘	壘
9ADE	5460	壘	壤	壘	壯	壺	壹	壻	壺	壽	久	久	夂	夂	夢	夥	夂
9AEE	5470	夭	夂	夸	夾	奇	奕	奂	奎	奚	奘	奢	奠	奧	獎	奘	
9B3F	5520		奸	妁	妝	佞	佞	妣	妣	姆	姨	姜	妍	姪	姚	娥	娟
9B4F	5530	娑	娜	娉	娉	娉	娉	娉	娉	娉	娉	娉	娉	娉	娉	娉	娉
9B5F	5540	媽	媽	媽	娉	嫩	嫖	嫖	嫖	嬌	嬋	嬋	嬋	嬋	嬋	嬋	嬋
9B6F	5550	孃	孃	孃	子	孕	孚	孛	孛	孩	孰	孳	孳	孳	孳	孳	孳
9B80	5560	它	宦	宸	冤	寇	霍	寔	寔	寔	實	寔	寔	寔	寫	寔	寶
9B90	5570	寶	尅	將	專	對	尔	尅	尅	尅	尸	尹	屁	屈	屎	屙	

S-JIS	JIS	0	1	2	3	4	5	6	7	8	9	A	B	C	D	E	F
9B9E	5620		屨	屨	屨	屬	屮	屮	岾	屹	岾	岑	岔	岾	岫	岷	岫
9BAE	5630	岬	岷	岷	岫	岫	峙	峩	峩	峩	峭	崑	峪	崑	崑	崑	崑
9BBE	5640	崑	崑	崑	崑	崑	崑	崑	崑	崑	崑	崑	崑	崑	崑	崑	崑
9BCE	5650	崑	崑	崑	崑	崑	崑	崑	崑	崑	崑	崑	崑	崑	崑	崑	崑
9BDE	5660	巫	巳	卮	帀	帀	帀	帀	帀	帀	帀	帀	帀	帀	帀	帀	帀
9BEE	5670	幟	幟	幣	幫	幟	幟	幟	幟	幟	幟	幟	幟	幟	幟	幟	幟
9C3F	5720		廖	廣	廡	廚	廡	廢	廡	廡	廡	廡	廡	廡	廡	廡	廡
9C4F	5730	升	弃	莽	彘	彘	弋	弋	弋	弋	弋	弋	弋	弋	弋	弋	弋
9C5F	5740	彘	彘	彘	彘	彘	彘	彘	彘	彘	彘	彘	彘	彘	彘	彘	彘
9C6F	5750	徙	徙	徠	徠	徠	徠	徠	徠	徠	徠	徠	徠	徠	徠	徠	徠
9C80	5760	怙	怙	怙	怙	怙	怙	怙	怙	怙	怙	怙	怙	怙	怙	怙	怙
9C90	5770	協	恆	恍	恣	恃	恤	恂	恂	恂	恂	恂	恂	恂	恂	恂	恂
9C9E	5820		悄	悛	悛	悛	悛	悛	悛	悛	悛	悛	悛	悛	悛	悛	悛
9CAE	5830	悛	悛	悛	悛	悛	悛	悛	悛	悛	悛	悛	悛	悛	悛	悛	悛
9CBE	5840	慍	慍	慍	慍	慍	慍	慍	慍	慍	慍	慍	慍	慍	慍	慍	慍
9CCE	5850	慍	慍	慍	慍	慍	慍	慍	慍	慍	慍	慍	慍	慍	慍	慍	慍
9CDE	5860	慍	慍	慍	慍	慍	慍	慍	慍	慍	慍	慍	慍	慍	慍	慍	慍
9CEE	5870	慍	慍	慍	慍	慍	慍	慍	慍	慍	慍	慍	慍	慍	慍	慍	慍
9D3F	5920		戛	戛	戛	戛	戛	戛	戛	戛	戛	戛	戛	戛	戛	戛	戛
9D4F	5930	扞	扞	扞	扞	扞	扞	扞	扞	扞	扞	扞	扞	扞	扞	扞	扞
9D5F	5940	扞	扞	扞	扞	扞	扞	扞	扞	扞	扞	扞	扞	扞	扞	扞	扞
9D6F	5950	扞	扞	扞	扞	扞	扞	扞	扞	扞	扞	扞	扞	扞	扞	扞	扞
9D80	5960	扞	扞	扞	扞	扞	扞	扞	扞	扞	扞	扞	扞	扞	扞	扞	扞
9D90	5970	扞	扞	扞	扞	扞	扞	扞	扞	扞	扞	扞	扞	扞	扞	扞	扞
9D9E	5A20		據	據	據	據	據	據	據	據	據	據	據	據	據	據	據
9DAE	5A30	攬	攬	攬	攬	攬	攬	攬	攬	攬	攬	攬	攬	攬	攬	攬	攬
9DBE	5A40	攬	攬	攬	攬	攬	攬	攬	攬	攬	攬	攬	攬	攬	攬	攬	攬
9DCE	5A50	斟	斫	斫	斫	斫	斫	斫	斫	斫	斫	斫	斫	斫	斫	斫	斫
9DDE	5A60	晟	旻	旻	旻	旻	旻	旻	旻	旻	旻	旻	旻	旻	旻	旻	旻
9DEE	5A70	晟	皙	晰	晁	暈	暈	暈	暈	暈	暈	暈	暈	暈	暈	暈	暈
9E3F	5B20		曄	曄	曄	曄	曄	曄	曄	曄	曄	曄	曄	曄	曄	曄	曄
9E4F	5B30	隴	霸	朮	束	朮	朮	朮	朮	朮	朮	朮	朮	朮	朮	朮	朮
9E5F	5B40	柰	杼	杪	粉	枋	枋	枋	枋	枋	枋	枋	枋	枋	枋	枋	枋
9E6F	5B50	柰	柰	柰	柰	柰	柰	柰	柰	柰	柰	柰	柰	柰	柰	柰	柰
9E80	5B60	梳	柰	柰	柰	柰	柰	柰	柰	柰	柰	柰	柰	柰	柰	柰	柰
9E90	5B70	梵	柰	柰	柰	柰	柰	柰	柰	柰	柰	柰	柰	柰	柰	柰	柰

S-JIS	JIS	0	1	2	3	4	5	6	7	8	9	A	B	C	D	E	F
9E9E	5C20		楮	棧	棕	櫻	椒	接	棗	棣	桤	棹	棠	楡	桤	桤	桤
9EAE	5C30	楨	楸	楸	楸	楸	楸	楸	楸	楸	楸	楸	楸	楸	楸	楸	楸
9EBE	5C40	楸	楸	楸	楸	楸	楸	楸	楸	楸	楸	楸	楸	楸	楸	楸	楸
9ECE	5C50	楸	楸	楸	楸	楸	楸	楸	楸	楸	楸	楸	楸	楸	楸	楸	楸
9EDE	5C60	楸	楸	楸	楸	楸	楸	楸	楸	楸	楸	楸	楸	楸	楸	楸	楸
9EEE	5C70	楸	楸	楸	楸	楸	楸	楸	楸	楸	楸	楸	楸	楸	楸	楸	楸
9F3F	5D20		楸	楸	楸	楸	楸	楸	楸	楸	楸	楸	楸	楸	楸	楸	楸
9F4F	5D30	楸	楸	楸	楸	楸	楸	楸	楸	楸	楸	楸	楸	楸	楸	楸	楸
9F5F	5D40	楸	楸	楸	楸	楸	楸	楸	楸	楸	楸	楸	楸	楸	楸	楸	楸
9F6F	5D50	楸	楸	楸	楸	楸	楸	楸	楸	楸	楸	楸	楸	楸	楸	楸	楸
9F80	5D60	楸	楸	楸	楸	楸	楸	楸	楸	楸	楸	楸	楸	楸	楸	楸	楸
9F90	5D70	楸	楸	楸	楸	楸	楸	楸	楸	楸	楸	楸	楸	楸	楸	楸	楸
9F9E	5E20		楸	楸	楸	楸	楸	楸	楸	楸	楸	楸	楸	楸	楸	楸	楸
9FAE	5E30	楸	楸	楸	楸	楸	楸	楸	楸	楸	楸	楸	楸	楸	楸	楸	楸
9FBE	5E40	楸	楸	楸	楸	楸	楸	楸	楸	楸	楸	楸	楸	楸	楸	楸	楸
9FCE	5E50	楸	楸	楸	楸	楸	楸	楸	楸	楸	楸	楸	楸	楸	楸	楸	楸
9FDE	5E60	楸	楸	楸	楸	楸	楸	楸	楸	楸	楸	楸	楸	楸	楸	楸	楸
9FEE	5E70	楸	楸	楸	楸	楸	楸	楸	楸	楸	楸	楸	楸	楸	楸	楸	楸
E03F	5F20		楸	楸	楸	楸	楸	楸	楸	楸	楸	楸	楸	楸	楸	楸	楸
E04F	5F30	楸	楸	楸	楸	楸	楸	楸	楸	楸	楸	楸	楸	楸	楸	楸	楸
E05F	5F40	楸	楸	楸	楸	楸	楸	楸	楸	楸	楸	楸	楸	楸	楸	楸	楸
E06F	5F50	楸	楸	楸	楸	楸	楸	楸	楸	楸	楸	楸	楸	楸	楸	楸	楸
E080	5F60	楸	楸	楸	楸	楸	楸	楸	楸	楸	楸	楸	楸	楸	楸	楸	楸
E090	5F70	楸	楸	楸	楸	楸	楸	楸	楸	楸	楸	楸	楸	楸	楸	楸	楸
E09E	6020		楸	楸	楸	楸	楸	楸	楸	楸	楸	楸	楸	楸	楸	楸	楸
E0AE	6030	楸	楸	楸	楸	楸	楸	楸	楸	楸	楸	楸	楸	楸	楸	楸	楸
E0BE	6040	楸	楸	楸	楸	楸	楸	楸	楸	楸	楸	楸	楸	楸	楸	楸	楸
E0CE	6050	楸	楸	楸	楸	楸	楸	楸	楸	楸	楸	楸	楸	楸	楸	楸	楸
E0DE	6060	楸	楸	楸	楸	楸	楸	楸	楸	楸	楸	楸	楸	楸	楸	楸	楸
E0EE	6070	楸	楸	楸	楸	楸	楸	楸	楸	楸	楸	楸	楸	楸	楸	楸	楸
E13F	6120		楸	楸	楸	楸	楸	楸	楸	楸	楸	楸	楸	楸	楸	楸	楸
E14F	6130	楸	楸	楸	楸	楸	楸	楸	楸	楸	楸	楸	楸	楸	楸	楸	楸
E15F	6140	楸	楸	楸	楸	楸	楸	楸	楸	楸	楸	楸	楸	楸	楸	楸	楸
E16F	6150	楸	楸	楸	楸	楸	楸	楸	楸	楸	楸	楸	楸	楸	楸	楸	楸
E180	6160	楸	楸	楸	楸	楸	楸	楸	楸	楸	楸	楸	楸	楸	楸	楸	楸
E190	6170	楸	楸	楸	楸	楸	楸	楸	楸	楸	楸	楸	楸	楸	楸	楸	楸

S-JIS	JIS	0	1	2	3	4	5	6	7	8	9	A	B	C	D	E	F
E19E	6220		癩	𤑔	癸	發	皂	兒	販	皋	皎	皖	皓	皙	皚	皑	皛
E1AE	6230	鞞	輝	皺	孟	盍	盖	盒	盞	盞	盞	盞	盞	盞	盞	盞	盞
E1BE	6240	眇	眩	昵	眞	眚	眦	眵	眵	眵	眵	眵	眵	眵	眵	眵	眵
E1CE	6250	聿	睹	瞎	瞋	瞋	瞋	瞋	瞋	瞋	瞋	瞋	瞋	瞋	瞋	瞋	瞋
E1DE	6260	轟	矚	矜	矣	矮	矸	砌	砒	礦	砒	礪	硅	碎	砒	砒	砒
E1EE	6270	砒	砒	砒	砒	砒	砒	砒	砒	砒	砒	砒	砒	砒	砒	砒	砒
E23F	6320		磧	磚	磽	磽	磽	磽	磽	磽	磽	磽	磽	磽	磽	磽	磽
E24F	6330	祕	祓	祺	祿	禊	禊	禊	禊	禊	禊	禊	禊	禊	禊	禊	禊
E25F	6340	秬	秣	秣	稈	稍	稭	稭	稭	稭	稭	稭	稭	稭	稭	稭	稭
E26F	6350	穉	穉	穉	穉	穉	穉	穉	穉	穉	穉	穉	穉	穉	穉	穉	穉
E280	6360	婁	竅	竄	窿	邃	竇	竊	竄	竄	竄	竄	竄	竄	竄	竄	竄
E290	6370	竦	竭	婭	笄	笄	笄	笄	笄	笄	笄	笄	笄	笄	笄	笄	笄
E29E	6420		筐	笄	筍	笋	筌	筌	筌	筌	筌	筌	筌	筌	筌	筌	筌
E2AE	6430	箇	篋	籬	筍	筍	筍	筍	筍	筍	筍	筍	筍	筍	筍	筍	筍
E2BE	6440	篋	篩	篋	篋	篋	篋	篋	篋	篋	篋	篋	篋	篋	篋	篋	篋
E2CE	6450	簧	簪	簪	簪	簪	簪	簪	簪	簪	簪	簪	簪	簪	簪	簪	簪
E2DE	6460	籐	籐	籐	籐	籐	籐	籐	籐	籐	籐	籐	籐	籐	籐	籐	籐
E2EE	6470	粽	糝	糝	糝	糝	糝	糝	糝	糝	糝	糝	糝	糝	糝	糝	糝
E33F	6520		紂	紂	紂	紂	紂	紂	紂	紂	紂	紂	紂	紂	紂	紂	紂
E34F	6530	絨	絮	絨	絨	絨	絨	絨	絨	絨	絨	絨	絨	絨	絨	絨	絨
E35F	6540	綫	總	綫	綫	綫	綫	綫	綫	綫	綫	綫	綫	綫	綫	綫	綫
E36F	6550	縵	縣	縵	縵	縵	縵	縵	縵	縵	縵	縵	縵	縵	縵	縵	縵
E380	6560	縵	縵	縵	縵	縵	縵	縵	縵	縵	縵	縵	縵	縵	縵	縵	縵
E390	6570	辦	縵	縵	縵	縵	縵	縵	縵	縵	縵	縵	縵	縵	縵	縵	縵
E39E	6620		罇	罇	罇	罇	罇	罇	罇	罇	罇	罇	罇	罇	罇	罇	罇
E3AE	6630	羈	羈	羈	羈	羈	羈	羈	羈	羈	羈	羈	羈	羈	羈	羈	羈
E3BE	6640	羈	羈	羈	羈	羈	羈	羈	羈	羈	羈	羈	羈	羈	羈	羈	羈
E3CE	6650	耒	耘	耜	耜	耜	耜	耜	耜	耜	耜	耜	耜	耜	耜	耜	耜
E3DE	6660	聳	聳	聳	聳	聳	聳	聳	聳	聳	聳	聳	聳	聳	聳	聳	聳
E3EE	6670	胛	胛	胛	胛	胛	胛	胛	胛	胛	胛	胛	胛	胛	胛	胛	胛
E43F	6720		膾	膾	膾	膾	膾	膾	膾	膾	膾	膾	膾	膾	膾	膾	膾
E44F	6730	膾	膾	膾	膾	膾	膾	膾	膾	膾	膾	膾	膾	膾	膾	膾	膾
E45F	6740	臉	臍	臍	臍	臍	臍	臍	臍	臍	臍	臍	臍	臍	臍	臍	臍
E46F	6750	與	舊	舍	舐	舖	舩	舩	舩	舩	舩	舩	舩	舩	舩	舩	舩
E480	6760	牆	朦	膾	膾	膾	膾	膾	膾	膾	膾	膾	膾	膾	膾	膾	膾
E490	6770	莖	苟	苒	苒	苒	苒	苒	苒	苒	苒	苒	苒	苒	苒	苒	苒

S-JIS	JIS	0	1	2	3	4	5	6	7	8	9	A	B	C	D	E	F
E49E	6820		茵	茴	茗	苾	茱	荀	茹	荐	苔	茯	茫	茗	荔	莅	莛
E4AE	6830	莪	蒼	莢	莖	莫	莎	苳	莊	茶	菟	荳	葱	莠	莉	苙	菴
E4BE	6840	萱	董	崑	菽	萃	崧	萋	菁	葶	萇	菠	菲	萍	范	萌	莽
E4CE	6850	萸	菱	苐	葭	菴	萼	萸	葳	葶	葫	葛	葭	蒂	葩	葆	萬
E4DE	6860	葯	施	蒿	蒨	葢	蒹	蒿	蒟	蔞	蒼	蒟	蔞	蔞	藜	蓆	蕘
E4EE	6870	莠	蔡	蓎	蓐	蔗	蔘	蔬	蔴	蔴	荀	蔘	蔴	蔞	蕘	蔞	
E53F	6920		葶	藥	蒨	蔞	蔞	蔞	蔞	蔞	蔞	蔞	蔞	蔞	蔞	蔞	蔞
E54F	6930	蔞	蔞	蔞	蔞	蔞	蔞	蔞	蔞	蔞	蔞	蔞	蔞	蔞	蔞	蔞	蔞
E55F	6940	蔞	蔞	蔞	蔞	蔞	蔞	蔞	蔞	蔞	蔞	蔞	蔞	蔞	蔞	蔞	蔞
E56F	6950	蚩	蚪	蚋	蚌	蚶	蚯	蛄	蛆	蚰	蛉	蠓	蚰	蛔	蛞	蛭	蝥
E580	6960	蛟	蛛	蛭	蜒	蚬	蜈	蜀	蜃	蛻	蟹	蟬	蝮	蛹	蛭	蛭	蛭
E590	6970	蝮	蜻	蜥	蝮	蜚	蝠	蝮	蝮	蝮	蝮	蝮	蝮	蝮	蝮	蝮	蝮
E59E	6A20		蝮	蝮	蝮	蝮	蝮	蝮	蝮	蝮	蝮	蝮	蝮	蝮	蝮	蝮	蝮
E5AE	6A30	蝮	蝮	蝮	蝮	蝮	蝮	蝮	蝮	蝮	蝮	蝮	蝮	蝮	蝮	蝮	蝮
E5BE	6A40	蠕	蠹	蠹	蠹	蠹	蠹	蠹	蠹	蠹	衄	衄	衄	衄	衄	衄	衄
E5CE	6A50	衄	衄	衄	衄	衄	衄	衄	衄	衄	衄	衄	衄	衄	衄	衄	衄
E5DE	6A60	袂	袂	袂	袂	袂	袂	袂	袂	袂	袂	袂	袂	袂	袂	袂	袂
E5EE	6A70	袂	袂	袂	袂	袂	袂	袂	袂	袂	袂	袂	袂	袂	袂	袂	袂
E63F	6B20		襦	襦	襦	襦	襦	襦	襦	襦	襦	襦	襦	襦	襦	襦	襦
E64F	6B30	覲	覲	覲	覲	覲	覲	覲	覲	覲	觚	觚	觚	觚	觚	覲	覲
E65F	6B40	訐	訐	訐	訐	訐	訐	訐	訐	訐	訐	訐	訐	訐	訐	訐	訐
E66F	6B50	詭	詭	詭	詭	詭	詭	詭	詭	詭	詭	詭	詭	詭	詭	詭	詭
E680	6B60	諤	諤	諤	諤	諤	諤	諤	諤	諤	諤	諤	諤	諤	諤	諤	諤
E690	6B70	謳	謳	謳	謳	謳	謳	謳	謳	謳	謳	謳	謳	謳	謳	謳	謳
E69E	6C20		譟	譟	譟	譟	譟	譟	譟	譟	譟	譟	譟	譟	譟	譟	譟
E6AE	6C30	谿	豈	豈	豈	豈	豈	豈	豈	豈	豈	豈	豈	豈	豈	豈	豈
E6BE	6C40	貌	貍	貍	貍	貍	貍	貍	貍	貍	貍	貍	貍	貍	貍	貍	貍
E6CE	6C50	賽	賺	賺	賺	賺	贊	贊	贊	贖	贖	贖	贖	贖	贖	贖	贖
E6DE	6C60	赅	赅	赅	赅	赅	赅	赅	赅	赅	赅	赅	赅	赅	赅	赅	赅
E6EE	6C70	跟	跣	跣	跣	跣	跣	跣	跣	跣	跣	跣	跣	跣	跣	跣	跣
E73F	6D20		蹇	蹇	蹇	蹇	蹇	蹇	蹇	蹇	蹇	蹇	蹇	蹇	蹇	蹇	蹇
E74F	6D30	躅	躅	躅	躅	躅	躅	躅	躅	躅	躅	躅	躅	躅	躅	躅	躅
E75F	6D40	輿	輿	輿	輿	輿	輿	輿	輿	輿	輿	輿	輿	輿	輿	輿	輿
E76F	6D50	輿	輿	輿	輿	輿	輿	輿	輿	輿	輿	輿	輿	輿	輿	輿	輿
E780	6D60	輿	輿	輿	輿	輿	輿	輿	輿	輿	輿	輿	輿	輿	輿	輿	輿
E790	6D70	迓	迹	迓	迓	迓	迓	迓	迓	迓	迓	迓	迓	迓	迓	迓	迓



S-JIS	JIS	0	1	2	3	4	5	6	7	8	9	A	B	C	D	E	F
E79E	6E20		遏	遐	遑	迢	迢	迢	逾	適	邁	遞	遨	遯	遶	隨	遲
E7AE	6E30	邂	遽	邁	邀	邊	邊	邏	邨	邨	邱	邵	郢	郤	扈	郛	鄂
E7BE	6E40	鄒	鄙	鄆	鄰	酏	酏	醅	酏	酥	醅	醅	醅	醋	醉	醜	醜
E7CE	6E50	醫	醯	醪	醪	醴	醴	釀	釀	釉	釋	釐	釵	釵	釜	釵	釵
E7DE	6E60	釵	鈹	鈞	鈦	鈔	鈦	鈕	鈹	鈹	鈹	鉅	鉉	鉤	鈇	鈇	鈇
E7EE	6E70	鈹	鈹	銜	銖	銓	銖	鈹	鈹	鈹	鈹	鉅	鉉	鉤	鈇	鈇	鈇
E83F	6F20		錙	錢	錚	鋳	鋳	鈇	鈇	鈇	鎰	鎰	鎰	鎰	鎰	鎰	鎰
E84F	6F30	鎰	鎰	鑿	鏗	鑿	鎰	鎰	鎰	鎰	鎰	鎰	鎰	鎰	鎰	鎰	鎰
E85F	6F40	鑄	鑄	鑄	鑄	鑄	鑄	鑄	鑄	鑄	鑄	鑄	鑄	鑄	鑄	鑄	鑄
E86F	6F50	鑄	鑄	鑄	鑄	鑄	鑄	鑄	鑄	鑄	鑄	鑄	鑄	鑄	鑄	鑄	鑄
E880	6F60	閏	閏	閏	閏	閏	閏	閏	閏	閏	閏	閏	閏	閏	閏	閏	閏
E890	6F70	關	關	關	關	阡	阡	阡	阡	阡	阡	阡	阡	阡	阡	阡	阡
E89E	7020		陝	陟	陟	陟	陟	陟	陟	陟	陟	陟	陟	陟	陟	陟	陟
E8AE	7030	隶	隸	隸	隸	隸	隸	隸	隸	隸	隸	隸	隸	隸	隸	隸	隸
E8BE	7040	霽	霽	霽	霽	霽	霽	霽	霽	霽	霽	霽	霽	霽	霽	霽	霽
E8CE	7050	靜	靠	靠	靠	靠	靠	靠	靠	靠	靠	靠	靠	靠	靠	靠	靠
E8DE	7060	鞋	鞋	鞋	鞋	鞋	鞋	鞋	鞋	鞋	鞋	鞋	鞋	鞋	鞋	鞋	鞋
E8EE	7070	韶	韶	韶	韶	韶	韶	韶	韶	韶	韶	韶	韶	韶	韶	韶	韶
E93F	7220		顛	顛	顛	顛	顛	顛	顛	顛	顛	顛	顛	顛	顛	顛	顛
E94F	7230	舖	餘	餡	飭	餞	餞	餅	餡	餡	餡	餡	餡	餡	餡	餡	餡
E95F	7240	饑	饒	饒	饒	饒	饒	馭	馭	馭	馭	馭	馭	馭	馭	馭	馭
E96F	7250	駁	駁	駁	駁	駁	駁	駁	駁	駁	駁	駁	駁	駁	駁	駁	駁
E980	7260	騾	驕	驕	驕	驕	驕	驕	驕	驕	驕	驕	驕	驕	驕	驕	驕
E990	7270	髀	髀	髀	髀	髀	髀	髀	髀	髀	髀	髀	髀	髀	髀	髀	髀
E99E	7220		髻	髻	髻	髻	髻	髻	髻	髻	髻	髻	髻	髻	髻	髻	髻
E9AE	7230	魄	魃	魏	魃	魃	魃	魃	魃	魃	魃	魃	魃	魃	魃	魃	魃
E9BE	7240	魃	魃	魃	魃	魃	魃	魃	魃	魃	魃	魃	魃	魃	魃	魃	魃
E9CE	7250	魃	魃	魃	魃	魃	魃	魃	魃	魃	魃	魃	魃	魃	魃	魃	魃
E9DE	7260	魃	魃	魃	魃	魃	魃	魃	魃	魃	魃	魃	魃	魃	魃	魃	魃
E9EE	7270	魃	魃	魃	魃	魃	魃	魃	魃	魃	魃	魃	魃	魃	魃	魃	魃
EA3F	7320		鵝	鵝	鵝	鵝	鵝	鵝	鵝	鵝	鵝	鵝	鵝	鵝	鵝	鵝	鵝
EA4F	7330	鵝	鵝	鵝	鵝	鵝	鵝	鵝	鵝	鵝	鵝	鵝	鵝	鵝	鵝	鵝	鵝
EA5F	7340	鸚	鸚	鸚	鸚	鸚	鸚	鸚	鸚	鸚	鸚	鸚	鸚	鸚	鸚	鸚	鸚
EA6F	7350	麩	麩	麩	麩	麩	麩	麩	麩	麩	麩	麩	麩	麩	麩	麩	麩
EA80	7360	徽	麩	麩	麩	麩	麩	麩	麩	麩	麩	麩	麩	麩	麩	麩	麩
EA90	7370	麩	麩	麩	麩	麩	麩	麩	麩	麩	麩	麩	麩	麩	麩	麩	麩

S-JIS	JIS	0	1	2	3	4	5	6	7	8	9	A	B	C	D	E	F
<b>EA9E</b>	<b>7420</b>		堯	禛	遙	瑤											
<b>EAAE</b>	<b>7430</b>																
<b>EABE</b>	<b>7440</b>																
<b>EACE</b>	<b>7450</b>																
<b>EADE</b>	<b>7460</b>																
<b>EAAE</b>	<b>7470</b>																

## 4. Memory Switch

Memory switch is a function to save the user selected settings into NV memory, where memory switch setting will be held unless memory switch is changed.

Memory switch is changed by manual setting or by command in the memory switch change mode.

\* Hereafter, memory switch is referred to as MSW.

### 4.1 Memory Switches

#### 4.1.1 CT-S280

No.	Setting	OFF	ON
MSW1-1	Power ON Info	● Send	Not send
MSW1-2	Buffer Size	● 4K bytes	45 bytes
MSW1-3	Busy Condition	● Full/Err	Full
MSW1-4	Receive Error	● Print ?	No Print
MSW1-5	CR mode	● Ignored	LF
MSW1-6	Reserved	● Fixed	-
MSW1-7	DSR Signal	● Invalid	Valid
MSW1-8	Reserved	● Fixed	-
MSW2-1	Reserved	-	● Fixed
MSW2-2	Reserved	● Fixed	-
MSW2-3	Spool Print	● Invalid	Valid
MSW2-4	Full Col Print	● LineFeed	WaitData
MSW2-5	Resume aft PE	● Next	Top
MSW2-6	Reserved	-	● Fixed
MSW2-7	Reserved	● Fixed	-
MSW2-8	PNE Sensor	● Valid	Invalid
MSW3-1	Reserved	● Fixed	-
MSW3-2	Reserved	● Fixed	-
MSW3-3	Parallel 31 Pin	● Valid	Invalid
MSW3-4	Reserved	● Fixed	-
MSW3-5	Reserved	● Fixed	-
MSW3-6	Reserved	● Fixed	-
MSW3-7	CBM-270 Mode	Invalid	● Valid
MSW3-8	Resum Open Err	● Close	Command
MSW4-1	Reserved	● Fixed	-
MSW4-2	Reserved	● Fixed	-
MSW4-3	Reserved	● Fixed	-
MSW4-4	Reserved	● Fixed	-
MSW4-5	Reserved	● Fixed	-
MSW4-6	Reserved	● Fixed	-
MSW4-7	DC3 Function	● 2 Color	B/W Reverse
MSW4-8	Reserved	● Fixed	-

●: Factory setting

No.	Setting	Default	Set Values
MSW7-1	Baud Rate	9600bps	1200bps, 2400bps, 4800bps, 9600bps, 19200bps, 38400bps, 57600bps, 115200bps
MSW7-2	Data Length	8bits	7bits, 8bits
MSW7-3	Stop Bit	1bit	1bit, 2bits
MSW7-4	Parity	None	None, Odd, Even
MSW7-5	Flow Control	Xon/Xoff	DTR/DSR, Xon/Xoff
MSW7-6	Reserved	-	-
MSW7-7	Reserved	-	-
MSW8-1	Reserved	-	-
MSW8-2	Paper Type	1 Color	1 Color, 2 Color
MSW9-1	Code Page	PC437	PC437, Katakana, PC850, PC858, PC860, PC863, PC865, PC852, PC866, PC857, WindowsCode, Space page, PC864, ThaiCode18
MSW9-2	Int'Char Set	USA	USA, France, Germany, England, Denmark, Sweden, Italy, Spain, Japan, Norway, Denmark 2, Spain 2, Latin America, Korea
MSW9-3	Kanji	OFF	ON, OFF
MSW9-4	JIS/Shift JIS	JIS	JIS, Shift JIS
MSW10-1	Print Density	100%	70%,75%,80%,85%,90%,95%,100%,105%,110%,115%,120%,125%,130%,135%,140%
MSW10-2	Print Speed	Level9	Level1,Level2,Level3,Level4,Level5,Level6,Level7,Level8,Level9
MSW10-3	Reserved	-	-
MSW10-4	Reserved	-	-

#### 4.1.2 CT-S281

No.	Setting	OFF	ON
MSW1-1	Power ON Info	● Valid	Not send
MSW1-2	Buffer Size	● 4K bytes	45 bytes
MSW1-3	Busy Condition	● Full/Err	Full
MSW1-4	Receive Error	● Print "?"	No Print
MSW1-5	CR mode	● Ignored	LF
MSW1-6	Reserved	● Fixed	-
MSW1-7	DSR Signal	● Invalid	Valid
MSW1-8	Reserved	● Fixed	-
MSW2-1	Reserved	-	● Fixed
MSW2-2	Auto Cutter	Invalid	● Valid
MSW2-3	Spool Print	● Invalid	Valid
MSW2-4	Full Col Print	LineFeed	● WaitData
MSW2-5	Resume aft PE	● Next	Top
MSW2-6	Reserved	-	● Fixed
MSW2-7	Reserved	● Fixed	-
MSW2-8	PNE Sensor	Valid	● Invalid
MSW3-1	Resum Ctr Err	● Valid	Invalid
MSW3-2	Reserved	● Fixed	-
MSW3-3	Reserved	-	● Fixed
MSW3-4	Reserved	● Fixed	-
MSW3-5	Reserved	● Fixed	-
MSW3-6	Reserved	● Fixed	-
MSW3-7	CBM270 Mode	Invalid	● Valid
MSW3-8	Resum Open Err	● Close	Command
MSW4-1	P. Length Set	● Auto Measure	Command
MSW4-2	Power on TOF	● Invalid	Valid
MSW4-3	FEED&CUT at TOF	Invalid	● Valid
MSW4-4	Paper Select	● Thermal Roll	BM.P / Lbl.P
MSW4-5	Position detect	● Black Mark	Label
MSW4-6	C.Close Action	● Find TOF	Auto Measure
MSW4-7	Auto Paper Select	● Invalid	Valid
MSW4-8	Partial only	Invalid	● Valid
MSW5-1	Reserved	● Fixed	-
MSW5-2	Reserved	● Fixed	-
MSW5-3	USB Mode	Virtual COM	● Printer Class
MSW5-4	Reserved	● Fixed	-
MSW5-5	Reserved	● Fixed	-
MSW5-6	Auto Back Feed	● After Cut	Before Print
MSW5-7	Clear PNE LED	● Auto	Paper set
MSW5-8	Reserved	● Fixed	-

●: Factory setting

No.	Setting	Default	Set Values
MSW7-1	Baud Rate	9600bps	1200bps, 2400bps, 4800bps, 9600bps, 19200bps, 38400bps
MSW7-2	Data Length	8bits	7bits, 8bits
MSW7-3	Stop Bit	1bit	1bit, 2bits
MSW7-4	Parity	None	None, Odd, Even
MSW7-5	Flow Control	Xon/Xoff	DTR/DSR, Xon/Xoff
MSW7-6	Reserved	-	-
MSW7-7	VCom Protocol	PC setting	PC setting, DTR/DSR, XON/XOFF
MSW8-1	Reserved	-	-
MSW8-2	Paper Type	1 Color	1 Color, 2 Color
MSW9-1	Code Page	PC437	PC437, Katakana, PC850, PC858, PC860, PC863, PC865, PC852, PC866, PC857, WindowsCode, Space page, PC864, ThaiCode18
MSW9-2	Int'Char Set	USA	USA, France, Germany, England, Denmark, Sweden, Italy, Spain, Japan, Norway, Denmark 2, Spain 2, Latin America, Korea, Croatia, China
MSW9-3	Kanji	OFF	ON, OFF
MSW9-4	JIS/Shift JIS	JIS	JIS, Shift JIS
MSW10-1	Print Density	100%	70%,75%,80%,85%,90%,95%,100%,105%,110%,115%,120%,125%,130%,135%,140%
MSW10-2	Print Speed	Level9	Level1,Level2,Level3,Level4,Level5,Level6,Level7,Level8,Level9

<<Difference of MSW by the model>>

MSW4-4 and MSW4-5 are different by the model as follows.

Model	Standard		Black mark model		Label model	
MSW4-4	OFF	Thermal paper	ON	Black mark paper/ Label paper	ON	Black mark paper/ Label paper
MSW4-5	OFF	Black mark detection	OFF	Black mark detection	ON	Label detection

### 4.1.3 CT-S300

No.	Setting	OFF	ON
MSW1-1	Power ON Info	● Valid	Not send
MSW1-2	Buffer Size	● 4K bytes	45 bytes
MSW1-3	Busy Condition	● Full/Err	Full
MSW1-4	Receive Error	● Print ?	No Print
MSW1-5	CR mode	● Ignored	LF
MSW1-6	Reserved	● Fixed	-
MSW1-7	DSR Signal	● Invalid	Valid
MSW1-8	Init Signal	● Invalid	Valid
MSW2-1	Reserved	-	● Fixed
MSW2-2	Auto Cutter	Invalid	● Valid
MSW2-3	Spool Print	● Invalid	Valid
MSW2-4	Full Col Print	LineFeed	● WaitData
MSW2-5	Resume aft PE	● Next	Top
MSW2-6	Paper width	● 80mm	58mm
MSW2-7	Reserved	● Fixed	-
MSW2-8	PNE Sensor	● Valid	Invalid
MSW3-1	Resum Ctrr Err	● Valid	Invalid
MSW3-2	Resum Open Err	● close	command
MSW3-3	Parallel 31 Pin	● Valid	Invalid
MSW3-4	Paper Select	● Thermal	Black MK
MSW3-5	Column Number	● 48/32 col	42/30 col
MSW3-6	Reserved	● Fixed	-
MSW3-7	CBM1000 Mode	● Invalid	Valid
MSW3-8	Resum Open Err	● Close	command
MSW4-1	BM Measure	● Invalid	Valid
MSW4-2	BM Sensor	● surface	Back
MSW4-3	Reserved	● Fixed	-
MSW4-4	Reserved	● Fixed	-
MSW4-5	Reserved	● Fixed	-
MSW4-6	Reserved	● Fixed	-
MSW4-7	Reserved	● Fixed	-
MSW4-8	Partial only	Invalid	● Valid

●: Factory setting

#### <<Difference of MSW by the model>>

MSW3-4 and MSW4-2 are different by the model as follows.

Model	Standard model		Black mark model (Sensor at front side of paper)		Black mark model (Sensor at back side of paper)	
	OFF	Thermal paper	ON	Black mark	ON	Black mark
MSW3-4	OFF	Thermal paper	ON	Black mark	ON	Black mark
MSW4-2	OFF	Front surface	OFF	Front surface	ON	Back side

#### 4.1.4 CT-S310

No.	Setting	OFF	ON
MSW1-1	Power ON Info	● Valid	Not send
MSW1-2	Buffer Size	● 4K bytes	45 bytes
MSW1-3	Busy Condition	● Full/Err	Full
MSW1-4	Receive Error	● Print "?"	No Print
MSW1-5	CR mode	● Ignored	LF
MSW1-6	Reserved	● Fixed	-
MSW1-7	DSR Signal	● Invalid	Valid
MSW1-8	Init Signal	● Invalid	Valid
MSW2-1	Reserved	-	● Fixed
MSW2-2	Auto Cutter	Invalid	● Valid
MSW2-3	Spool Print	● Invalid	Valid
MSW2-4	Full Col Print	LineFeed	● WaitData
MSW2-5	Resume aft PE	● Next	Top
MSW2-6	Paper Width	● 80mm	58mm
MSW2-7	Reserved	● Fixed	-
MSW2-8	PNE Sensor	● Valid	Invalid
MSW3-1	Resum Ctrr Err	● Valid	Invalid
MSW3-2	Reserved	● Fixed	-
MSW3-3	Parallel 31 Pin	● Valid	Invalid
MSW3-4	Paper Select	● Thermal	Black MK
MSW3-5	Column Number	● 48/32Col	42/30Col
MSW3-6	Reserved	● Fixed	-
MSW3-7	CBM1000 Mode	● Invalid	Valid
MSW3-8	Resum Open Err	● Close	Command
MSW4-1	Auto Length	● Invalid	Auto
MSW4-2	BM sensor	● Surface	Back
MSW4-3	FEED&CUT at TOF	Invalid	● Valid
MSW4-4	Reserved	● Fixed	-
MSW4-5	Reserved	● Fixed	-
MSW4-6	Reserved	● Fixed	-
MSW4-7	Reserved	● Fixed	-
MSW4-8	Partial only	Invalid	● Valid
MSW5-1	Buzzer	● Auto	Invalid
MSW5-2	Reserved	● Fixed	-
MSW5-3	USB Mode	Virtual COM	● Printer Class
MSW5-4	Reserved	● Fixed	-
MSW5-5	Power OFF Info	● Valid	Invalid
MSW5-6	Reserved	● Fixed	-
MSW5-7	Clear PNE LED	● Auto	Paper set
MSW5-8	FAULT Output	● PE, PNE, Err	PE, Err

●: Factory setting



No.	Setting	Default	Set Values
MSW7-1	Baud Rate	9600bps	1200bps, 2400bps, 4800bps, 9600bps, 19200bps, 38400bps
MSW7-2	Data Length	8bits	7bits, 8bits
MSW7-3	Stop Bit	1bit	1bit, 2bits
MSW7-4	Parity	None	None, Odd, Even
MSW7-5	Flow Control	Xon/Xoff	DTR/DSR, Xon/Xoff
MSW7-6	Reserved	-	-
MSW7-7	VCom Protocol	PC setting	PC setting, DTR/DSR, XON/XOFF
MSW8-1	Reserved	-	-
MSW8-2	Paper Type	1 Color	1 Color, 2 Color
MSW9-1	Code Page	PC437	PC437,Katakana,PC850,PC858,PC860,PC863, PC865,PC852,PC866,PC857,WindowsCode, Space page, PC864,ThaiCode18
MSW9-2	Int'Char Set	USA	USA, France, Germany, England, Denmark, Sweden, Italy, Spain, Japan, Norway, Denmark 2, Spain 2, Latin America, Korea, Croatia, China
MSW9-3	Kanji	OFF	ON, OFF
MSW9-4	JIS/Shift JIS	JIS	JIS, Shift JIS
MSW10-1	Print Density	100%	70%, 75%, 80%, 85%, 90%, 95%, 100%, 105%, 110%, 115%, 120%, 125%, 130%, 135%, 140%
MSW10-2	Print Speed	Level9	Level1, Level2, Level3, Level4, Level5, Level6, Level7, Level8, Level9

<<Difference of MSW by the model>>

MSW3-4 and MSW4-2 are different by the model as follows.

Model	Standard model		Black mark model (Sensor at front side of paper)		Black mark model (Sensor at back side of paper)	
	OFF	Thermal paper	ON	Black mark	ON	Black mark
MSW3-4	OFF	Thermal paper	ON	Black mark	ON	Black mark
MSW4-2	OFF	Thermal paper	OFF	Front surface	ON	Back side

#### 4.1.5 CT-S310II

No.	Setting	OFF	ON
MSW1-1	Power ON Info	● Valid	Not send
MSW1-2	Buffer Size	● 4K bytes	45 bytes
MSW1-3	Busy Condition	● Full/Err	Full
MSW1-4	Receive Error	● Print ?	No Print
MSW1-5	CR mode	● Ignored	LF
MSW1-6	Reserved	● Fixed	-
MSW1-7	DSR Signal	● Invalid	Valid
MSW1-8	Reserved	● Fixed	-
MSW2-1	Reserved	-	● Fixed
MSW2-2	Auto Cutter	Invalid	● Valid
MSW2-3	Spool Print	● Invalid	Valid
MSW2-4	Full Col Print	● LineFeed	WaitData
MSW2-5	Resume aft PE	● Next	Top
MSW2-6	Reserved	● Fixed	-
MSW2-7	Reserved	● Fixed	-
MSW2-8	Reserved	● Fixed	-
MSW3-1	Resum Ctrr Err	● Valid	Invalid
MSW3-2	Reserved	● Fixed	-
MSW3-3	Reserved	● Fixed	-
MSW3-4	Reserved	● Fixed	-
MSW3-5	Reserved	● Fixed	-
MSW3-6	Reserved	● Fixed	-
MSW3-7	CBM1000 Mode	Invalid	● Valid
MSW3-8	Resum Open Err	● Close	Command
MSW4-1	Reserved	● Fixed	-
MSW4-2	Reserved	● Fixed	-
MSW4-3	Feed&Cut at TOF	Invalid	● Valid
MSW4-4	Reserved	● Fixed	-
MSW4-5	Reserved	● Fixed	-
MSW4-6	Reserved	● Fixed	-
MSW4-7	Reserved	● Fixed	-
MSW4-8	Partial only	Invalid	● Valid
MSW5-1	Buzzer	● Valid	Invalid
MSW5-2	Line Pitch	● 360	406
MSW5-3	USB Mode	Virtual COM	● Printer Class
MSW5-4	Reserved	● Fixed	-
MSW5-5	Reserved	● Fixed	-
MSW5-6	Reserved	● Fixed	-
MSW5-7	Reserved	● Fixed	-
MSW5-8	Reserved	● Fixed	-
MSW6-1	Act. For Driver	● Invalid	Valid
MSW6-2	Character space	● Invalid	Valid
MSW6-3	USB Power Save	Invalid	● Valid
MSW6-4	Reserved	● Fixed	-
MSW6-5	Reserved	● Fixed	-
MSW6-6	Reserved	● Fixed	-
MSW6-7	Reserved	● Fixed	-
MSW6-8	Reserved	● Fixed	-

●: Factory setting

No.	Setting	Default	Set Values
MSW7-1	Baud Rate	19200bps	1200 bps, 2400bps, 4800bps, 9600bps, 19200bps, 38400bps, 57600bps, 115200bps
MSW7-2	Data Length	8bits	7bits, 8bits
MSW7-3	Stop Bit	1bit	1bit, 2bits
MSW7-4	Parity	None	None, Odd, Even
MSW7-5	Flow Control	DTR/DSR	DTR/DSR, Xon/Xoff
MSW7-6	DMA control	Valid	Valid, Invalid
MSW7-7	VCom Protocol	PC setting	PC setting, DTR/DSR, XON/XOFF
MSW8-1	Print Width	576dots	576dots, 512dots, 420dots, 390dots, 384dots, 360dots, 546dots
MSW8-2	Reserved		
MSW8-3	Top Margin	11mm	11mm, 3mm, 4mm, 5mm, 6mm, 7mm, 8mm, 9mm, 10mm
MSW8-4	Line Gap Reduce	Invalid	Invalid, 3/4, 2/3, 1/2, 1/3, 1/4, 1/5, ALL
MSW8-5	Reduced Char V/H	100%/100%	100%/100%, 75%/100%, 50%/100%, 100%/75%, 75%/75%, 50%/75%
MSW8-6	Auto Side Shift	Invalid	Invalid, 1dot, 2dot, 3dot, 4dot, 5dot, 6dot, 7dot
MSW9-1	Code Page	PC437	PC437, Katakana, PC850, PC858, PC860, PC863, PC865, PC852, PC866, PC857, WindowsCode, Space page, PC864, ThaiCode18
MSW9-2	Int'Char Set	America	America, France, Germany, England, Denmark, Sweden, Italy, Spain, Japan, Norway, Denmark 2, Spain 2, Latin America, Korea, Croatia, China
MSW9-3	Kanji	OFF	ON, OFF
MSW9-4	JIS/Shift JIS	JIS	JIS, Shift JIS
MSW10-1	Print Density	100%	70%, 75%, 80%, 85%, 90%, 95%, 100%, 105%, 110%, 115%, 120%, 125%, 130%, 135%, 140%
MSW10-2	Print Speed	Level9	Level1, Level2, Level3, Level4, Level5, Level6, Level7, Level8, Level9
MSW10-3	Reserved		
MSW10-4	Reserved		
MSW10-5	Reserved		
MSW10-6	Buzzer Event	Not by C.Open	All Event/Error, Not by C.Open, Not by C.Open/PE

#### 4.1.6 CT-S2000

No.	Setting	OFF	ON
MSW1-1	Power ON Info	● Valid	Not send
MSW1-2	Buffer Size	● 4K bytes	45 bytes
MSW1-3	Busy Condition	● Full/Err	Full
MSW1-4	Receive Error	● Print ?	No Print
MSW1-5	CR mode	● Ignored	LF
MSW1-6	Reserved	● Fixed	-
MSW1-7	DSR Signal	● Invalid	Valid
MSW1-8	Init Signal	● Invalid	Valid
MSW2-1	Reserved	-	● Fixed
MSW2-2	Auto Cutter	Invalid	● Valid
MSW2-3	Spool Print	● Invalid	Valid
MSW2-4	Full Col Print	● LineFeed	WaitData
MSW2-5	Resume aft PE	● Next	Top
MSW2-6	Reserved	● Fixed	-
MSW2-7	Reserved	● Fixed	-
MSW2-8	PNE Sensor	● Valid	Invalid
MSW3-1	Resum Ctrr Err	● Valid	Invalid
MSW3-2	Reserved	● Fixed	-
MSW3-3	Parallel 31 Pin	● Valid	Invalid
MSW3-4	Reserved	● Fixed	-
MSW3-5	Reserved	● Fixed	-
MSW3-6	Reserved	● Fixed	-
MSW3-7	CBM1000 Mode	Invalid	● Valid
MSW3-8	Resum Open Err	● Close	Command
MSW4-1	BM Measure	● Invalid	Valid
MSW4-2	Reserved	● Fixed	-
MSW4-3	Feed&Cut at TOF	Invalid	● Valid
MSW4-4	Reserved	● Fixed	-
MSW4-5	Reserved	● Fixed	-
MSW4-6	Reserved	● Fixed	-
MSW4-7	Reserved	● Fixed	-
MSW4-8	Partial only	Invalid	● Valid
MSW5-1	Buzzer	● Valid	Invalid
MSW5-2	Line Pitch	● 360	406
MSW5-3	USB Mode	Virtual COM	● Printer Class
MSW5-4	Reserved	● Fixed	-
MSW5-5	Reserved	● Fixed	-
MSW5-6	Fine Printing	● Invalid	Valid
MSW5-7	No use	● Fixed	-
MSW5-8	No use	● Fixed	-

●: Factory setting

No.	Setting	Default	Set Values
MSW7-1	Baud Rate	19200bps	1200 bps, 2400bps, 4800bps, 9600bps, 19200bps, 38400bps, 57600bps, 115200bps
MSW7-2	Data Length	8bits	7bits, 8bits
MSW7-3	Stop Bit	1bit	1bit, 2bits
MSW7-4	Parity	None	None, Odd, Even
MSW7-5	Flow Control	DTR/DSR	DTR/DSR, Xon/Xoff
MSW7-6	DMA control	Valid	Valid, Invalid
MSW7-7	VCom Protocol	PC setting	PC setting, DTR/DSR, XON/XOFF
MSW8-1	Print Width	576dots	640dots, 576dots, 512dots, 436dots, 432dots, 420dots, 384dots, 360dots
MSW8-2	Paper Type	1 Color Normal	1 Color Normal, 1 Color BM, 1 Color Label, 2 Color Normal, 2 Color BM
MSW9-1	Code Page	PC437	PC437, Katakana, PC850, PC858, PC860, PC863, PC865, PC852, PC866, PC857, WindowsCode, Space page, PC864, ThaiCode18
MSW9-2	Int'Char Set	America	America, France, Germany, England, Denmark, Sweden, Italy, Spain, Japan, Norway, Denmark 2, Spain 2, Latin America, Korea, Croatia, China
MSW9-3	Kanji	OFF	ON, OFF
MSW9-4	JIS/Shift JIS	JIS	JIS, Shift JIS
MSW10-1	Print Density	100%	70%, 75%, 80%, 85%, 90%, 95%, 100%, 105%, 110%, 115%, 120%, 125%, 130%, 135%, 140%
MSW10-2	Print Speed	Level9	Level1, Level2, Level3, Level4, Level5, Level6, Level7, Level8, Level9
MSW10-3	ACK Timing	Before BUSY	Before Busy, Same Period, After Busy

<<Difference of MSW by the model>>

MSW4-4 and MSW4-5 are different by the model as follows.

Model	Standard		Black mark model		Label model	
MSW4-4	OFF	Thermal paper	ON	Black mark paper/ Label paper	ON	Black mark paper/ Label paper
MSW4-5	OFF	Black mark detection	OFF	Black mark detection	ON	Label detection

#### 4.1.7 CT-S4000

No.	Setting	OFF	ON
MSW1-1	Power ON Info	● Valid	Not send
MSW1-2	Buffer Size	● 4K bytes	45 bytes
MSW1-3	Busy Condition	● Full/Err	Full
MSW1-4	Receive Error	● Print "?"	No Print
MSW1-5	CR mode	● Ignored	LF
MSW1-6	Reserved	● Fixed	-
MSW1-7	DSR Signal	● Invalid	Valid
MSW1-8	Init Signal	● Invalid	Valid
MSW2-1	Reserved	-	● Fixed
MSW2-2	Auto Cutter	Invalid	● Valid
MSW2-3	Spool Print	● Invalid	Valid
MSW2-4	Full Col Print	● LineFeed	WaitData
MSW2-5	Resume aft PE	● Next	Top
MSW2-6	Reserved	● Fixed	-
MSW2-7	Reserved	● Fixed	-
MSW2-8	PNE Sensor	● Valid	Invalid
MSW3-1	Resum Ctr Err	● Valid	Invalid
MSW3-2	Reserved	● Fixed	-
MSW3-3	Parallel 31 Pin	● Valid	Invalid
MSW3-4	Reserved	● Fixed	-
MSW3-5	Reserved	● Fixed	-
MSW3-6	Reserved	● Fixed	-
MSW3-7	CBM1000 Mode	● Invalid	Valid
MSW3-8	Resum Open Err	● Close	Command
MSW4-1	P.Length Set	Auto Measure	Command
MSW4-2	Power on TOF	● Invalid	Valid
MSW4-3	FEED&CUT at TOF	Invalid	● Valid
MSW4-4	Paper Select	Thermal Roll	BM,P/Lbl.P
MSW4-5	Position Detect	Black Mark	Label
MSW4-6	Reserved	● Fixed	-
MSW4-7	Reserved	● Fixed	-
MSW4-8	Partial only	Invalid	● Valid
MSW5-1	Buzzer	Valid	● Invalid
MSW5-2	Line Pitch	● 1/360	1/406
MSW5-3	USB Mode	Virtual COM	● Printer Class
MSW5-4	Reserved	● Fixed	-
MSW5-5	Power OFF Info	● Invalid	Valid
MSW5-6	Reserved	● Fixed	-
MSW5-7	Reserved	● Fixed	-
MSW5-8	FAULT Output	● PE, PNE, Err	PE, Err

●: Factory setting

No.	Setting	Default	Set Values
MSW7-1	Baud Rate	19200bps	1200bps, 2400bps, 4800bps, 9600bps, 19200bps, 38400bps, 57600bps, 115200bps
MSW7-2	Data Length	8bits	7bits, 8bits
MSW7-3	Stop Bit	1bit	1bit, 2bits
MSW7-4	Parity	None	None, Odd, Even
MSW7-5	Flow Control	DTR/DSR	DTR/DSR, Xon/Xoff
MSW7-6	DMA control	Valid	Valid, Invalid
MSW7-7	VCom Protocol	PC setting	PC setting, DTR/DSR, XON/XOFF
MSW8-1	Print Width	832dots	832dots, 720dots, 660dots, 576dots, 512dots
MSW8-2	Paper Type	1 Color	1 Color, 2 Color
MSW9-1	Code Page	PC437	PC437, Katakana, PC850, PC858, PC860, PC863, PC865, PC852, PC866, PC857, WindowsCode, Space page, PC864, ThaiCode18
MSW9-2	Int'Char Set	America	America, France, Germany, England, Denmark, Sweden, Italy, Spain, Japan, Norway, Denmark 2, Spain 2, Latin America, Korea, Croatia, China
MSW9-3	Kanji	OFF	ON, OFF
MSW9-4	JIS/Shift JIS	JIS	JIS, Shift JIS
MSW10-1	Print Density	100%	70%, 75%, 80%, 85%, 90%, 95%, 100%, 105%, 110%, 115%, 120%, 125%, 130%, 135%, 140%
MSW10-2	Print Speed	Level9	Level1, Level2, Level3, Level4, Level5, Level6, Level7, Level8, Level9
MSW10-3	ACK Timing	Before BUSY	Before Busy, Same Period, After Busy
MSW10-4	NV User	192Kbytes	1Kbytes, 64Kbytes, 128Kbytes, 192Kbytes
MSW10-5	NV Graphic	384Kbytes	0byte, 64Kbytes, 128Kbytes, 192Kbytes, 256Kbytes, 320Kbytes, 384Kbytes

<<Difference of MSW by the model>>

MSW4-4 and MSW4-5 are different by the model as follows.

Model	Standard		Black mark model		Label model	
MSW4-4	OFF	Thermal paper	ON	Black mark paper/ Label paper	ON	Black mark paper/ Label paper
MSW4-5	OFF	Black mark detection	OFF	Black mark detection	ON	Label detection

#### 4.1.8 CT-S801/851

No.	Setting	OFF	ON
MSW1-1	Power ON Info	● Valid	Not send
MSW1-2	Buffer Size	● 4K bytes	45 bytes
MSW1-3	Busy Condition	● Full/Err	Full
MSW1-4	Receive Error	● Print ?	No Print
MSW1-5	CR mode	● Ignored	LF
MSW1-6	Reserved	● Fixed	-
MSW1-7	DSR Signal	● Invalid	Valid
MSW1-8	Init Signal	● Invalid	Valid
MSW2-1	Reserved	-	● Fixed
MSW2-2	Auto Cutter	Invalid	● Valid
MSW2-3	Spool Print	● Invalid	Valid
MSW2-4	Full Col Print	● LineFeed	WaitData
MSW2-5	Resume aft PE	● Next	Top
MSW2-6	Reserved	● Fixed	-
MSW2-7	Reserved	● Fixed	-
MSW2-8	PNE Sensor	● Valid	Invalid
MSW3-1	Resum Ctrr Err	● Valid	Invalid
MSW3-2	PE signal by PNE	● Fixed	-
MSW3-3	Parallel 31 Pin	● Valid	Invalid
MSW3-4	Reserved	● Fixed	-
MSW3-5	Reserved	● Fixed	-
MSW3-6	Reserved	● Fixed	-
MSW3-7	CBM1000 Mode	Invalid	● Valid
MSW3-8	Resum Open Err	● Close	Command
MSW4-1	Reserved	● Fixed	-
MSW4-2	Reserved	● Fixed	-
MSW4-3	Feed&Cut at TOF	Invalid	● Valid
MSW4-4	Reserved	● Fixed	-
MSW4-5	Reserved	● Fixed	-
MSW4-6	Reserved	● Fixed	-
MSW4-7	Reserved	● Fixed	-
MSW4-8	Partial only	Invalid	● Valid
MSW5-1	Buzzer	● Valid	Invalid
MSW5-2	Line Pitch	● 360	406
MSW5-3	USB Mode	Virtual COM	● Printer Class
MSW5-4	Reserved	● Fixed	-
MSW5-5	Reserved	● Fixed	-
MSW5-6	Reserved	● Fixed	-
MSW5-7	Reserved	● Fixed	-
MSW5-8	Reserved	● Fixed	-
MSW6-1	Act. For Driver	● Invalid	Valid
MSW6-2	Character space	Invalid	● Valid
MSW6-3	Reserved	● Fixed	-
MSW6-4	Reserved	● Fixed	-
MSW6-5	Reserved	● Fixed	-
MSW6-6	Reserved	● Fixed	-
MSW6-7	Reserved	● Fixed	-
MSW6-8	Reserved	● Fixed	-

●: Factory setting



No.	Setting	Default	Set Values
MSW7-1	Baud Rate	19200bps	1200 bps, 2400bps, 4800bps, 9600bps, 19200bps, 38400bps, 57600bps, 115200bps
MSW7-2	Data Length	8bits	7bits, 8bits
MSW7-3	Stop Bit	1bit	1bit, 2bits
MSW7-4	Parity	None	None, Odd, Even
MSW7-5	Flow Control	DTR/DSR	DTR/DSR, Xon/Xoff
MSW7-6	DMA control	Valid	Valid, Invalid
MSW7-7	VCom Protocol	PC setting	PC setting, DTR/DSR, XON/XOFF
MSW8-1	Print Width	576dots	640dots, 576dots, 512dots, 436dots, 432dots, 420dots, 384dots, 360dots
MSW8-2	Paper Type	1 Color Normal	1 Color Normal, 2 Color Normal
MSW9-1	Code Page	PC437	PC437, Katakana, PC850, PC858, PC860, PC863, PC865, PC852, PC866, PC857, WindowsCode, Space page, PC864, ThaiCode18
MSW9-2	Int'Char Set	America	America, France, Germany, England, Denmark, Sweden, Italy, Spain, Japan, Norway, Denmark 2, Spain 2, Latin America, Korea, Croatia, China
MSW9-3	Kanji	OFF	ON, OFF
MSW9-4	JIS/Shift JIS	JIS	JIS, Shift JIS
MSW9-6	LCD Char Set	English	English, Français, Deutsch, Italiano, Español, Japanese, Chinese
MSW9-7	LCD Ext Char	Invalid	Invalid, Valid
MSW9-8	Bklight Auto Off	Never	Never, 30seconds, 5munites
MSW10-1	Print Density	100%	70%, 75%, 80%, 85%, 90%, 95%, 100%, 105%, 110%, 115%, 120%, 125%, 130%, 135%, 140%
MSW10-2	Print Speed	Level9	Level1, Level2, Level3, Level4, Level5, Level6, Level7, Level8, Level9
MSW10-3	ACK Timing	Before BUSY	Before Busy, Same Period, After Busy
MSW10-6	Buzzer Sound	Tone 2	Tone 1, Tone 2, Tone 3, Tone 4
MSW10-7	Key Lock	Invalid	Invalid, Valid
MSW10-8	LCD Direction	Normal	Normal, Inverted

<<Difference of MSW by the model>>

MSW4-4 and MSW4-5 are different by the model as follows.

Model	Standard		Black mark model		Label model	
MSW4-4	OFF	Thermal paper	ON	Black mark paper/ Label paper	ON	Black mark paper/ Label paper
MSW4-5	OFF	Black mark detection	OFF	Black mark detection	ON	Label detection

#### 4.1.9 CT-S601/651

No.	Setting	OFF	ON
MSW1-1	Power ON Info	● Valid	Not send
MSW1-2	Buffer Size	● 4K bytes	45 bytes
MSW1-3	Busy Condition	● Full/Err	Full
MSW1-4	Receive Error	● Print ?	No Print
MSW1-5	CR mode	● Ignored	LF
MSW1-6	Reserved	● Fixed	-
MSW1-7	DSR Signal	● Invalid	Valid
MSW1-8	Init Signal	● Invalid	Valid
MSW2-1	Reserved	-	● Fixed
MSW2-2	Auto Cutter	Invalid	● Valid
MSW2-3	Spool Print	● Invalid	Valid
MSW2-4	Full Col Print	● LineFeed	WaitData
MSW2-5	Resume aft PE	● Next	Top
MSW2-6	Reserved	● Fixed	-
MSW2-7	Reserved	● Fixed	-
MSW2-8	PNE Sensor	● Valid	Invalid
MSW3-1	Resum Ctrr Err	● Valid	Invalid
MSW3-2	PE signal by PNE	● Fixed	-
MSW3-3	Parallel 31 Pin	● Valid	Invalid
MSW3-4	Reserved	● Fixed	-
MSW3-5	Reserved	● Fixed	-
MSW3-6	Reserved	● Fixed	-
MSW3-7	CBM1000 Mode	Invalid	● Valid
MSW3-8	Resum Open Err	● Close	Command
MSW4-1	Reserved	● Fixed	-
MSW4-2	Reserved	● Fixed	-
MSW4-3	Feed&Cut at TOF	Invalid	● Valid
MSW4-4	Reserved	● Fixed	-
MSW4-5	Reserved	● Fixed	-
MSW4-6	Reserved	● Fixed	-
MSW4-7	Reserved	● Fixed	-
MSW4-8	Partial only	Invalid	● Valid
MSW5-1	Buzzer	● Valid	Invalid
MSW5-2	Line Pitch	● 360	406
MSW5-3	USB Mode	Virtual COM	● Printer Class
MSW5-4	Reserved	● Fixed	-
MSW5-5	Reserved	● Fixed	-
MSW5-6	Reserved	● Fixed	-
MSW5-7	Reserved	● Fixed	-
MSW5-8	Reserved	● Fixed	-
MSW6-1	Act. For Driver	● Invalid	Valid
MSW6-2	Character space	Invalid	● Valid
MSW6-3	Reserved	● Fixed	-
MSW6-4	Reserved	● Fixed	-
MSW6-5	Reserved	● Fixed	-
MSW6-6	Reserved	● Fixed	-
MSW6-7	Reserved	● Fixed	-
MSW6-8	Reserved	● Fixed	-

●: Factory setting

No.	Setting	Default	Set Values
MSW7-1	Baud Rate	19200bps	1200 bps, 2400bps, 4800bps, 9600bps, 19200bps, 38400bps, 57600bps, 115200bps
MSW7-2	Data Length	8bits	7bits, 8bits
MSW7-3	Stop Bit	1bit	1bit, 2bits
MSW7-4	Parity	None	None, Odd, Even
MSW7-5	Flow Control	DTR/DSR	DTR/DSR, Xon/Xoff
MSW7-6	DMA control	Valid	Valid, Invalid
MSW7-7	VCom Protocol	PC setting	PC setting, DTR/DSR, XON/XOFF
MSW8-1	Print Width	576dots	640dots, 576dots, 512dots, 436dots, 432dots, 420dots, 384dots, 360dots
MSW8-2	Paper Type	1 Color Normal	1 Color Normal, 2 Color Normal
MSW9-1	Code Page	PC437	PC437, Katakana, PC850, PC858, PC860, PC863, PC865, PC852, PC866, PC857, WindowsCode, Space page, PC864, ThaiCode18
MSW9-2	Int'Char Set	America	America, France, Germany, England, Denmark, Sweden, Italy, Spain, Japan, Norway, Denmark 2, Spain 2, Latin America, Korea, Croatia, China
MSW9-3	Kanji	OFF	ON, OFF
MSW9-4	JIS/Shift JIS	JIS	JIS, Shift JIS
MSW10-1	Print Density	100%	70%, 75%, 80%, 85%, 90%, 95%, 100%, 105%, 110%, 115%, 120%, 125%, 130%, 135%, 140%
MSW10-2	Print Speed	Level9	Level1, Level2, Level3, Level4, Level5, Level6, Level7, Level8, Level9
MSW10-3	ACK Timing	Before BUSY	Before Busy, Same Period, After Busy
MSW10-6	Buzzer Sound	Tone 2	Tone 1, Tone 2, Tone 3, Tone 4

<<Difference of MSW by the model>>

MSW4-4 and MSW4-5 are different by the model as follows.

Model	Standard		Black mark model		Label model	
MSW4-4	OFF	Thermal paper	ON	Black mark paper/ Label paper	ON	Black mark paper/ Label paper
MSW4-5	OFF	Black mark detection	OFF	Black mark detection	ON	Label detection

#### 4.1.10 BD2-2220

No.	Setting	OFF	ON
MSW1-1	Power ON Info	● Valid	Not send
MSW1-2	Buffer Size	● 4K bytes	45 bytes
MSW1-3	Busy Condition	● Full/Err	Full
MSW1-4	Receive Error	● Print ?	No Print
MSW1-5	CR mode	● Ignored	LF
MSW1-6	Reserved	● Fixed	-
MSW1-7	DSR Signal	● Invalid	Valid
MSW1-8	Reserved	● Fixed	-
MSW2-1	Reserved	-	● Fixed
MSW2-2	Reserved	-	● Fixed
MSW2-3	Spool Print	● Invalid	Valid
MSW2-4	Full Col Print	● LineFeed	WaitData
MSW2-5	Resume aft. H.D(*)	● Next	Top
MSW2-6	Reserved	-	● Fixed
MSW2-7	Reserved	● Fixed	-
MSW2-8	Reserved	● Fixed	-
MSW3-1	Resum Ctr Err	● Valid	Invalid
MSW3-2	Reserved	● Fixed	-
MSW3-3	Reset	● Valid	Invalid
MSW3-4	Reserved	● Fixed	-
MSW3-5	Reserved	● Fixed	-
MSW3-6	Reserved	● Fixed	-
MSW3-7	Reserved	● Fixed	-
MSW3-8	Resum H.U Err(*)	Close	● Command

●: Factory setting

\*This function is enabled for platen close/open operation when LT-2x21 is used.

#### 4.1.11 PMU2XXX

No.	Setting	OFF	ON
MSW1-1	Power ON Info	● Valid	Not send
MSW1-2	Buffer Size	● 4K bytes	45 bytes
MSW1-3	Busy Condition	● Full/Err	Full
MSW1-4	Receive Error	● Print "?"	No Print
MSW1-5	CR mode	● Ignored	LF
MSW1-6	Reserved	● Fixed	-
MSW1-7	DSR Signal	● Invalid	Valid
MSW1-8	Reserved	● Fixed	-
MSW2-1	Reserved	-	● Fixed
MSW2-2	Auto Cutter	Invalid	● Valid
MSW2-3	Spool Print	● Invalid	Valid
MSW2-4	Full Col Print	● LineFeed	● WaitData
MSW2-5	Resume aft PE	● Print next line	Print top line
MSW2-6	Paper Width	● 80mm	58(60)mm
MSW2-7	Reserved	● Fixed	-
MSW2-8	PNE Sensor	Valid	● Invalid
MSW3-1	Resum Ctrr Err	● Valid	Invalid
MSW3-2	Reserved	● Fixed	-
MSW3-3	Parallel 31 Pin	● Valid	Invalid
MSW3-4	Paper Select	● Thermal	Black MK
MSW3-5	Reserved	● Fixed	-
MSW3-6	Reserved	● Fixed	-
MSW3-7	Reserved	● Fixed	-
MSW3-8	Resum Open Err	● Close	Command
MSW4-1	Auto Length	● Invalid	Auto
MSW4-2	Auto Loading	Invalid	● Valid
MSW4-3	FEED&CUT at TOF	Invalid	● Valid
MSW4-4	Base style	● PMU2xx0/2	PMU2xx1
MSW4-5	Mechanism mounted	● LT-23xx	LT-22xx
MSW4-6	Reserved	● Fixed	-
MSW4-7	Reserved	● Fixed	-
MSW4-8	Partial only	● Invalid	Valid
MSW5-1	Reserved	● Fixed	-
MSW5-2	Reserved	● Fixed	-
MSW5-3	Reserved	● Fixed	-
MSW5-4	Reserved	● Fixed	-
MSW5-5	Reserved	● Fixed	-
MSW5-6	Speed / Quality	Quality	● Speed
MSW5-7	Reserved	● Fixed	-
MSW5-8	Reserved	● Fixed	-

●: Factory setting

No.	Setting	Default	Set Values
MSW7-1	Baud Rate	9600bps	1200bps, 2400bps, 4800bps, 9600bps, 19200bps, 38400bps, 57600bps, 115200bps
MSW7-2	Data Length	8bits	7bits, 8bits
MSW7-3	Stop Bit	1bit	1bit, 2bits
MSW7-4	Parity	None	None, Odd, Even
MSW7-5	Flow Control	DTR/DSR	DTR/DSR, Xon/Xoff
MSW7-6	Reserved	-	-
MSW7-7	Reserved	-	-
MSW9-1	Code Page	PC437	PC437, Katakana, PC850, PC858, PC860, PC863, PC865, PC852, PC866, PC857, WindowsCode, Space page, PC864, ThaiCode18
MSW9-2	Int'Char Set	USA	USA, France, Germany, England, Denmark, Sweden, Italy, Spain, Japan, Norway, Denmark 2, Spain 2, Latin America, Korea, Croatia, China
MSW9-3	Kanji	OFF	ON, OFF
MSW9-4	JIS/Shift JIS	JIS	JIS, Shift JIS
MSW10-1	Print Density	100%	70%, 75%, 80%, 85%, 90%, 95%, 100%, 105%, 110%, 115%, 120%, 125%, 130%, 135%, 140%
MSW10-2	Print Speed	Level9	Level1, Level2, Level3, Level4, Level5, Level6, Level7, Level8, Level9
MSW10-3	ACK Timing	Before BUSY	Before Busy, Same Period, After Busy

<<Difference of MSW by the model>>

MSW2-6, MSW4-4 and MSW4-5 are different by the model as follows.

Model	MSW2-6 Paper width		MSW4-4 Base style		MSW4-5 Used mechanism	
PMU2200 (A)	ON	58(60)mm	OFF	PMU2XX0/2XX2	ON	LT-22XX
PMU2210 (A)	ON	58(60)mm	OFF	PMU2XX0/2XX2	ON	LT-22XX
PMU2211 (A)	ON	58(60)mm	ON	PMU2XX1	ON	LT-22XX
PMU2202 (A)	ON	58(60)mm	OFF	PMU2XX0/2XX2	ON	LT-22XX
PMU2212 (A)	ON	58(60)mm	OFF	PMU2XX0/2XX2	ON	LT-22XX
PMU2310 (A)	ON	58(60)mm	OFF	PMU2XX0/2XX2	OFF	LT-23XX
PMU2300 (A)	OFF	80mm	OFF	PMU2XX0/2XX2	OFF	LT-23XX
PMU2301 (A)	OFF	80mm	ON	PMU2XX1	OFF	LT-23XX
PMU2302 (A)	OFF	80mm	OFF	PMU2XX0/2XX2	OFF	LT-23XX

MSW3-4 is different by the model as follows.

Model	Standard model		Black mark model	
MSW3-4	OFF	Thermal paper	ON	Black mark paper

#### 4.1.12 PMU2XXXII

No.	Setting	OFF	ON
MSW1-1	Power ON Info	● Valid	Not send
MSW1-2	Buffer Size	● 4K bytes	45 bytes
MSW1-3	Busy Condition	● Full/Err	Full
MSW1-4	Receive Error	● Print "?"	No Print
MSW1-5	CR mode	● Ignored	LF
MSW1-6	Reserved	● Fixed	-
MSW1-7	DSR Signal	● Invalid	Valid
MSW1-8	Reserved	● Fixed	-
MSW2-1	Reserved	-	● Fixed
MSW2-2	Auto Cutter	Invalid	● Valid
MSW2-3	Spool Print	● Invalid	Valid
MSW2-4	Full Col Print	● LineFeed	● WaitData
MSW2-5	Resume aft PE	● Print next line	Print top line
MSW2-6	Paper Width	● 80mm	58(60)mm
MSW2-7	Reserved	● Fixed	-
MSW2-8	PNE Sensor	Valid	● Invalid
MSW3-1	Resum Ctrr Err	● Valid	Invalid
MSW3-2	Reserved	● Fixed	-
MSW3-3	Parallel 31 Pin	● Valid	Invalid
MSW3-4	Paper Select	● Thermal	Black MK
MSW3-5	Column Number	● 48/32Col	42/30Col
MSW3-6	Reserved	● Fixed	-
MSW3-7	CBM1000 Mode	Invalid	● Valid
MSW3-8	Resum Open Err	● Close	Command
MSW4-1	Auto Length	● Invalid	Auto
MSW4-2	Auto Loading	Invalid	● Valid
MSW4-3	FEED&CUT at TOF	Invalid	● Valid
MSW4-4	Base style	● PMU2xx0/2	PMU2xx1
MSW4-5	Mechanism mounted	● LT-23xx	LT-22xx
MSW4-6	Reserved	● Fixed	-
MSW4-7	Reserved	● Fixed	-
MSW4-8	Partial only	● Invalid	Valid
MSW5-1	Reserved	● Fixed	-
MSW5-2	Reserved	● Fixed	-
MSW5-3	USB Mode	Virtual COM	● Printer Class
MSW5-4	Reserved	● Fixed	-
MSW5-5	Reserved	● Fixed	-
MSW5-6	Speed / Quality	● Quality	Speed
MSW5-7	Reserved	● Fixed	-
MSW5-8	Reserved	● Fixed	-

●: Factory setting

No.	Setting	Default	Set Values
MSW7-1	Baud Rate	9600bps	1200bps, 2400bps, 4800bps, 9600bps, 19200bps, 38400bps, 57600bps, 115200bps
MSW7-2	Data Length	8bits	7bits, 8bits
MSW7-3	Stop Bit	1bit	1bit, 2bits
MSW7-4	Parity	None	None, Odd, Even
MSW7-5	Flow Control	DTR/DSR	DTR/DSR, Xon/Xoff
MSW7-6	Reserved	-	-
MSW7-7	Reserved	-	-
MSW9-1	Code Page	PC437	PC437, Katakana, PC850, PC858, PC860, PC863, PC865, PC852, PC866, PC857, WindowsCode, Space page, PC864, ThaiCode18
MSW9-2	Int'Char Set	USA	USA, France, Germany, England, Denmark, Sweden, Italy, Spain, Japan, Norway, Denmark 2, Spain 2, Latin America, Korea
MSW9-3	Kanji	OFF	ON, OFF
MSW9-4	JIS/Shift JIS	JIS	JIS, Shift JIS
MSW10-1	Print Density	100%	70%, 75%, 80%, 85%, 90%, 95%, 100%, 105%, 110%, 115%, 120%, 125%, 130%, 135%, 140%
MSW10-2	Print Speed	Level9	Level1, Level2, Level3, Level4, Level5, Level6, Level7, Level8, Level9

<<Difference of MSW by the model>>

MSW2-6, MSW4-4 and MSW4-5 are different by the model as follows

Model	MSW2-6 Paper width		MSW4-4 Base style		MSW4-5 Used mechanism	
PMU2200 II(A)	ON	58(60)mm	OFF	PMU2XX0/2XX2	ON	LT-22XX
PMU2210 II(A)	ON	58(60)mm	OFF	PMU2XX0/2XX2	ON	LT-22XX
PMU2211 II(A)	ON	58(60)mm	ON	PMU2XX1	ON	LT-22XX
PMU2202 II(A)	ON	58(60)mm	OFF	PMU2XX0/2XX2	ON	LT-22XX
PMU2212 II(A)	ON	58(60)mm	OFF	PMU2XX0/2XX2	ON	LT-22XX
PMU2310 II(A)	ON	58(60)mm	OFF	PMU2XX0/2XX2	OFF	LT-23XX
PMU2300 II(A)	OFF	80mm	OFF	PMU2XX0/2XX2	OFF	LT-23XX
PMU2301 II(A)	OFF	80mm	ON	PMU2XX1	OFF	LT-23XX
PMU2302 II(A)	OFF	80mm	OFF	PMU2XX0/2XX2	OFF	LT-23XX

MSW3-4 is different by the model as follows.

Model	Standard model		Black mark model	
MSW3-4	OFF	Thermal paper	ON	Black mark paper



#### 4.1.13 PMU2300III

No.	Setting	OFF	ON
MSW1-1	Power ON Info	● Valid	Not send
MSW1-2	Buffer Size	● 4K bytes	45 bytes
MSW1-3	Busy Condition	● Full/Err	Full
MSW1-4	Receive Error	● Print "?"	No Print
MSW1-5	CR mode	● Ignored	LF
MSW1-6	Reserved	● Fixed	-
MSW1-7	DSR Signal	● Invalid	Valid
MSW1-8	Reserved	● Fixed	-
MSW2-1	Reserved	-	● Fixed
MSW2-2	Auto Cutter	Invalid	● Valid
MSW2-3	Spool Print	● Invalid	Valid
MSW2-4	Full Col Print	● LineFeed	● WaitData
MSW2-5	Resume aft PE	● Print next line	Print top line
MSW2-6	Paper Width	● 80mm	58(60)mm
MSW2-7	Reserved	● Fixed	-
MSW2-8	PNE Sensor	Valid	● Invalid
MSW3-1	Resum Ctrr Err	● Valid	Invalid
MSW3-2	Reserved	● Fixed	-
MSW3-3	Parallel 31 Pin	● Valid	Invalid
MSW3-4	Paper Select	● Thermal	Black MK
MSW3-5	Column Number	● 48/32Col	42/30Col
MSW3-6	Reserved	● Fixed	-
MSW3-7	CBM1000 Mode	Invalid	● Valid
MSW3-8	Resum Open Err	● Close	Command
MSW4-1	Auto Length	● Invalid	Auto
MSW4-2	Auto Loading	Invalid	● Valid
MSW4-3	FEED&CUT at TOF	Invalid	● Valid
MSW4-4	Reserved	● Fixed	-
MSW4-5	Reserved	● Fixed	-
MSW4-6	Reserved	● Fixed	-
MSW4-7	Reserved	● Fixed	-
MSW4-8	Partial only	● Invalid	Valid
MSW5-1	Reserved	● Fixed	-
MSW5-2	Reserved	● Fixed	-
MSW5-3	USB Mode	Virtual COM	● Printer Class
MSW5-4	Reserved	● Fixed	-
MSW5-5	Reserved	● Fixed	-
MSW5-6	Speed / Quality	● Quality	Speed
MSW5-7	Reserved	● Fixed	-
MSW5-8	Reserved	● Fixed	-

●: Factory setting

No.	Setting	Default	Set Values
MSW7-1	Baud Rate	9600bps	1200bps, 2400bps, 4800bps, 9600bps, 19200bps, 38400bps, 57600bps, 115200bps
MSW7-2	Data Length	8bits	7bits, 8bits
MSW7-3	Stop Bit	1bit	1bit, 2bits
MSW7-4	Parity	None	None, Odd, Even
MSW7-5	Flow Control	DTR/DSR	DTR/DSR, Xon/Xoff
MSW7-6	Reserved	-	-
MSW7-7	Reserved	-	-
MSW9-1	Code Page	PC437	PC437, Katakana, PC850, PC858, PC860, PC863, PC865, PC852, PC866, PC857, WindowsCode, Space page, PC864, ThaiCode18
MSW9-2	Int'Char Set	USA	USA, France, Germany, England, Denmark, Sweden, Italy, Spain, Japan, Norway, Denmark 2, Spain 2, Latin America, Korea
MSW9-3	Kanji	OFF	ON, OFF
MSW9-4	JIS/Shift JIS	JIS	JIS, Shift JIS
MSW10-1	Print Density	100%	70%, 75%, 80%, 85%, 90%, 95%, 100%, 105%, 110%, 115%, 120%, 125%, 130%, 135%, 140%
MSW10-2	Print Speed	Level9	Level1, Level2, Level3, Level4, Level5, Level6, Level7, Level8, Level9

No.	Setting	OFF	ON
MSW11-1	Presenter	Invalid	Valid
MSW11-2	Retract Function	● Invalid	Valid
MSW11-3	Retract Direction	● Rear	Front
MSW11-4	Store and eject	Invalid	● Valid
MSW11-5	No print with paper	Invalid	● Valid
MSW11-6	Min Receipt Length	● 75mm	120mm
MSW11-7	Reserved	● Fixed	-
MSW11-8	Reserved	● Fixed	-
MSW12-1	Bezel Function <sup>*5</sup>	Invalid	Valid
MSW12-2	LED Control	Invalid	● Valid
MSW12-3	Reserved	● Fixed	-
MSW12-4	Reserved	● Fixed	-
MSW12-5	Show Error by LED	● Invalid	Valid
MSW12-6	No print with paper	Invalid	● Valid
MSW12-7	Reserved	● Fixed	-
MSW12-8	Reserved	● Fixed	-

●: Factory setting

<<Difference of MSW by the model>>

MSW11-1 and MSW12-1 are different by the model as follows.

<b>Model</b>	<b>MSW11-1 Presenter</b>		<b>MSW12-1 Bezel</b>	
PMU2300III SN	OFF	Invalid	OFF	Invalid
PMU2300III SB	OFF	Invalid	ON	Valid
PMU2300III PN	ON	Valid	OFF	Invalid
PMU2300III PB	ON	Valid	ON	Valid

MSW3-4 is different by the model as follows.

<b>Model</b>	<b>Standard model</b>		<b>Black mark model</b>	
MSW3-4	OFF	Thermal paper	ON	Black mark paper

#### 4.1.14 CT-P29x series

No.	Setting	OFF	ON
MSW1-1	Power ON Info	● Valid	Not send
MSW1-2	Buffer Size *1	● 4K bytes	45 bytes
MSW1-3	Busy Condition	● Full/Err	Full
MSW1-4	Receive Error	● Print "?"	No Print
MSW1-5	CR mode	● Ignored	LF
MSW1-6	Reserved	● Fixed	-
MSW1-7	DSR Signal	● Invalid	Valid
MSW1-8	Reserved	● Fixed	-
MSW2-1	Reserved	-	● Fixed
MSW2-2	Auto Cutter	Invalid	● Valid
MSW2-3	Spool Print	● Invalid	Valid
MSW2-4	Full Col Print	● LineFeed	WaitData
MSW2-5	Resume aft PE	● Print next line	Print top line
MSW2-6	Reserved *3	-	-
MSW2-7	Reserved	● Fixed	-
MSW2-8	Reserved	-	● Fixed
MSW3-1	Resum Ctrr Err	● Valid	Invalid
MSW3-2	Reserved	● Fixed	-
MSW3-3	Parallel 31 Pin	● Valid	Invalid
MSW3-4	Reserved	● -	-
MSW3-5	Column Number *2	● 48(CT-P292,3) ● 34(CT-P290,1)	32 32
MSW3-6	Reserved	● Fixed	-
MSW3-7	CBM1000 Mode	● Invalid	Valid
MSW3-8	Resum Open Err	● Close	Command
MSW4-1	Reserved	-	● Fixed
MSW4-2	Reserved	-	● Fixed
MSW4-3	FEED&CUT at TOF	Invalid	● Valid
MSW4-4	Reserved	● Fixed	-
MSW4-5	Reserved	● Fixed	-
MSW4-6	Reserved	● Fixed	-
MSW4-7	Reserved	● Fixed	-
MSW4-8	Partial only	● Invalid	Valid
MSW5-1	Reserved	● Fixed	-
MSW5-2	Reserved	● Fixed	-
MSW5-3	Reserved	● Fixed	-
MSW5-4	Reserved	● Fixed	-
MSW5-5	Reserved	● Fixed	-
MSW5-6	Speed / Quality	Speed	● Quality
MSW5-7	Reserved	● Fixed	-
MSW5-8	Reserved	● Fixed	-

●: Factory setting

MSW2-2 is effective when DSW-1 is set at ON (Valid).

\*1: If interface is parallel or USB, Buffer size is fixed at 4k bytes regardless of this setting.

\*2: Depending on DSW-6 setting

\*3: Depending on DSW-6 setting

No.	Setting	Default	Set Values
MSW7-1	Baud Rate	9600bps	1200bps, 2400bps, 4800bps, 9600bps, 19200bps, 38400bps, 57600bps, 115200bps
MSW7-2	Data Length	8bits	7bits, 8bits
MSW7-3	Stop Bit	1bit	1bit, 2bits
MSW7-4	Parity	None	None, Odd, Even
MSW7-5	Flow Control	DTR/DSR	DTR/DSR, Xon/Xoff
MSW7-6	Reserved	-	-
MSW7-7	VCom Protocol	PC setting	PC setting, DTR/DSR, XON/XOFF
MSW9-1	Code Page	PC437	PC437, Katakana, PC850, PC858, PC860, PC863, PC865, PC852, PC866, PC857, WindowsCode, Space page, PC864, ThaiCode18
MSW9-2	Int'Char Set	USA	USA, France, Germany, England, Denmark, Sweden, Italy, Spain, Japan, Norway, Denmark 2, Spain 2, Latin America, Korea
MSW9-3	Kanji	OFF	ON, OFF
MSW9-4	JIS/Shift JIS	JIS	JIS, Shift JIS
MSW10-1	Print Density	100%	70%, 75%, 80%, 85%, 90%, 95%, 100%, 105%, 110%, 115%, 120%, 125%, 130%, 135%, 140%
MSW10-2	Print Speed	Level9	Level1, Level2, Level3, Level4, Level5, Level6, Level7, Level8, Level9
MSW10-3	Reserved	-	-

## 4.2 Details of Memory Switches

This section describes the function of memory switch.

Some MSW may not be set or some values may not be selected depending on the model used. For the MSW and value that can be set or selected with the model you are using, refer to the operation manual or the like.

### 4.2.1 MSW1

●**MSW1-1:** Setting the power ON notify

[Outline] At power ON, to notify the host of the printer power ON, printer can send to host 3 byte power ON notify status data ( 3BH 31H 00H).

Set to enable/disable for sending the power ON notify status data.

	<b>OFF(0)</b>	<b>ON(1)</b>
Power ON Info	Valid	Not send

ON (1) OPERATION:

Function to notify power ON is disabled, sending no status to host.

OFF (0) OPERATION:

Function to notify power ON is enabled, sending status to host.

●**MSW1-2:** Input buffer

[Outline] Select the input buffer (receive buffer) size.

	<b>OFF(0)</b>	<b>ON(1)</b>
Buffer Size	4Kbytes	45bytes

ON (1) OPERATION: Input buffer size is set to 45 bytes.

From when free area decreases to 16 bytes until it increases to 26 bytes, receive buffer is full with printer BUSY status.

OFF (0) OPERATION: Input buffer size is set to 4K bytes.

From when free area decreases to 128 bytes until it increases to 256 bytes, receive buffer is full with printer BUSY status.

●**MSW1-3:** Busy condition

[Outline] Select the condition that printer is BUSY. Automatic status send function also runs.

	<b>OFF(0)</b>	<b>ON(1)</b>
Busy Condition	Buffer full/Off-line	Buffer full

ON (1) OPERATION: If receive buffer is full, printer is BUSY.

Automatic status send (ASB) function is enabled.

OFF (0) OPERATION: If receive buffer is full or off-line, printer is BUSY.

Automatic status send (ASB) function is disabled.

[Additional Description]

Even if ON is selected, printer enters BUSY status when power is turned on or reset by I/F or at self test print

<b>Printer Status</b>		<b>MSW1-3 OFF</b>	<b>MSW1-3 ON</b>
Off-line	Power-up or reset used by I/F	●	●
	Self-print	●	●
	Cover open	●	-
	Paper-feed by FEED SW	●	-
	Paper-end (including print stop in PNE)	●	-
	Error generation	●	-
	Waiting during macro run by FEED SW	●	-
Buffer full	Receive buffer full	●	●

●**MSW1-4:** Receive error character

[Outline] Select handling of data detected where the serial communication detects the receive data framing error; overrun error and parity error.

	<b>OFF(0)</b>	<b>ON(1)</b>
Receive Error	Print ?	No Print

ON (1) OPERATION: Not printed as ""?"

OFF (0) OPERATION: Printed as ""?"

●**MSW1-5:** CR code

[Outline] Select the printer when receiving CR(<0D>H) code.

	<b>OFF(0)</b>	<b>ON(1)</b>
CR mode	Ignored	LF

ON (1) OPERATION:

Select the same operation with LF when receiving CR code.

Print data in print buffer and put linefeeds as specified.

OFF (0) OPERATION:

CR code may be ignored with no actions if receiving CR code.

●**MSW1-6:** Reserved [Fixed to OFF (0)]

●**MSW1-7:** DSR signal

[Outline] Printer can be reset with DSR (serial I/F-6pin) signal. Select enable/disable of reset function with this signal.

	<b>OFF(0)</b>	<b>ON(1)</b>
DSR Signal	Invalid	Valid

ON (1) OPERATION: Used as reset signal

OFF (0) OPERATION: Not used as reset signal

●**MSW1-8:** INIT signal

[Outline] Printer can be reset with INIT (serial I/F-25Pin) signal. Select enable/disable of reset function with this signal.

	<b>OFF(0)</b>	<b>ON(1)</b>
INIT Signal	Invalid	Valid

ON (1) OPERATION: Used as reset signal

OFF (0) OPERATION: Not used as reset signal



## 4.2.2 MSW2

●**MSW2-1:** Reserved [Fixed to ON(1)]

●**MSW2-2:** Auto-cutter operation

[Outline] Select auto-cutter enable/disable.

	<b>OFF(0)</b>	<b>ON(1)</b>
Auto Cutter	Invalid	Valid

ON (1) OPERATION: Auto-cutter enabled

OFF (0) OPERATION: Auto-cutter disabled

●**MSW2-3:** Buffering

[Outline] Select buffering print enable/disable.

	<b>OFF(0)</b>	<b>ON(1)</b>
Spool Print	Invalid	Valid

ON (1) OPERATION: Buffering print is enabled. Buffering print means that save a certain amount of print buffer to internal RAM for collective printing

- Save a certain amount of print buffer to internal RAM for collective printing.
- If cut command such as GS+V ESC+i ESC +m are entered, print starts even before the specified amount is reached. FF or GS+FF command In Black mark mode or label model works same way.
- Even if no cut command is entered and the entered data does not reach the specified amount, entered data to print buffer is printed after no new data comes to print buffer for certain period.

OFF (0) OPERATION: Buffering print is disabled.

●**MSW2-4:** Full Columns print

[Outline] Select the processing if print data closes to the end of line or the right of print width.

	<b>OFF(0)</b>	<b>ON(1)</b>
Full Col print	Line Feed	Wait Data

ON (1) OPERATION:

If printer receives data/command exceeding the full column, printer further waits for print data. If data exceeding the full column is a command, printer operates following the command.

OFF (0) OPERATION:

If printer receives data/command exceeding the full column, it automatically prints data in buffer followed by a line-feed.

<Example>

If the first data after exceeding the full column is a control code such as<ESC !>;

If OFF (0) is set, print data within buffer and put a line feed, or

If ON (1) is set, print no data within buffer and further wait for print data.

●**MSW2-5:** Cover close return

[Outline] Select the operating taken after printer cover is opened during printing, paper is refilled with no-paper (PE) is detected, then cover is closed to restart printing.

	<b>OFF(0)</b>	<b>ON(1)</b>
Resume aft PE	Next	Top

ON (1) OPERATION:

Restart printing from the heading of remaining data.

During printing image, bar code, vertically-doubled character or page mode, if cover open or PE is detected, then after return, restart printing from heading of the remaining data.

OFF (0) OPERATION:

Print data continued from the previous printing. During printing, if cover open or PE is detected, then after return, restart printing data immediately after an error data.

\*With BD2-2220 and PMU series, Cover Close corresponds to Head Down (Platen Close) and Cover Open to Head Up (Platen Open).

●**MSW2-6:** Paper width

[Outline] Select paper width.

	<b>OFF(0)</b>	<b>ON(1)</b>
Paper width	80mm	58mm

ON (1) OPERATION: Paper width is set 80mm

OFF (0) OPERATION: Paper width is set 58mm

●**MSW2-7:** Reserved [Fixed to OFF (0)]

●**MSW2-8:** PNE sensor

[Outline] Select paper near-end enable/disable.

	<b>OFF(0)</b>	<b>ON(1)</b>
PNE Sensor	Valid	Invalid

ON (1) OPERATION: Disable paper near-end

OFF (0) OPERATION: Enable paper near-end

### 4.2.3 MSW3

●**MSW3-1:** Auto-cutter return

[Outline] Selects the return method from cutter lock error.

	<b>OFF(0)</b>	<b>ON(1)</b>
Resum Ctr Err	Valid	Invalid

ON (1) OPERATION: Return by command.

After removing error cause, return with command <DLE ENQ n>.

OFF (0) OPERATION: Return with FEED switch.

After removing error cause, return by long pressing FEED SW (1 sec or longer).

●**MSW3-2:** Clearing Cover Open Error

[Outline] Selects the method of clearing Cover Open error.

	<b>OFF(0)</b>	<b>ON(1)</b>
Resum Open Err	Close	Command

Operation at ON (1):

When the printer detects that cover is closed and the printer receives a command <DLE+ENQ+n>, the error is cleared.

Operation at OFF (0):

When the printer detects that the cover is closed, it automatically clears the error.

\*With BD2-2220, Cover Open corresponds to Head Up (Platen Open).

●**MSW3-2:** Paper end signal output at detecting paper near end

(Only for CT-S801/CT-S851/CT-S601/CT-S651)

[Outline] Selects the Valid/Invalid of PE signal at detecting PNE

	<b>OFF(0)</b>	<b>ON(1)</b>
PE output at PNE	Valid	Invalid

OPERATION at ON (1):

When paper near end is detected, printer outputs the PE signal from parallel interface. This is same behavior of ESC c 3 n command and n=15.

OPERATION at OFF (0):

When paper near end is detected, printer does not output the PE signal from parallel interface. This is same behavior of ESC c 3 n and n=12.

●**MSW3-3:** Parallel 31 pin

[Outline] Printer can be reset by parallel I/F –31 Pin signal. Select the handling of this signal.

	<b>OFF(0)</b>	<b>ON(1)</b>
Parallel 31 pin	Valid	Invalid

ON (1) OPERATION: Used as reset signal

OFF (0) OPERATION: Not used as reset signal

●**MSW3-4:** Selecting paper

[Outline] Selects either thermal paper or black mark paper.

	<b>OFF(0)</b>	<b>ON(1)</b>
Paper Select	Thermal	Black Mark

Operation at ON (1): Sets black mark paper.

Operation at OFF (0): Sets thermal paper.

●**MSW3-5:** Column Number

[Outline] Selects column number.

	<b>OFF(0)</b>	<b>ON(1)</b>
Column Number	48/32 col	42/30 col

Operation at ON (1): Column number is set 42/30 columns

Operation at OFF (0): Column number is set 48/32 columns

●**MSW3-6:** Reserved [Fixed to OFF (0)]

●**MSW3-7:** CBM compatible mode

[Outline] Select enable/disable of CBM compatible mode.

	<b>OFF(0)</b>	<b>ON(1)</b>
CBM Mode	Invalid	Valid

ON (1) OPERATION: Enable CBM compatible mode.

Control code <ESC ~ J> becomes available.

OFF (0) OPERATION: CBM compatible mode is disabled.

●**MSW3-8:** Cover open during printing

[Outline] Select the release method of cover open error during printing.

	<b>OFF(0)</b>	<b>ON(1)</b>
Resum Open Err	Close	Command

ON (1) OPERATION: Cover open error during printing becomes a return allowed error.

Returned with command <DLE ENQ n> after cover is closed.

OFF (0) OPERATION: Cover open error during printing becomes an automatic return error.

Automatically returned from cover open error by closing the cover.

\*With BD2-2220, Cover Close corresponds to Head Down (Platen Close) and Cover Open to Head Up (Platen Open).

#### 4.2.4 MSW4

●**MSW4-1:** Automatic length measurement

[Outline] In selecting black mark paper, set the enable/disable of automatic length measurement.  
(Black mark/label support model only)

	<b>OFF(0)</b>	<b>ON(1)</b>
BM Measure	Invalid	Valid

ON (1) OPERATION: Automatic length measurement is enabled.

At power-up, measurement operation is taken.

OFF (0) OPERATION: Automatic length measurement is disabled.

Operation follows the value set by <GS I>.

●**MSW4-2:** Black mark sensor position

[Outline] Selects black mark sensor position.

	<b>OFF(0)</b>	<b>ON(1)</b>
BM sensor position	surface	back

ON (1) OPERATION: Black mark sensor detects a black mark on the printing surface.

OFF (0) OPERATION: Black mark sensor detects a black mark on the printing back.

●**MSW4-2:** Searching top of form at power on.

[Outline] Set the enabled/disabled of the function to search the top of form at power on.

	<b>OFF(0)</b>	<b>ON(1)</b>
Power on TOF	Invalid	Valid

ON (1) OPERATION: Searching top is enabled

OFF (0) OPERATION: Searching top is disenabled

\*\*This function is valid only on label models or black mark models.

\*\* This function is invalid when thermal paper is selected on MSW4-4.

●**MSW4-2:** Auto Loading (Only for PMU series)

[Outline] Set the enabled/disabled of paper auto loading function.

	<b>OFF(0)</b>	<b>ON(1)</b>
Auto Loading	Invalid	Valid

ON (1) OPERATION: Auto Loading is used.

OFF (0) OPERATION: Auto Loading is not used.

●**MSW4-3:** Paper feed & cut at dosing cover

[Outline] When cover is closed, printer feeds paper and cuts.

	<b>OFF(0)</b>	<b>ON(1)</b>
Feed & Cut at TOF	Invalid	Valid

ON (1) OPERATION: Paper feed & cut at dosing cover is enabled.

OFF (0) OPERATION: Paper feed & cut at dosing cover is disabled.

●**MSW4-4:** Paper

[Outline] Selects the type of paper used.

	<b>OFF(0)</b>	<b>ON(1)</b>
Paper	Thermal roll paper	Black mark paper/Label paper

ON (1) OPERATION: Paper used is limited to black mark paper or label paper.

OFF (0) OPERATION: Paper used is limited to thermal roll paper.

●**MSW4-4:** Base style (Only for PMU2XXX/PMU2XXXII)

[Outline] Set the base style

	<b>OFF(0)</b>	<b>ON(1)</b>
Base style	PMU2XX0/2XX2	PMU2XX1

ON (1) OPERATION: PMU2XX1 (Vertical style with front paper holding)

OFF (0) OPERATION: PMU2XX0/2XX2(Horizontal style or Vertical style with back paper holding)



●**MSW4-5:** Position detect

[Outline] Selects the method of detecting paper position.

	<b>OFF(0)</b>	<b>ON(1)</b>
Position detect	Black mark	Label

ON (1) OPERATION: Detects paper position by detecting the inter-label distance.

OFF (0) OPERATION: Detects the paper position by detecting the black mark.

\*This function is valid only with black mark specification or label specification.

\*If thermal roll paper is selected by MSW4-4, this function is invalid.

\*Black mark detection is fixed with black mark specification.

●**MSW4-5:** Mechanism mounted (Only for PMU2XXX/PMU2XXXII)0

[Outline] Set the mechanism mounted on the printer

	<b>OFF(0)</b>	<b>ON(1)</b>
Mechanism mounted	LT-23XX	LT-22XX

ON (1) OPERATION: LT-22XX (2 inch mechanism)

OFF (0) OPERATION: LT-23XX (3 inch mechanism)

●**MSW4-6:** Paper Change

[Outline] On label models or black mark models, auto length measurement can be performed at cover close for using different paper. This memory switch sets this function enabled or disabled.

	<b>OFF(0)</b>	<b>ON(1)</b>
Paper Change	Invalid	Valid

ON (1) OPERATION: Auto length measurement is done at cover close.

OFF (0) OPERATION: Auto length measurement is NOT done at cover close.

●**MSW4-6:** Behavior by cover close

[Outline] Selects the behavior at closing cover for black mark or label

	<b>OFF(0)</b>	<b>ON(1)</b>
C.Close Action	Find TOF	Auto Measure

ON (1) OPERATION: Feed paper to find top of form

OFF (0) OPERATION: MSW4-1 On - Performs automatic length measurement.

MSW4-1 Off - Does not perform automatic length measurement.

●**MSW4-7:** Auto paper Select (CT-S281 unique)

[Outline] Selects Valid/Invalid of paper type auto select function.

	<b>OFF(0)</b>	<b>ON(1)</b>
Auto Paper Select	Invalid	Valid

ON (1) OPERATION: Paper type auto selection function is valid

OFF (0) OPERATION: Paper type auto selection function is invalid

\*\* Paper type auto select function determines the used paper type and sets the paper type automatically depending on the result of auto length measurement or finding black mark or top of label at power on/cover close,

\*\* Valid only if Black mark/Label is selected at MSW4-4

\*\* If MSW4-1 is set for auto length measurement or MSW4-2 is set to find TOF, this function works at power on.

\*\* If the printer is turned off with receipt mode set by this function, the printer goes back to label mode.

●**MSW4-7:** DC3 command function switch (CT-S280 unique)

[Outline] Select the operation taken when DC3 command is received.

	<b>OFF(0)</b>	<b>ON(1)</b>
DC3 command function	2 color printing	B/W reverse

ON(1) OPERATION: When DC3 command is received, black/white reverse printing mode is set / cleared.

OFF(0) OPERATION: When DC3 command is received, 2 color printing mode is set / cleared.

●**MSW4-8:** Forcible partial cut

[Outline] Select the operation taken when full cut command is received.

	<b>OFF(0)</b>	<b>ON(1)</b>
Partial only	Invalid	Valid

ON (1) OPERATION: When full cut command is received, partial cut, not full cut, is taken.

OFF (0) OPERATION: When full cut command is received, full cut is taken.

## 4.2.5 MSW5

### •MSW5-1: Buzzer

[Outline] Select the enable/disable of buzzer.

	<b>OFF(0)</b>	<b>ON(1)</b>
Buzzer	Valid	Invalid

ON (1) OPERATION: Disable buzzer

When an error occurs or memory switch setting is changed manually, no buzzer sounds.

OFF (0) OPERATION: Enable buzzer.

When an error occurs or memory switch setting is changed manually, the buzzer sounds.

### •MSW5-2: Basic vertical calculation pitch

[Outline] Select the basic calculation pitch in the paper feed direction.

	<b>OFF(0)</b>	<b>ON(1)</b>
Line Pitch	360	406

ON (1) OPERATION: Basic vertical calculation pitch is set to 1/406 inch.

Line-feed length is 3.75mm by default.

OFF (0) OPERATION: Basic vertical calculation pitch is set to 1/360 inch.

Line-feed length is 4.23mm by default.

### •MSW5-3: USB mode

[Outline] Select USB mode.

	<b>OFF(0)</b>	<b>ON(1)</b>
USB Mode	Virtual COM	Printer Class

ON (1) OPERATION: Operated as Printer class

OFF (0) OPERATION: Operated as virtual COM class

### •MSW5-4: Reserved [Fixed to OFF (0)]

●**MSW5-5:** Setting the power OFF notify (Only for CT-S4000)

[Outline] At power OFF, to notify the host of the printer power OFF, printer can send to host 3 byte power OFF notify status data ( 3BH 31H 00H).

Set to enable/disable for sending the power OFF notify status data.

	<b>OFF(0)</b>	<b>ON(1)</b>
Power OFF Info	Not send	Valid

ON (1) OPERATION:

Function to notify power ON is enabled, sending status to host.

OFF (0) OPERATION:

Function to notify power ON is disabled, sending no status to host.

●**MSW5-6:** High quality printing mode

[Outline] Selects the valid/invalid of high quality printing mode

In high quality printing mode, printing speed can be slower than normal mode.

	<b>OFF(0)</b>	<b>ON(1)</b>
High quality printing mode	Invalid	Valid

ON (1) OPERATION: Prints in high quality mode and less speed

OFF (0) OPERATION: Prints in normal mode and normal speed

●**MSW5-6:** Speed / Quality

[Outline] Selects the valid/invalid of high quality printing mode

In high quality printing mode, printing speed can be slower than normal mode.

	<b>OFF(0)</b>	<b>ON(1)</b>
Speed / Quality	Speed	Quality

ON (1) OPERATION: Prints in high quality mode and less speed

OFF (0) OPERATION: Prints in normal mode and normal speed

●**MSW5-6:** Auto Back Feed

[Outline] Selects the behavior of GS+FF (print and black mark/label ejection) command

	<b>OFF(0)</b>	<b>ON(1)</b>
Auto Back Feed	After Cut	Before Print

ON (1) OPERATION: After the cut, paper stay there and when printer receives next print data, the back feeding paper to top of form is done.

OFF (0) OPERATION: Back feeding to top of form is done immediately after the cut.

●**MSW5-7:** Not defined [Fixed to OFF (0)]

●**MSW5-8:** FAULT Output

[Outline] Selects the condition of FAULT output

	<b>OFF(0)</b>	<b>ON(1)</b>
FAULT Output	PE, PNE, Error	PE, Error

ON (1) OPERATION

At PE or Error, FAULT is output.

OFF (0) OPERATION:

At PE or PNE or Error, FAULT is output.

## 4.2.6 MSW6

### ●MSW6-1: Mode to use with the driver

[Outline] Selects the valid/invalid of mode to use with the driver

	<b>OFF(0)</b>	<b>ON(1)</b>
Mode to use with the driver	Invalid	Valid

ON (1) OPERATION: FAULT signal is not output in the error condition to parallel port..

ASB is valid at power on. (Same behavior as GS a n command and n = 15)

OFF (0) OPERATION: FAULT signal is output in the error condition to parallel port..

ASB is invalid at power on. (Same behavior as GS a n command and n = 0)

### ●MSW6-2: Character space mode

[Outline] Selects the valid/invalid of mode to have right space for each character

	<b>OFF(0)</b>	<b>ON(1)</b>
Character space mode	Invalid	Valid

ON (1) OPERATION: Default of right space of each character is "0".

Same behavior as ESC SP n command and parameter n = 0.

OFF (0) OPERATION: Default of right space of each character is "1".

The right vertical dot column in character composition matrix is repeated in the additional right space. In this mode, number of columns for font B and C is decreased by 1 - 4.

### ●MSW6-3: USB Power Save

[Outline] Select the valid/invalid of USB Power save mode.

	<b>OFF(0)</b>	<b>ON(1)</b>
USB Power Save	Invalid	Valid

When printer is connected to the host through USB, if PC power is turned off or USB cable is disconnected, printer enters special power save mode. This is USB Power save mode.

ON (1) OPERATION: Even the condition is satisfied, printer does not enter USB Power save mode.

OFF (0) OPERATION: When the condition is satisfied, printer enters the USB Power save mode.

## 4.2.7 MSW7

### ●MSW7-1: Baud rate

[Outline] Selects the baud rate which is serial interface communication condition.  
Enabled if DSW1-1 OFF is set [following memory switch setting] .

	Setting Value
Baud Rate	1200bps,2400bps,4800bps,9600bps,19200bps, 38400bps,57600bps,115200bps

### ●MSW7-2: Data length

[Outline] Selects the data length, which is a serial interface communication condition.  
Enabled if DSW1-1 OFF is set [following memory switch setting] .

	Setting Value
Data Length	7bits,8bits

### ●MSW7-3: Stop bit

[Outline] Selects the stop bit, which is a serial interface communication condition.  
Enabled if DSW1-1 OFF is set [following memory switch setting] .

	Setting Value
Stop Bit	1bit,2bits

### ●MSW7-4: Parity

[Outline] Selects the parity, which is a serial interface communication condition.  
Enabled if DSW1-1 OFF is set [following memory switch setting] .

	Setting Value
Parity	NONE, ODD, EVEN

### ●MSW7-5: Flow control

[Outline] Selects the flow control, which is a serial interface communication condition.  
Enabled if DSW1-1 OFF is set [following memory switch setting] .

	Setting Value
Flow Control	DTR/DSR, XON/XOFF



●**MSW7-6:** DMA control

[Outline] Selects the valid/invalid of DMA (Direct Memory Access) control.

	<b>Setting Value</b>
DMA control	Valid, Invalid

●**MSW7-7:** VCom flow control

[Outline] In MSW5-3, selects the flow control when virtual COM is set.

	<b>Setting Value</b>
VCom Protocol	PC setting, DTR/DSR, XON/XOFF

## 4.2.8 MSW8

●**MSW8-1:** Print width

[Outline] Selects the print width in dots.

	Setting Value
Print Width	832dots, 720dots, 660dots, 640dots, 576dots, 512dots, 436dots, 432dots, 420dots, 384dots, 360dots, 390dots, 546dots

●**MSW8-2:** Paper type

[Outline] Selects the paper type used.

	Setting Value
Paper Type	1 Color Normal, 1 Color BM, 1 Color Label, 2 color Normal, 2 Color BM

●**MSW8-3:** Top Margin

[Outline] Selects the top margin setting

	Setting Value
Top Margin	11mm, 3mm, 4mm, 5mm, 6mm, 7mm, 8mm, 9mm, 10mm

Select the length of top margin

Remarks: When cutting is performed at the end of printing, last printed line is fed to cutter position.

Thus top margin area where printer cannot print is generated at the top of next printing. This

function is to save the paper by feeding paper backward at the starting printing.

●**MSW8-4:** Line Gap Reduce

[Outline] Selects the line gap reduction ratio

	Setting Value
Line Gap Reduce	Invalid, 3/4, 2/3, 1/2, 1/3, 1/4, 1/5, ALL

This is the function to save the paper by reducing gap between lines which do not affect the print result too much.

Invalid: No reduction

3/4 to 1/5: Reduction ratio from original line gap setting

ALL: No gap between lines

- MSW8-5:** Reduced Char V/H  
 [Outline] Select the character compression ratio

	<b>Setting Value</b>
Reduced Char V/H	100%/100%, 75%/100%, 50%/100%, 100%/75%, 75%/75%, 50%/75%

This function is to save the paper by compressed character size. Character size compression is done by reducing dots of characters in vertical way or horizontal way.

Choice of compression is combination of vertical way (100%, 75% or 50%) and horizontal way (100% or 75%)

Print area is compressed as well together with the character size compression.

Remarks: Because the dot is reduced, quality of the print result can be lower.

- MSW8-6:** Auto Side Shift  
 [Outline] Select the maximum shifting length to the side

	<b>Setting Value</b>
Auto Side Shift	Invalid, 1dot, 2dot, 3dot, 4dot, 5dot, 6dot, 7dot

Print duty of specific heat element on the thermal head can be very high (For example: printing vertical line) In order to extend the life of such heat element, this function works to reduce its duty by shifting whole print data to the side periodically.

Invalid: This function does not work.

1dot – 7dot: Max length to shift to the side.

Remarks: The print data shifted to out of print area is not printed.

## 4.2.9 MSW9

●**MSW9-1:** Code page

[Outline] Selects the codepage.

	Setting Value
Codepage	PC437, Katakana, PC850, PC858, PC860, PC863, PC865, PC852, PC866, PC857, WindowsCode, Space page, PC864, ThaiCode18

●**MSW9-2:** International character

[Outline] Selects the international character.

	Setting Value
Int'Char Set	USA, France, Germany, UK, Denmark, Sweden, Italy, Spain, Japan, Norway, Denmark 2, Spain2, Latin America, Korea

●**MSW9-3:** Kanji

[Outline] Selects the enable/disable of Kanji.

	Setting Value
Kanji	ON, OFF

●**MSW9-4:** JIS

[Outline] Selects the kanji code system.

	Setting Value
JIS/Shift JIS	JIS, Shift JIS

●**MSW9-5:** Reserved [Fixed to OFF (0)]

●**MSW9-6:** Language for LCD message

[Outline] Selects the language of message shown on the LCD.

	Setting Value
LCD Language	English, Français, Deutsch, Italiano, Español, Japanese, Chinese

●**MSW9-7:** LCD download message

[Outline] Selects the valid/invalid of download message for LCD.

	<b>Setting Value</b>
LCD Ext. Char	Invalid, Valid

●**MSW9-8:** Auto back light off time

[Outline] Sets the time of LCD back light auto off.

	<b>Setting Value</b>
Back light auto off	Never, 30 seconds, 5 minutes

#### 4.2.10 MSW10

- MSW10-1:** Print density  
 [Outline] Selects the print density.

	Setting Value
Print Density	70%, 75%, 80%, 85%, 90%, 95%, 100%, 105%, 110%, 115%, 120%, 125%, 130%, 135%, 140%

- MSW10-2:** Print speed  
 [Outline] Selects the print speed.

	Setting Value
Print Speed	Level1, Level2, Level3, Level4, Level5, Level6, Level7, Level8, Level9

- MSW10-3:** ACK output timing  
 [Outline] Selects the ACK signal output timing in parallel interface.

	Setting Value
ACK Timing	Before Busy, Same Period, After Busy

- MSW10-4:** user NV memory capacity  
 [Outline] Selects the user NV memory capacity.

	Setting Value
NV User	1Kbytes, 64Kbytes, 128Kbytes, 192Kbytes

- MSW10-5:** NV graphics memory capacity  
 [Outline] Selects the NV graphics memory capacity.

	Setting Value
NV Graphic	0bytes, 64Kbytes, 128Kbytes, 192Kbytes, 256Kbytes, 320Kbytes, 384Kbytes

- MSW10-6:** Buzzer volume  
 [Outline] Selects the buzzer volume level

	Setting Value
Buzzer volume	Level1, Level2, Level3, Level4

Level 1 is the maximum and level 4 is the minimum.

●**MSW10-6:** Buzzer event

[Outline] Selects the events of the printer to activate the buzzer.

	<b>Setting Value</b>
Buzzer Event	All, Not by C.Open, Not by C.Open/PE

If "Not by C.Open" is selected, buzzer is not activated by opening cover.

If "Not by C.Open/PE" is selected, buzzer is not activated by opening cover or detecting paper end.

If "All" is selected, buzzer is activated by all the events for the buzzer activation.

●**MSW10-7:** Key lock

[Outline] Selects the valid/invalid of key lock function

	<b>Setting Value</b>
Key lock	Invalid, Valid

●**MSW10-8:** LCD display direction

[Outline] Selects the direction of message on the LCD.

	<b>Setting Value</b>
LCD display direction	Normal, Inverted

#### 4.2.11 MSW11

●**MSW 11-1:** Presenter

[Outline] Set the enable/disable of the Presenter Function.

	<b>OFF(0)</b>	<b>ON(1)</b>
Presenter	Invalid	Valid

ON (1) OPERATION: Presenter function is enabled and presenter works based on the setting of MSW11-2 to MSW11-5.

OFF (0) OPERATION: Presenter function is disabled and presenter does not work.

●**MSW11-2:** Retract Function

[Outline] Set the enable/disable of the Retract Function.

	<b>OFF(0)</b>	<b>ON(1)</b>
Retract Function	Invalid	Valid

ON (1) OPERATION: Retract Function is enabled.

Printer retracts the receipt either automatically in specified time from receipt ejection or immediately upon receiving GS R command. The direction (front or back) of retraction is set by MSW11-3.

OFF (0) OPERATION: Retract Function is disabled.

\*Default time for automatic retraction is 5 seconds

The time to retract receipt from receipt ejection can be set by customized value command GS ( E or GS R 1 command. The setting by GS R 1 is cleared by power off.

●**MSW11-3:** Retract Direction

[Outline] Set the direction of paper retraction when the retraction function is enabled. (MSW11-2 = ON)

	<b>OFF(0)</b>	<b>ON(1)</b>
Retract Direction	Rear	Front

ON (1) OPERATION: Paper is put out forward.

OFF (0) OPERATION: Paper is put out backward.



●**MSW 11-4:** Store and Eject

[Outline] Set the function to eject the paper after storing the paper enabled/disabled.

	<b>OFF(0)</b>	<b>ON(1)</b>
Store and Eject	Invalid	Valid

ON (1) OPERATION: When paper reaches the presenter roller, presenter does not eject the paper and when paper length reaches maximum length, presenter ejects the paper.

OFF (0) OPERATION: When paper reaches the presenter roller, presenter start ejecting the paper synchronously with paper feeding without storing the paper I the presenter.

●**MSW 11-5:** No print with paper

[Outline] Set the printing next receipt enabled/disabled for the condition that presenter sensor detects paper

	<b>OFF(0)</b>	<b>ON(1)</b>
No print with paper	Invalid	Valid

ON (1) OPERATION: While presenter sensor detects the paper, printer does not print next receipt. Then when printer detects no paper at presenter sensor, the next receipt is printed and ejected.

OFF (0) OPERATION: Even presenter sensor detects the paper, printer prints the next receipt and eject it.

●**MSW 11-6:** Min Receipt Length

[Outline] Set the minimum length of receipt for the presenter function

	<b>OFF(0)</b>	<b>ON(1)</b>
Min Receipt Length	75mm	120mm

ON (1) OPERATION: Minimum receipt length for the presenter function is 75mm

OFF (0) OPERATION: Minimum receipt length for the presenter function is 120mm

## 4.2.12 MSW12

### ●MSW 12-1: Bezel Function

[Outline] Set the bezel function enabled/disabled.

	<b>OFF(0)</b>	<b>ON(1)</b>
Bezel Function	Invalid	Valid

ON (1) OPERATION: Bezel function is enabled and it works as per the setting of MSW12-2, MSW12-5 and MSW12-6.

OFF (0) OPERATION: Bezel function is disabled.

### ●MSW12-2: LED Control

[Outline] Set Bezel LED control enabled/disabled during stand-by, printing or ejecting.

	<b>OFF(0)</b>	<b>ON(1)</b>
LED Control	Invalid	Valid

ON (1) OPERATION: Bezel LED control is enabled.

OFF (0) OPERATION: Bezel LED control is disabled.

\*Following initial settings can be changed by customize value command GS ( E.

Initial setting of bezel LED control      Standby: LED OFF

   Printing: LED ON

   Ejecting: LED Blinking

Initial setting of LED ON time at standby 0: LED ON continuously

Initial setting of LED blink ON/OFF time 5 seconds

\*Regardless of MSW11-2 setting, bezel LED can be controlled by GS R 2 command.

### ●MSW12-5: Show Error by LED

[Outline] Set error indication by bezel LED enabled/disabled.

When error occurs, bezel LED behaves same way as error LED synchronously.

	<b>OFF(0)</b>	<b>ON(1)</b>
Show Error by LED	Invalid	Valid

ON (1) OPERATION: Error indication by bezel LED is enabled.

OFF (0) OPERATION: Error indication by bezel LED is disabled.

●**MSW 12-6**: No print with paper

[Outline] Set the printing next receipt enabled/disabled for the condition that sensor at bezel detects the paper

	<b>OFF(0)</b>	<b>ON(1)</b>
No print with paper	Invalid	Valid

ON (1) OPERATION: While paper sensor at bezel detects the paper, printer does not print the next receipt. Then when the sensor detect no paper, printer print and eject next receipt..

OFF (0) OPERATION: Even paper sensor at bezel detects the paper, printer prints the next receipt and eject it.

\*This setting is effective only when bezel for cutter exit is mounted.

## 5. APPENDIX

### 5.1 Explanation on PAGE MODE

#### 5.1.1 Overview

The printer has two print modes: STANDARD and PAGE.

In STANDARD MODE, the printer prints or feeds paper each time it receives a print or paper feed command. In PAGE MODE, when the printer receives print commands and/or form feed commands, it simply forwards them to the specified print area of memory. Only when an ESC FF or FF is executed all the data mapped in the print area will then be printed in a batch.

For example, suppose you executed a print and line feed for data "ABCDEF"<LF>. In STANDARD MODE, the data "ABCDEF" is printed and paper is advanced one line. In PAGE MODE, the data "ABCDEF" is written in the specified print area of memory, and the memory location for the storage of the next print data is shifted one line.

The printer enters PAGE MODE with an ESC L, so that all commands received after that point are handled in PAGE MODE. When an ESC FF is executed, the data received until then is printed in a batch. When an FF is executed, the data received until then is printed in a batch, after which the printer returns to STANDARD MODE. An ESC S causes the printer to immediately return to STANDARD MODE; any print data, however, that has been stored in PAGE MODE is not printed. Instead it will be cleared.

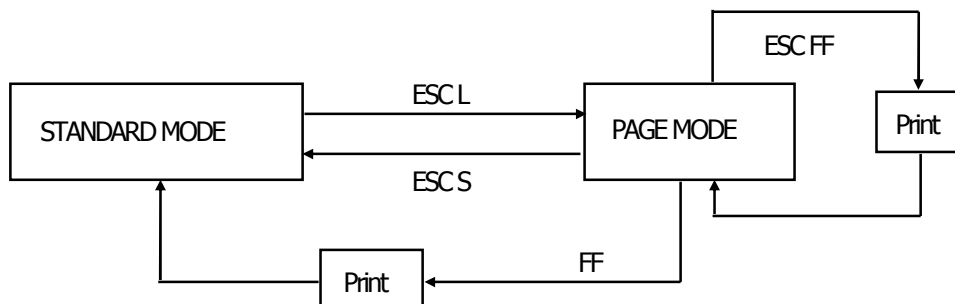

[Switching Between STANDARD MODE and PAGE MODE]

#### 5.1.2 Values Set by Each Command in STANDARD MODE and PAGE MODE

(1) The values set with commands are common to the STANDARD MODE and PAGE MODE. The values set with any of the commands listed below are, however, treated differently and stored separately for the STANDARD and PAGE MODES.

- ESC SP, ESC 2, ESC 3, FS S

(2) The maximum printable size of a bitmap image is 576 dots for STANDARD MODE. In PAGE MODE, the maximum printable size of a bitmap image is 831 dots in the "y" direction (paper feed direction). (However 831 dots are reserved for "y" of the print area set by ESC W and the value of print direction "n" specified by ESC T is 1 or 3.)

### 5.1.3 Mapping of Print Data in the Print Area

Print data is mapped in the print area as follows:

(1) The print area is set by ESC W. When the printer has finished all of the print and paper feed actions specified before receiving an ESC W, the ESC W sets the right end (as viewed facing the printer) as the start point (x0, y0) of the print area. The print area is a rectangle defined by two edges extending from the start point (x0, y0): one edge running in the "X" (Horizontal) direction by "dx" pitch (inclusive of the start point), and the other running in the "Y" (Vertical) direction by "dy" pitch. (If no ESC W is defined, the default values are used to define the print area.)

(2) With a print area defined by ESC W and a print direction specified by ESC T, when the printer receives print data, the print data is mapped in the print area where point A (see the Figure 4-1 "Mapping Position for Character Data") is used as the initial value of the start point. If the print data consists of characters, this start point serves as the baseline.

If the print data is a downloaded bitmap image or a bar code, the print data is mapped with its lower-left point B aligned to the baseline. (See the Figure 4-2 "Mapping Positions for Print Data".) When attempting to map the HRI characters of a bar code, however, the section above the standard character height will not be printed.

(3) If print data (or the space to the right of a character) extends beyond the print area before a command that involves a line feed (for example, LF or ESC J command) is received, a line feed is automatically executed in the print area, so that the mapping position of the print data is moved one line. The next mapping position will be the beginning of the line. In this case, the line feed width is as defined by a command such as ESC 2 or ESC 3.

(4) By default, the line feed width is 1/6 inch, which is equivalent to 34 dots. If the print data for the next line includes a vertically doubled or taller character, a downloaded bitmap image extending two or more lines, or a bar code taller than the character height, the data, therefore, falls short of the line feed width, causing the upper dots of the character to overlap the print data of the current line. The line feed width needs to be increased.

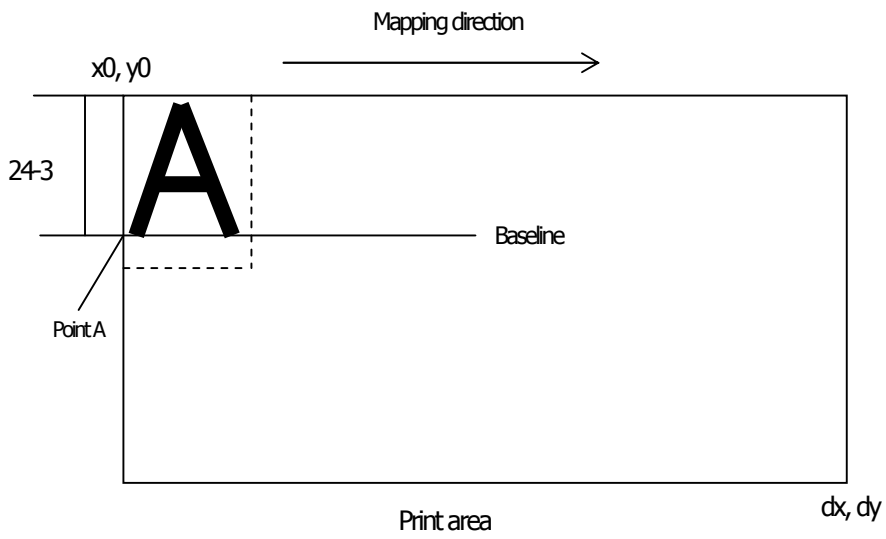

**Figure 5-1 Mapping Position for Character Data**

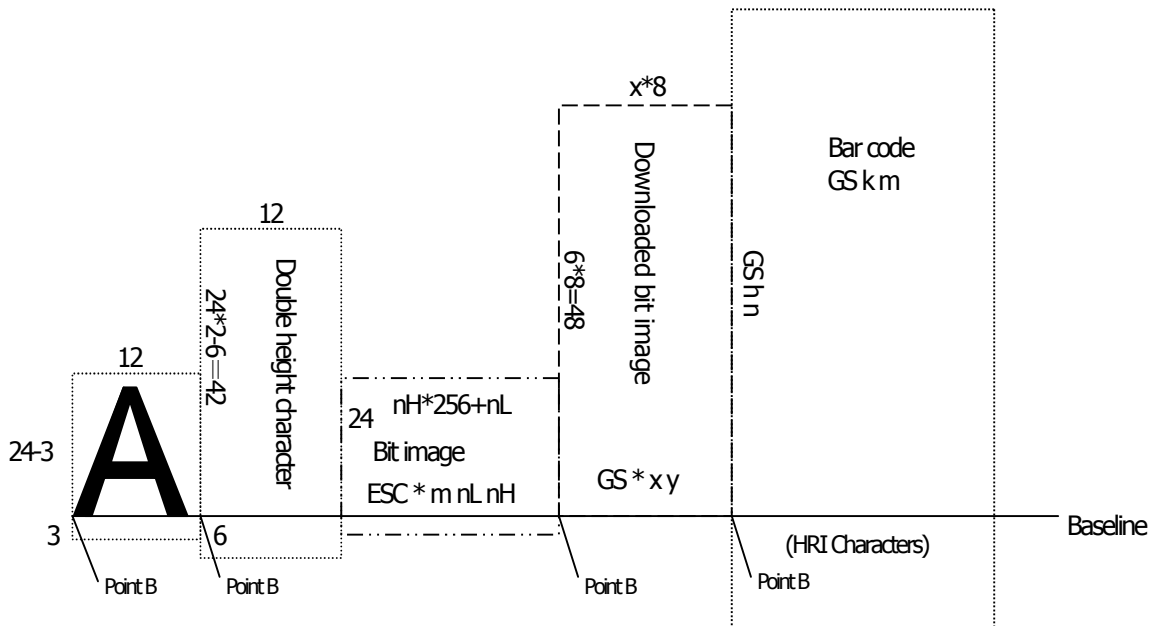

**Figure 5-2 Mapping Positions for Print Data**

### 5.1.4 Example of Using PAGE MODE

The following explains specific uses of PAGE MODE.

When in PAGE MODE, the commands are typically sent from the host to the printer in the following sequence:

- (1) An ESC L puts the printer in PAGE MODE.
- (2) An ESC W specifies the print area.
- (3) An ESC T specifies the print direction.
- (4) Print data is sent.
- (5) An FF instructs the printer to print the print data in a batch.
- (6) After printing, the printer returns to STANDARD MODE.

#### < Example 1 >

```
100 PRINT #1, CHR$(8H1B);"L";
110 PRINT #1, CHR$(8H1B);"W";CHR$(0);CHR$(0);CHR$(0);CHR$(0);
120 PRINT #1, CHR$(200);CHR$(0);CHR$(144);CHR$(1);
130 PRINT #1, CHR$(8H1B);"T";CHR$(0);
140 PRINT #1, "Page mode lesson Test1"
150 PRINT #1, CHR$(8HC);
```

The program in Example 1 reserves a print area of 200 . 400 pitches extending from the start point (0, 0), and then prints the text "Page Mode lesson Test 1" on the first line of the print area as shown in Figure 5-3 "Example 1: Results of Print".

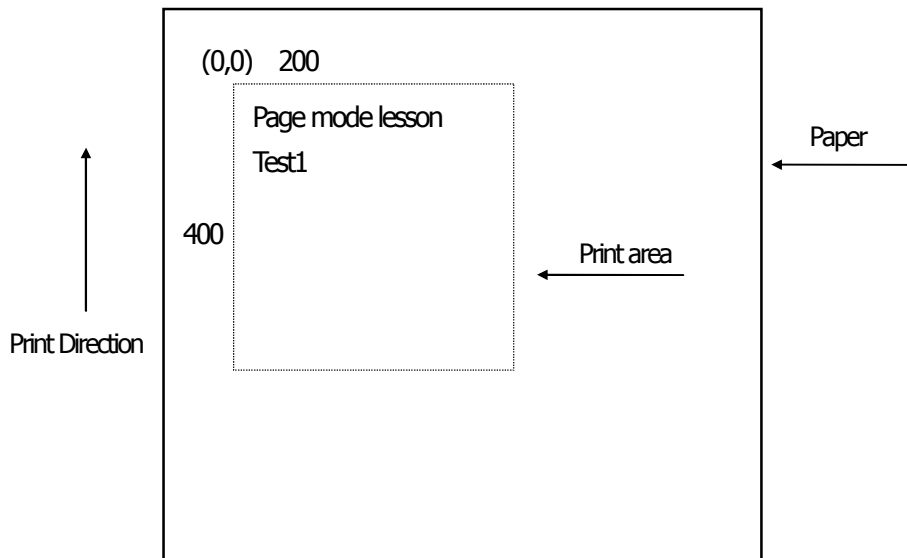

Figure 5-3 Example 1: Results of Print

In Figure 4-3, a line feed occurs between "lesson" and "Test 1" because the space " " next to "lesson" does not fit in the horizontal range of the 200, 400-pitch print area. The line feed width conforms to the value specified by a command such as ESC 3.

It is possible to set as many print areas as desired before executing FF. If print areas overlap each other, the print area setup data are ORed with the previous data.

If you want to erase a section of mapped data, use the CAN command. The CAN command erases all data in the print area being specified. You can, therefore, use an ESC W to define a print area that encloses the section you want to erase, and then execute the CAN command, so that the section of the data is erased.

It is important to remember that any part of a character that overlaps with the specified print area will be erased.

#### < Example 2 >

```
100 PRINT #1, CHR$(&H1B);"L";
110 PRINT #1, CHR$(&H1B);"W";CHR$(0);CHR$(0);CHR$(0);CHR$(0);
120 PRINT #1, CHR$(200);CHR$(0);CHR$(144);CHR$(1);
130 PRINT #1, CHR$(&H1B);"T";CHR$(0);
140 PRINT #1, "Page mode lesson2CAN command";
150 PRINT #1, CHR$(&HA);
160 PRINT #1, "ABCDEFGHJKLMNOPQRST1234567890";
170 PRINT #1, CHR$(&HC);
```

First, an ESC L is sent to switch to PAGE MODE (100th line). Next, an ESC W is used to send eight arguments, n1 to n8, to reserve a print area. In this example, the arguments are sent in the sequence of 0, 0, 0, 0, 200, 0, 144, and 1, to reserve a print area that measures 200 from the start point (0, 0) in the "X" direction and 400 in the "Y" direction (110th to 120th line). Furthermore, an ESC T is issued to specify the print direction to be "0" (130th line).

After the above setup, print data is sent (140th to 160th line). Finally, an FF is sent (170th line) to produce a print-out as shown in Figure 5-4 "Example 2: Result of Print".



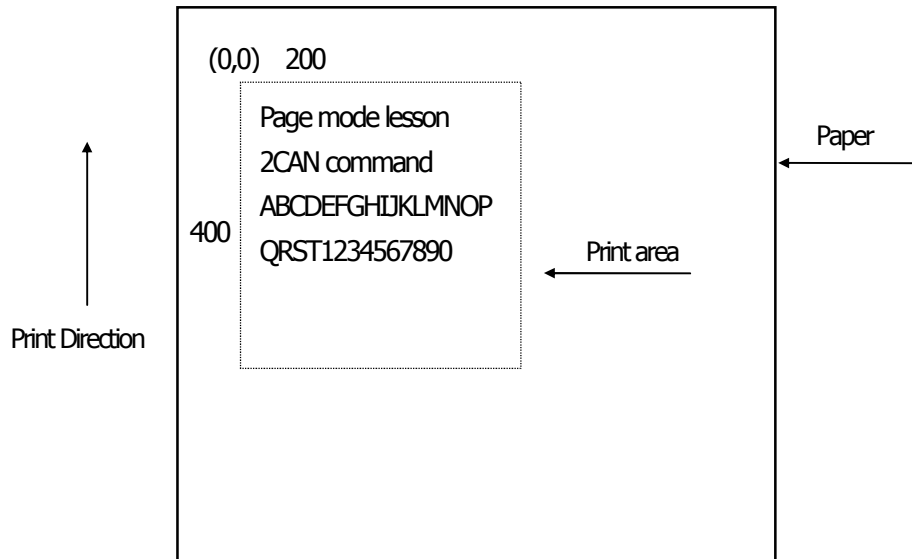

**Figure 5-4 Example 2: Result of Print**

Before an FF is sent (170th line), the following program code can be added to remove part of the data.

**< Example 2 >**

```
180 PRINT#1, CHR$(&H1B);"W";CHR$(72);CHR$(0);CHR$(120);CHR$(0);
190 PRINT#1, CHR$(36);CHR$(0);CHR$(48)CHR$(0);
200 PRINT#1, CHR$(&H18);
```

As a result of the additional program code, a print-out is executed as shown in Figure 5-5 "Print Result of Adding a Program of Example 3 to Example 2", where the string "GHI" is removed.

When strings are removed with CAN, the area where the string would have been is not used by the rest of the data, instead it is converted into a sequence of spaces.

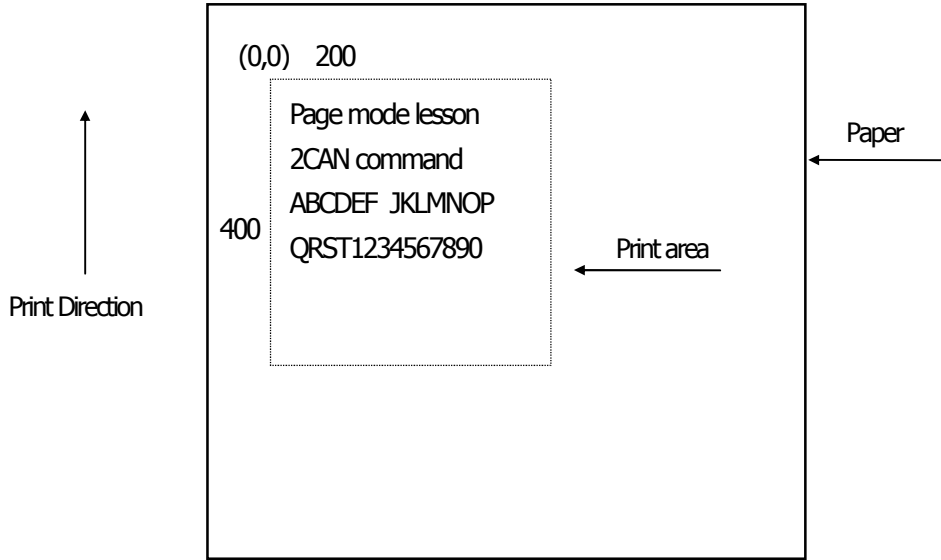

**Figure 5-5 Print Result of Adding a Program of Example 3 to Example 2**

## 5.2 Bidirectional Parallel Interface

### Overview

The interface of the printer is a Level-1 compatible device according to IEEE-P1284. It supports the communication modes described in 5.2.1 below.

### 5.2.1 Parallel Interface Communication Mode

The parallel interface of the printer provides three communication modes as outlined below. When the printer is turned on or reset, it defaults to Compatibility mode.

- Compatibility Mode

Data is transmitted from the host to the printer in units of one byte. Usually, this mode is used for data transmission. You may switch to the other modes from Compatibility mode.

- Nibble Mode

Data is transmitted from the printer to the host in units of four bits. The data transmission from the printer uses a status signal line. To send one byte of data in this mode, two sets of four-bit data are sent consecutively.

- Byte Mode

Data is transmitted from the printer to the host in units of one byte. Data transmission from the printer uses an 8-bit data signal line. For Byte mode, the host must be capable of toggling the signal direction over the 8-bit data signal line. Communication from the host to the printer is called Forward mode, while communication from the printer to the host is called Reverse mode.

\*Remarks: CT-P29x series cannot use this mode.

## 5.2.2 Interfacing Phases

Interfacing in each communication mode is divided into several phases. In addition, there is a phase for mode initialization, as well as a phase for mode switching. Interface signals may differ in name and function for different modes and different phases.

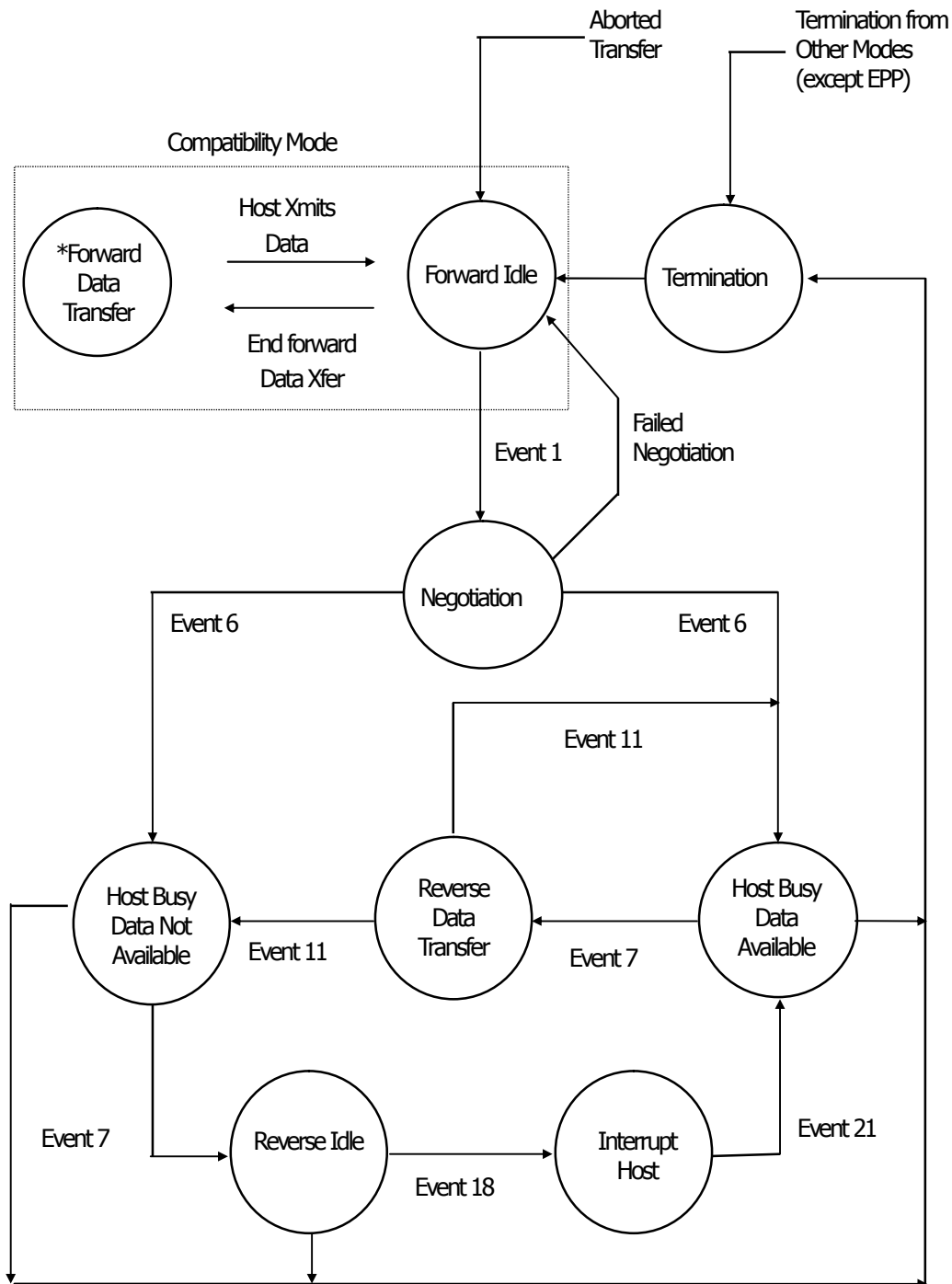

## 5.2.3 Negotiation

### Overview

Usually, the printer is started in Compatibility mode, which corresponds to the Centronics interface phase.

When the host intends to switch to the Nibble or Byte mode, it sends a request and negotiates with the printer. A general flow of negotiations is given below.

- (1) The host sets the IEEE 1284 Active signal to High. In response, the printer moves into the Negotiation phase.
- (2) The printer replies whether it can execute the mode requested by the host.
- (3) The interface terminates the Negotiation phase and moves into the communication phase.

### Negotiation Procedure

The negotiations proceed as follows:

- (1) In IEEE 1284 communication mode, the host and printer are in Compatibility mode by default. They remain in Compatibility mode as long as the host recognizes the connected device as an IEEE 1284 compatible device.
- (2) To start negotiations, the host sets the communication mode request bit on the data path. (Event 0)
- (3) The host sets IEEE 1284 Active (nSelectIn) to High, and HostBusy (nAutoFd) to Low. (Event 1)
- (4) The printer responds by setting PtrClk (nAck) to Low, nDataAvail (nFault) to High, Xflag (Select) to High, and AckDatReq (PError) to High. (Event 2)
- (5) The host sets HostClk (nStrobe) to Low. In response, the printer latches the data of the communication mode request bit. (Event 3)
- (6) The host sets HostClk (nStrobe) and HostBusy (nAutoFd) to High. (Event 4)
- (7) If the printer has communication data to send to the host, it sets AckDataReq (PError) to Low, nDataAvail (nFault) to Low, and Xflag (Select) to the value corresponding to the communication mode. (Event 5)  
Xflag: Nibble Mode : Low  
Byte Mode : High
- (8) The printer sets PtrClk (nAck) to High to indicate that it is ready to read status lines. (Event 6)
- (9) If the printer has communication data to send to the host, the host moves into the Host Busy Available phase or Termination phase, and then returns to the Compatibility mode.
- (10) If the printer has no communication data to send to the host, the host moves into the Host Busy Data Not Available phase or Termination phase, and then returns to the Compatibility mode.
- (11) If the printer cannot support the communication mode requested by the host, it sets Xflag (Select) as follows:  
When Nibble mode is requested : High  
When Byte mode is requested : Low

## Precautions

- (1) The Negotiation phase is triggered when the IEEE 1284 Active signal sent by the host becomes High.
- (2) In Compatibility mode, the time when the negotiation process begins is, as a general rule, after the host sets nStrobe to High and then the printer outputs an nAck pulse.  
Once the nStrobe signal is set to High, however, the printer immediately moves into the Negotiation phase when the high state of IEEE 1284 Active is detected, even if the nAck pulse has yet to be output or is being output. In this case, if the printer has returned to Compatibility mode after Termination, no nAck pulse will be output.
- (3) Negotiations can be entered from the Busy or Error state of the Compatibility mode. In this case, the printer will not return to the Busy or Error state before the negotiations, but still remains in the printer state just after Termination.
- (4) If the host requested a communication mode that is not supported by the printer, it must move into the Termination phase and return to the Compatibility mode.

**Table Definitions of Request Bits in IEEE 1284 Communication Mode**

bit	Definition	Bit Values (76543210)	Hex Code	Xflag	
				When Supported	In the Printer
7	Request Extensibility Link	10000000	80H	High	Low
6	Request EPP Mode	01000000	40H	High	Low
5	Request ECP Mode with RLE	00110000	30H	High	Low
4	Request ECP Mode	00010000	10H	High	Low
3	Reserve	00001000	08H	High	Low
2	Request Device ID:Return Data Using Nibble Mode	00000100	04H	High	High
	Byte Mode Rev Channel Transfer	00000101	05H	High	High
	ECP Mode Transfer without RLE	00010100	14H	High	Low
	ECP Mode Transfer with RLE	00110100	34H	High	Low
1	Reserve	00000010	02H	High	Low
0	Byte Mode Reverse Channel Transfer	00000001	01H	High	High
non	Nibble Mode Reverse Channel Transfer	00000000	00H	Low	Low
	Illegal or Contradictory Request	Other than above	Other than above	—	Low

The printer only supports the Nibble and Byte modes. For a request for any other mode, Xflag is set to Low.

\*Remarks: CT-P29x series support Nibble Mode only.

## Data Communication from Printer to Host

### Nibble Mode

In this mode, data is transferred between the printer and the host through the procedure described below.

The steps beginning from (1) are applicable when the Negotiation phase has switched to the Host Busy Data Available phase. If the Negotiation phase has switched to the Host Busy Data Not Available phase, the procedure starts at step (9).

- (1) After the negotiations for the entry into Nibble mode are completed, the host sets HostBusy (nAutoFd) to Low to indicate that it is ready to receive data from the printer. (Event 7)
- (2) The printer places the low-order four bits on the reverse channel data line and sets PtrClk (nAck) to Low. (Events 8 and 9)
- (3) The host sets HostBusy (nAutoFd) to High to indicate that it has latched data and received the signal in Event 9. (Event 10)
- (4) The printer sets PtrClk (nAck) to High. This completes transfer of the first nibble. (Event 11)
- (5) Steps (1) to (3) are repeated to transfer the high-order four bits, before proceeding to steps (6) and on.
- (6) After the host has set HostBusy (nAutoFd) to High (Event 10) and received data, the printer must set the four status lines as shown below. (Event 13)
  - PtrBusy (Busy) : Returned to the status given in Forward mode.
  - nDataAvail (nFault) : Set to Low if there is data to be sent.
  - AckDataReq (PError) : Set to Low if there is data to be sent.
  - Xflag (Select) : Set to the current mode (i.e., set to Low).
- (7) The printer sets PtrClk (nAck) to High. (Event 11)
- (8) After Event 11, the host checks the signals set by the printer in Event 13. With this check the host determines:
  1. Whether there is more data to be sent from the printer to the host;
  2. And whether data can be transferred from the host to the printer.
- (9) If there is no more data to be sent from the printer after the transfer of one byte (two nibbles), the host chooses one of three status selections:
  1. Performing Termination and returning to the Compatibility mode.
  2. Remaining in the Host Busy Data Not Available phase.
  3. Setting HostBusy (nAutoFd) to Low (Event 7) and moving to the Reverse Idle phase.
- (10) If there is more data to be received from the printer, the host chooses one of three status selections:
  1. Setting HostBusy (nAutoFd) to Low and indicating that the host is ready to receive.
  2. Remaining in the Host Busy Data Available phase.
  3. Performing Termination and returning to the Compatibility mode.
- (11) If the host selected the Host Busy Data Available phase and set HostBusy (nAutoFd) to Low, the printer repeats the steps from (2) onwards.
- (12) If the host selected the Reverse Idle phase and new data becomes available to be sent from the printer, the printer sets PtrClk to Low to request the host for an interrupt. (Event 18)
- (13) The printer sets PtrClk back to High. (Event 19)

- (14) Upon receiving a request for interrupt from the printer, the host responds by setting HostBusy (nAutoFd) to High. (Event 20)
- (15) Finally, the printer responds to the host by setting AckDataReq (PError) to Low, and then the host moves to the Host Busy Data Available phase. (Event 21)



## Byte Mode

In this mode, data is transferred between the printer and the host through the procedure described below.

The steps beginning from (1) are applicable when the Negotiation phase has switched to the Host Busy Data Available phase. If the Negotiation phase has switched to the Host Busy Data Not Available phase, the procedure starts at step (9).

- (1) After the negotiations for the entry into the Byte mode are complete, the host indicates that it is ready to receive data from the printer. This is indicated by switching the data bus to a high-impedance state and setting HostBusy (nAutoFd) to Low. (Events 14 and 7)
- (2) The printer places communication data on the data bus. (Event 15)
- (3) The printer sets PtrClk (nAck) to Low. (Event 9)
- (4) The host sets HostBusy (nAutoFd) to High to indicate that it has latched data and received the signal in Event 9. (Event 10)
- (5) The printer must set the four status lines as shown below. (Event 13)
  - PtrBusy (Busy): Returned to the status given in the Forward mode.
  - nDataAvail (nFault): Set to Low if there is data to be sent.
  - AckDataReq (PError): Set to Low if there is data to be sent.
  - Xflag (Select): Set to the status given during the last negotiation (i.e., set to Low).
- (6) The printer sets PtrClk (nAck) to High (Event 10) and ends the Byte handshake. (Event 11)
- (7) The host indicates that it has succeeded in receiving the data. This is indicated by setting HostClk (nStrobe) to Low (Event 16) and then to High. (Event 17)
- (8) Events 10 and 16 may occur simultaneously, and Events 7 and 17 may occur simultaneously. (Such as when HostBusy and HostClk are used together.)
- (9) After transferring one byte of data, the printer signals to the host whether it has more data to transfer. When there is no more data to be received by the host from the printer, the host chooses one of three status selections:
  1. Performing Termination and returning to the Compatibility mode.
  2. Remaining in the Host Busy Data Not Available phase.
  3. Setting HostBusy (nAutoFd) to Low and moving to the Reverse Idle phase. (Event 7)
- (10) When more data is to be received from the printer, the host chooses one of three status selections:
  1. Setting HostBusy (nAutoFd) to Low and indicating that the host is ready to receive.
  2. Remaining in the Host Busy Data Available phase.
  3. Performing Termination and returning to the Compatibility mode.

## Device ID

The device ID is a character string that provides the ID, the type, and other information regarding the printer connected to the interface. When the printer receives a request for a device ID from the host, it replies with the following device ID:

```
<00>H<2E>H  
MFG:CITIZEN;  
CMD:ESC/POS;  
MDL:CT-S300;(*)  
CLS:PRINTER;
```

\*This value differs by model and model name is returned.

The first two bytes of the device ID indicate the length of the entire device ID. For a description of a request for a device ID, refer to the "Negotiation" section.

When the host receives the device ID string of the length indicated by the first two bytes, it must do so consecutively, without terminating the process until the entire device ID is received. If the process is terminated halfway, the printer discards the rest of the string; when the printer receives a new request for the device ID, it sends the device ID beginning from the first character of the ID. After receiving the ID of the length indicated by the first two bytes, the host must carry out the termination even if the printer has data to send (Data Available). If the host does not carry out Termination and tries to receive data, the printer sends the printer status.

## Termination

Termination is the process of returning to Compatibility mode from the Nibble or Byte modes. When performing Termination, the host sets the signals as follows:

- IEEE 1284 Active (nSelectIn): Low
- HostBusy (nAutoFd): High (Event 22)

There are two methods of Termination:

- (1) Termination through a handshake between the host and the printer
- (2) Immediate termination

(1) Termination through a handshake between the host and the printer:

When switching from Reverse mode to Compatibility mode, this termination method can be used if the interface is activated (IEEE 1284 Active: High) and Event 22 has taken place.

- 1) The printer responds to IEEE 1284 Active by setting PtrBusy (Busy) and nDataAvail (nFault) to High. (Event 23)
- 2) The printer then inverts Xflag (Select) and sets PtrClk (nAck) to Low. (Event 24)
- 3) The host sets HostBusy (nAutoFd) to Low. (Event 25)
- 4) The printer returns nDataAvail (nFault), Xflag (Select), and AckDataReq (PError) to the status given in the Compatibility mode, and sets PtrClk (nAck) to High. (Events 26 and 27)
- 5) The host sets HostBusy (nAutoFd) to High to terminate the handshake and return the interface to the Compatibility Mode Idle phase. (Event 28)
- 6) The printer changes PtrBusy (Busy) to be able to receive data from the host.

(2) Immediate termination:

- 1) If the interface is deactivated (IEEE 1284 Active: Low) without Event 22 having taken place, the printer immediately performs Termination. In this termination, the data is not guaranteed, and the printer switches the data bus from output to input within 1  $\mu$ sec.

In the Reverse Idle phase, the printer can notify the host that it has data to transfer to the host. The notification may occur simultaneously with termination in order for the host to move from the Idle phase to the Compatibility mode.

If the printer has data to send, it initiates the Interrupt phase indicated by Events 8 and 9. In this case, if 1284 - Active (nSelectIn) was set to Low before HostBusy (nAutoFd) changed from High to Low, the printer interprets that the host has switched to the Termination phase, and then completes the normal termination through handshaking.

### 5.3 Identification of Send Status

Because the status sent from the printer has certain fixed bits, it is possible to identify to which command the status belongs.

When using ASB (Automatic Status Back), however, the first byte of ASB should be checked, and then the three consecutive bytes except for XOFF should be treated as ASB data.

#### Identification of Send Status

Command and Function	Status
GS I	<0**0****>B
GS r	<0**0****>B
XON	<00010001>B
XOFF	<00010011>B
DLE EOT	<0**1**10>B
ASB (1st byte)	<0**1**00>B
ASB (2nd - 4th bytes)	<0**0****>B

## 5.4 Cautions on Black Mark/Label Paper

Cautions on LF (CR), ESC J, ESC d, Page mode, Image, and barcode printing.

Printing of image greater than vertical print area of BM paper/label paper used is prohibited as a rule.

The user must use label while taking label size into account at all times and terminate printing of a sheet of label with FF, ESC FF or GS FF.

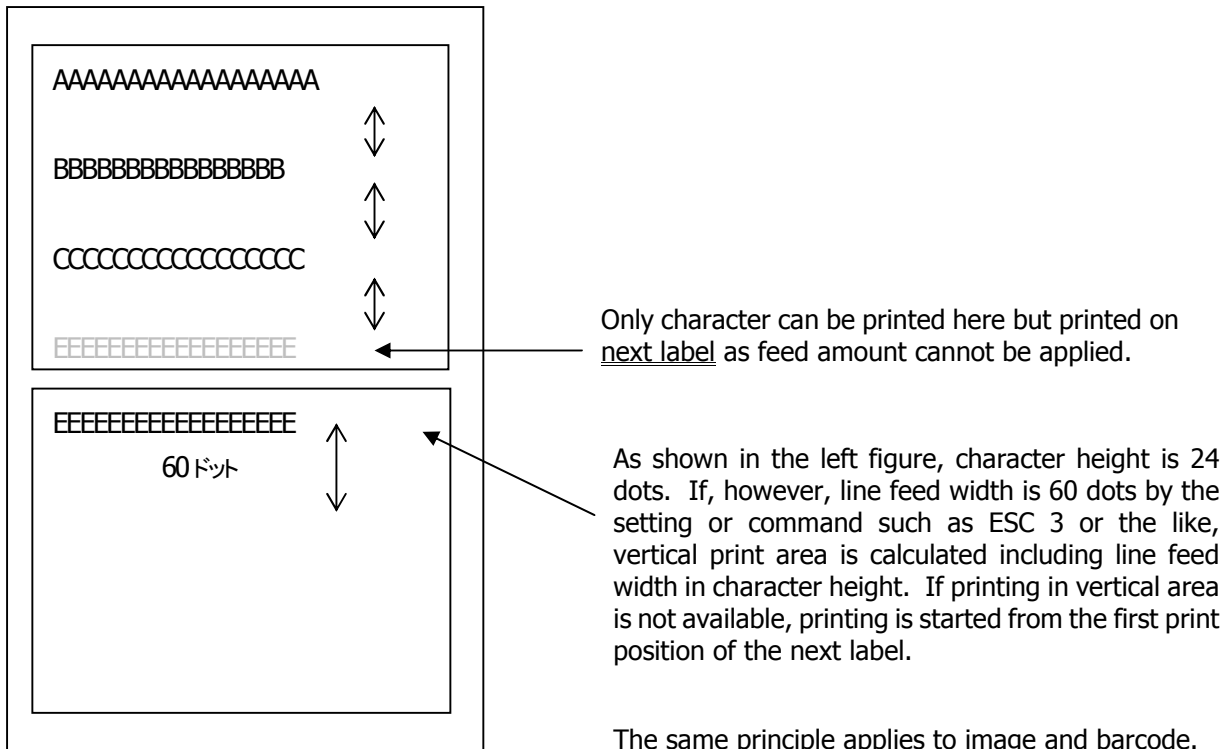
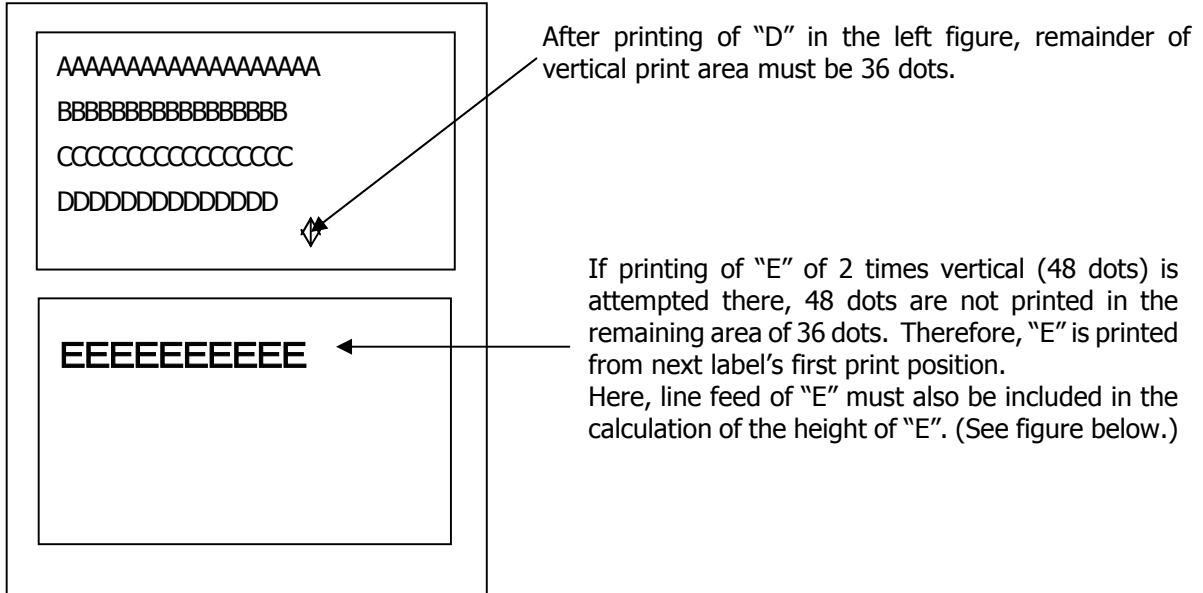

The same principle applies to image and barcode. Barcode and image are as shown on the next page.

If printing of image greater than inter-BM distance/label paper length (vertical print area width) is attempted, image is printed in two separated images as shown below.

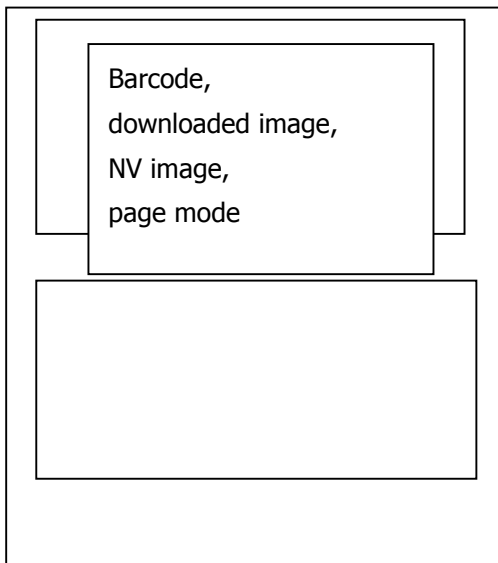
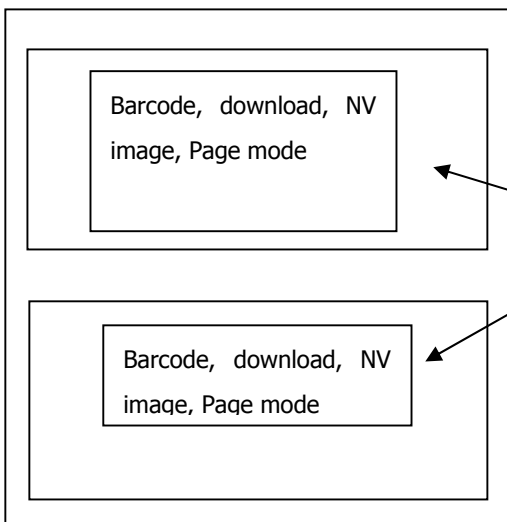

Image greater than vertical print area of label paper used is printed over the label. In this case, head and bottom margins must be taken into account.



Printing occurs in two or more separate areas.